



Automotive
Energy & Power Analysis
Aerospace & Defense
Transportation
General Test & Measurement

DEWE-50-USB2-8

Technical reference manual



Re-inventing Data Acquisition



Copyright © DEWETRON elektronische Messgeraete Ges.m.b.H.

This document contains information which is protected by copyright. All rights are reserved. Reproduction, adaptation, or translation without prior written permission is prohibited, except as allowed under the copyright laws.

All trademarks and registered trademarks are acknowledged to be the property of their owners.

Thank you!

Thank you very much for your investment in DEWETRON's unique data acquisition systems. These are top-quality instruments which are designed to provide you years of reliable service. This guide has been prepared to help you get the most from your investment, starting from the day you take it out of the box, and extending for years into the future.

This guide includes important startup notes, as well as safety notes and information about keeping your DEWETRON system in good working condition over time.

We strongly suggest that you read this entire manual, especially the safety and care sections, as well as to avoid damaging your DEWETRON system.

What is the DEWE-50-USB2-8?

This product is used for measuring of different physical and/or electrical sizes (depending on model or configuration). The connection is depending on model or configuration and takes place via safety banana plugs, BNC connectors ($\pm 50V$ max.), D-SUB connectors ($\pm 50V$ max.), thermocouple connectors ($\pm 50V$ max.), BINDER® connectors ($\pm 50V$ max.) or LEMO® connectors.

Preface

Notes

Content

General Information, Safety Instructions	7
Training	7
Calibration.....	7
Support	7
Service/repairs	7
Warranty Information	8
Printing History.....	8
Safety symbols in the manual	9
General safety and hazard warnings for all DEWETRON systems	10
Windows updates and antivirus/security software	13
Problematic network stacks	13
Environmental Considerations	13
Blockdiagram of the internal signal processing	14
First steps	15
Main System	17
DEWE-50-USB2-8 - USB solution for your computer	17
System specifications	17
DEWE-50-USB2-8 at a glance	18
Synchronizing two DEWE-50-USB2-8 systems	20
DAQP series amplifiers overview	21
Power supply	23
DEWE-50-USB2-8 installation guide	24
DEWESoft configuration.....	25
CAN setup	26
Maintenance.....	26
Software	27
Internal Wiring	B1
CE-Certificate of conformity	C1

Table of content

Training

DEWETRON offers training at various offices around the world several times each year. DEWETRON headquarters in Austria have a very large and professional conference and seminar center, where training classes are conducted on a regular basis starting with sensors and signal conditioning, A/D technology and software operation. For more information about training services, please visit:
<http://www.dewetron.com/support/training>

Dewetron Inc. in the USA also has a dedicated training facility connected to its headquarters, located in Rhode Island. For more information about training services in the US, please visit:
<http://www.dewamerica.com/support/training>

Calibration

Every instrument needs to be calibrated at regular intervals. The standard norm across nearly every industry is annual calibration. Before your DEWETRON data acquisition system is delivered, it is calibrated at our DEWETRON headquarter. Each of this system is delivered with a certificate of compliance with our published specifications. Detailed calibration reports from our calibration system are available for purchase with each order. We retain them for at least one year, so calibration reports can be purchased for up to one year after your system was delivered.

Support

DEWETRON has a team of people ready to assist you if you have any questions or any technical difficulties regarding the system. For any support please contact your local distributor first or DEWETRON directly.

For Asia and Europe, please contact:

DEWETRON Ges.m.b.H.
Parkring 4
A-8074 Graz-Grambach
AUSTRIA
Tel.: +43 316 3070
Fax: +43 316 307090
Email: support@dewetron.com
Web: <http://www.dewetron.com>

The telephone hotline is available
Monday to Friday between
08:00 and 17:00 CET (GMT +1:00)

Service/repairs

The Team of DEWETRON also performs any kinds of repairs to your system to assure a safe and proper operation in future. For information regarding service and repairs please contact your local distributor first or DEWETRON directly.

For the Americas, please contact:

DEWETRON, Inc.
10 High Street, Suite K
Wakefield, RI 02879
U.S.A.
Tel.: +1 401 284 3750
Toll-free: +1 877 431 5166
Fax: +1 401 284 3755
Email: support@dewamerica.com
Web: <http://www.dewamerica.com>

The telephone hotline is available
Monday to Friday between
08:00 and 17:00 GST (GMT -5:00)

Notice

The information contained in this document is subject to change without notice.

DEWETRON elektronische Messgeraete Ges.m.b.H. (DEWETRON) shall not be liable for any errors contained in this document. DEWETRON MAKES NO WARRANTIES OF ANY KIND WITH REGARD TO THIS DOCUMENT, WHETHER EXPRESS OR IMPLIED. DEWETRON SPECIFICALLY DISCLAIMS THE IMPLIED WARRANTIES OF MERCHANTABILITY AND FITNESS FOR A PARTICULAR PURPOSE. DEWETRON shall not be liable for any direct, indirect, special, incidental, or consequential damages, whether based on contract, tort, or any other legal theory, in connection with the furnishing of this document or the use of the information in this document.

Warranty Information

A copy of the specific warranty terms applicable to your DEWETRON product and replacement parts can be obtained from your local sales and service office.

Restricted Rights Legend

Use austrian law for duplication or disclosure.

DEWETRON GesmbH
Parkring 4
A-8074 Graz-Grambach / Austria

Printing History

Please refer to the page bottom for printing version.

Copyright © DEWETRON elektronische Messgeraete Ges.m.b.H.

This document contains information which is protected by copyright. All rights are reserved. Reproduction, adaptation, or translation without prior written permission is prohibited, except as allowed under the copyright laws.

All trademarks and registered trademarks are acknowledged to be the property of their owners.

Safety instructions

Safety symbols in the manual



Indicates hazardous voltages.

WARNING *Calls attention to a procedure, practice, or condition that could cause bodily injury or death.*

CAUTION *Calls attention to a procedure, practice, or condition that could possibly cause damage to equipment or permanent loss of data.*

WARNINGS

The following general safety precautions must be observed during all phases of operation, service, and repair of this product. Failure to comply with these precautions or with specific warnings elsewhere in this manual violates safety standards of design, manufacture, and intended use of the product. DEWETRON Elektronische Messgeraete Ges.m.b.H. assumes no liability for the customer's failure to comply with these requirements.

All accessories shown in this document are available as option and will not be shipped as standard parts.



*For safety reasons max. 50 V may be applied to the BNC input-connectors!
Refer to the regulation of maximum allowable touch potential.*

Safety instructions

Your safety is our primary concern! Please be safe!

General safety and hazard warnings for all DEWETRON systems

- Use this system under the terms of the specifications only to avoid any possible danger.
- Maintenance will be executed by qualified staff only.
- During the use of the system, it might be possible to access another parts of a more comprehensive system. Please read and follow the safety instructions provided in the manuals of all other components regarding warning and security advices for using the system.
- With this product, only use the power cable delivered or defined for the host country.
- DO NOT connect or disconnect sensors, probes or test leads, as these parts are connected to a voltage supply unit.
- The system is grounded via a protective conductor in the power supply cord. To avoid electric shocks, the protective conductor has to be connected with the ground of the power network. Before connecting the input or output connectors of the system, make sure that there is a proper grounding to guarantee potential free usage. For countries, in which there is no proper grounding, please refer to your local legally safety regulations for safety use.

DC systems: Every DC system has a grounding connected to the chassis (yellow/green safety banana plug).

- Please note the characteristics and indicators on the system to avoid fire or electric shocks. Before connecting the system, please carefully read the corresponding specifications in the product manual.
- The inputs are not, unless otherwise noted (CATx identification), for connecting to the main circuit of category II, III and IV.
- The power cord separates the system from the power supply. Do not block the power cord, since it has to be accessible for the users.
- DO NOT use the system if equipment covers or shields are removed.
- If you assume the system is damaged, get it examined by authorised personnel only.
- Any use in wet rooms, outdoors or in adverse environmental condition is not allowed!
Adverse environmental conditions are:
 - Moisture or high humidity
 - Dust, flammable gases, fumes or dissolver
 - Thunderstorm or thunderstorm conditions (except assembly PNA)
 - Electrostatic fields, et cetera.
- The measurement category can be adjusted depending on module configuration.
- Any direct voltage output is protected with a fuse against short cut and reverse-polarity, but is NOT galvanically isolated (except it is explicit marked on the system).
- The system must be connected and operated to an earthed wall socket at the AC mains power supply only (except for DC systems).
- Any other use than described above may damage your system and is attended with dangers like shortcut, fire or electric shocks.
- The whole system must not be changed, rebuilt or opened (except for changing DAQ, DAQP, PAD modules).

Safety instructions

- If you assume a more riskless use is not provided anymore, the system has to be rendered inoperative and should be protected against inadvertent operation. It is assumed that a more riskless operation is not possible anymore, if
 - the system is damaged obviously or causes strange noises.
 - the system does not work anymore.
 - the system has been exposed to long storage in adverse environmental.
 - the system has been exposed to heavy shipment strain.
 - DO NOT touch any exposed connectors or components if they are live wired. The use of metal bare wires is not allowed. There is a risk of short cut and fire hazard!
 - Warranty void if damages caused by disregarding this manual. For consequential damages NO liability will be assumed!
 - Warranty void if damages to property or persons caused by improper use or disregarding the safety instructions.
 - Unauthorized changing or rebuilding the system is prohibited due to safety and permission reasons (CE). Exception: changing modules like DAQ, DAQP or PAD.
 - The assembly of the system is equivalent to protection class I. For power supply, only the correct power socket of the public power supply must be used, except the system is DC powered.
 - Be careful with voltages >25 VAC or >35 VDC! These voltages are already high enough in order to get a perilous electric shock by touching the wiring.
 - The product heats during operation. Make sure there is adequate ventilation. Ventilation slots must not be covered!
 - Only fuses of the specified type and nominal current may be used. The use of patched fuses is prohibited.
 - Prevent using metal bare wires! Risk of short cut and fire hazard!
 - DO NOT use the system before, during or shortly after a thunderstorm (risk of lightning and high energy overvoltage). An advanced range of application under certain conditions is allowed with therefore designed products only. For details please refer to the specifications.
 - Make sure that your hands, shoes, clothes, the floor, the system or measuring leads, integrated circuits and so on, are dry.
 - DO NOT use the system in rooms with flammable gases, fumes or dust or in adverse environmental conditions.
 - Avoid operation in the immediate vicinity of:
 - high magnetic or electromagnetic fields
 - transmitting antennas or high-frequency generators
- For exact values please refer to enclosed specifications.
- Use measurement leads or measurement accessories aligned to the specification of the system only. Fire hazard in case of overload!
 - Do not switch on the system after transporting it from a cold into a warm room and vice versa. The thereby created condensation may damage your system. Acclimatise the system unpowered to room temperature.
 - Do not disassemble the system! There is a high risk of getting a perilous electric shock. Capacitors still might be charged, even the system has been removed from the power supply.
 - The electrical installations and equipments in industrial facilities must be observed by the security regulations and insurance institutions.

Safety instructions

- The use of the measuring system in schools and other training facilities must be observed by skilled personnel.
- The measuring systems are not designed for use at humans and animals.
- Please contact a professional if you have doubts about the method of operation, safety or the connection of the system.
- Please be careful with the product. Shocks, hits and dropping it from already lower level may damage your system. For exact values please refer to enclosed specifications.
- Please also consider the detailed technical reference manual as well as the security advices of the connected systems.

This product has left the factory in safety-related flawless and proper condition.

In order to maintain this condition and guarantee safety use, the user has to consider the security advices and warnings in this manual.

EN 61326-3-1:2008

IEC 61326-1 applies to this part of IEC 61326 but is limited to systems and equipment for industrial applications intended to perform safety functions as defined in IEC 61508 with SIL 1-3.

The electromagnetic environments encompassed by this product family standard are industrial, both indoor and outdoor, as described for industrial locations in IEC 61000-6-2 or defined in 3.7 of IEC 61326-1. Equipment and systems intended for use in other electromagnetic environments, for example, in the process industry or in environments with potentially explosive atmospheres, are excluded from the scope of this product family standard, IEC 61326-3-1.

Devices and systems according to IEC 61508 or IEC 61511 which are considered as “operationally well-tried”, are excluded from the scope of IEC 61326-3-1.

Fire-alarm and safety-alarm systems, intended for protection of buildings, are excluded from the scope of IEC 61326-3-1.

CAUTION

- The system BIOS is protected by password. Any change in the BIOS may cause a system crash. When the system is booting, do not press ESC-button on keyboard. This may clear the BIOS settings and cause system faults.
- Any change in the file structure as deleting or adding files or directories might cause a system crash.
- Before installing software updates contact DEWETRON or your local distributor. Use only software packages which are released by DEWETRON. Further informations are also available in the internet (<http://www.dewetron.com>).
- After power off the system wait at least 10 seconds before switching the system on again. Otherwise the system may not boot correct. This prolongs also the life of all system components.

Windows updates and antivirus/security software

Before installing Windows software updates consult with DEWETRON for compatibility guidance. Please also keep in mind that the use of any antivirus or other security software may slow down your system and may cause data loss.

Problematic network stacks

Often intrusive IT software or network processes can interfere with the primary function of the DEWETRON system: to record data. Therefore we recommend strongly against the installation of IT/MIS software and running their processes on any DEWETRON data acquisition system, and cannot guarantee the performance of our systems if they are so configured.



Environmental Considerations

Information about the environmental impact of the product.

Product End-of-Life Handling

Observe the following guidelines when recycling a DEWETRON system:



System and Components Recycling

Production of these components required the extraction and use of natural resources. The substances contained in the system could be harmful to your health and to the environment if the system is improperly handled at its end of life! Please recycle this product in an appropriate way to avoid an unnecessary pollution of the environment and to keep natural resources.

This symbol indicates that this system complies with the European Union's requirements according to Directive 2002/96/EC on waste electrical and electronic equipment (WEEE). Please find further informations about recycling on the DEWETRON web site www.dewetron.com

Restriction of Hazardous Substances

This product has been classified as Monitoring and Control equipment, and is outside the scope of the 2002/95/EC RoHS Directive. This product is known to contain lead.

Signal processing

Blockdiagram of the internal signal processing

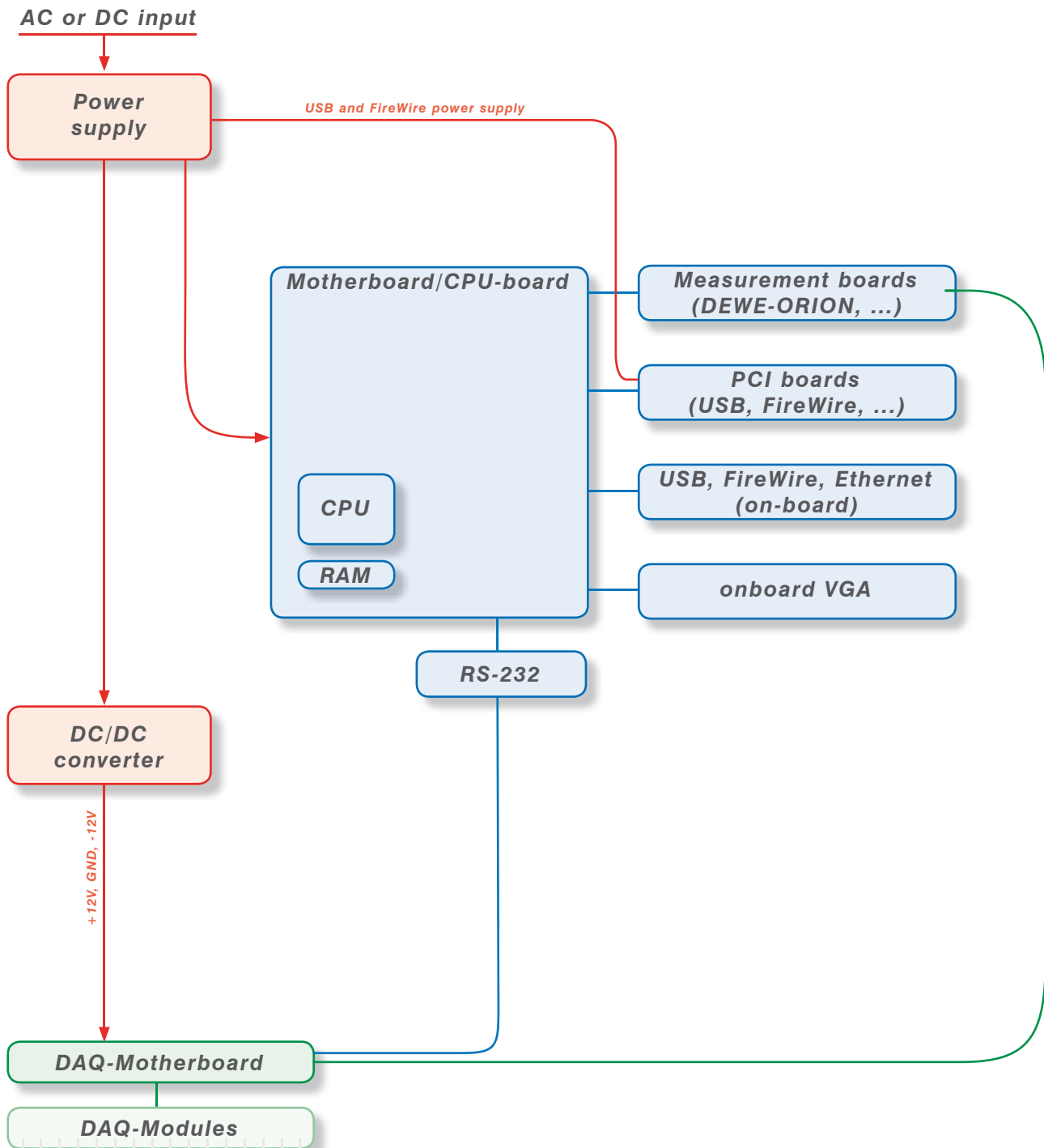

First steps

1



Power-on your system.

2

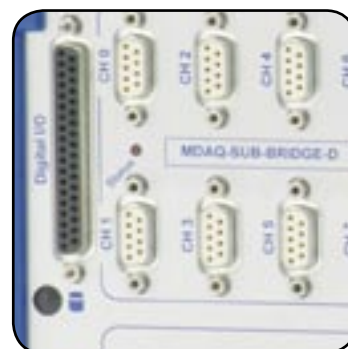

Connect your sensors to the system.

3



Run DEWESoft usually via "Start" > "Programs" > "Dewetron" > "DEWESoft x.x" > "DEWESoft x.x"

4



Start recording your data!

First steps

Notes

DEWE-50-USB2-8 - USB solution for your computer

- Prepared for up to 8 DAQ or PAD modules
- 24-bit resolution, 204.8 kS/s sampling rate per channel
- 2 counters or 6 digital inputs
- USB interface to host computer
- 2 high-speed CAN interfaces
- Optional 8 BNC sockets for the conditioned ± 5 V signal of each DAQP module



System specifications

DEWE-50-USB2-8	
Analog input	
Number of channels:	8 (simultaneously sampled)
Measured values:	According to installed DAQP modules
Internal A/D system	
Resolution:	24 bit
Type of ADC:	Delta-Sigma
Sampling rate:	204.8 kS/s
-3 dB bandwidth:	76 kHz @ 204.8 kS/s (consider possible limit of DAQP modules)
Accuracy:	± 0.05 % of range, ± 1 mV
Signal to noise @ $f_s < 1000$ Hz:	< 100 dB
Crosstalk:	< 100 dB
Power requirements	
Power supply:	10 to 36 V _{DC} (incl. external AC/DC power supply)
Typical power consumption:	Typ. 20 W (5 W internal A/D system + DAQP modules)
Counter/digital inputs	
Number of channels:	2 counters or 6 digital inputs (per software each counter can be selected to be 3x digital input)
Counter modes:	Event counting, encoder input, period, pulsewidth, duty cycle, frequency measurement
Resolution:	32 bit
Tim base	102.4 MHz
Signal levels:	30 V
CAN inputs	
Number of channels:	2
Specification:	CAN 2.0B, up to 1 MBaud
Physical layer:	High speed
Environmental	
Operating temperature:	0 °C to 50 °C (standard)
Storage temperature:	-20 °C to +70 °C
Relative humidity:	95 % non condensing @ 60 °C
Vibration:	Shape Random
EN 60721-3-2	Frequency range 10 - 200 Hz
Class 2M2	Power spectral density 1 m/s ² / Hz from 10 – 200 Hz
	Duration 30 Minutes per axis
Shock:	Shape Half-sine
EN 60068-2-27	Acceleration amplitude 15 g
	Duration 11 ms
	Test in 3 axis, 3 shocks in each axis and direction
Dimensions (W x D x H):	approx. 230 x 181 x 104 mm (9.06 x 7.12 x 4.09 in.)
Weight:	typ. 3 kg (2.5 kg + DAQP modules) typ. 6.6 lbs (5.5 lbs + DAQP modules)

Main System

Dimensions*

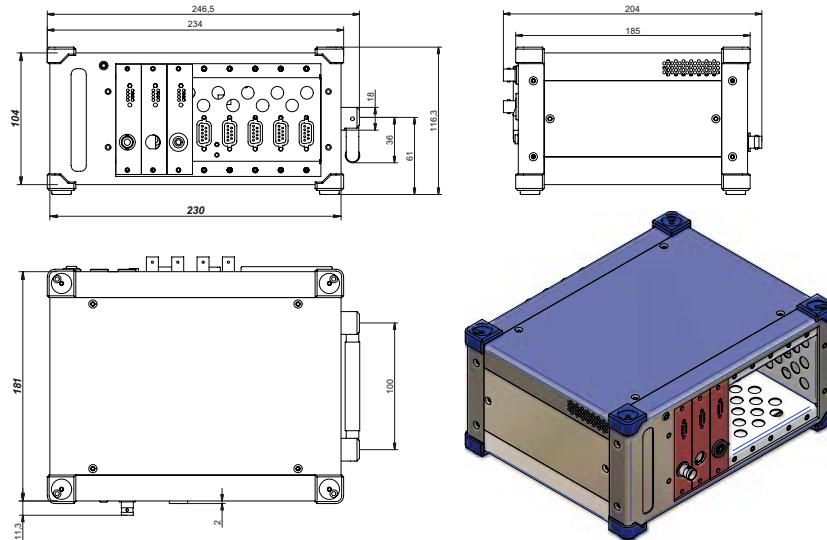

* Dimensions in mm
(1 inch = 25.4 mm)

DEWE-50-USB2-8 at a glance

- | | |
|---|---|
| 1 Power-on switch | 8 Micro-B USB interface connector (to host) |
| 2 Power supply input (EGJ.2B.302) | 9 USB interface connector (to device) |
| 3 Ground connector | 11 CAN interface connector |
| 4 EPAD connector | 10 Sync connector |
| 5 Counter inputs | 12 Status LED |
| 6 Optional conditioned signal output | 13 DAQ/PAD modules |
| 7 Fan outlet | |

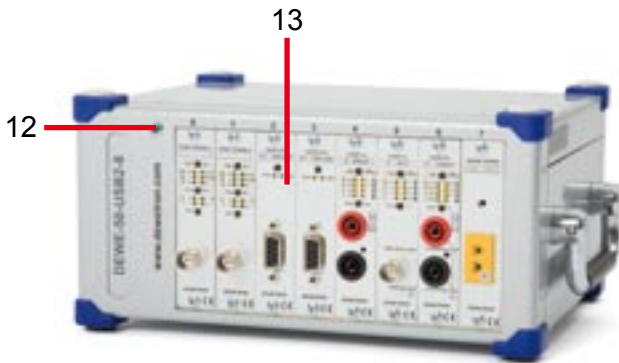

Typical DEWE-USB2-8 front view

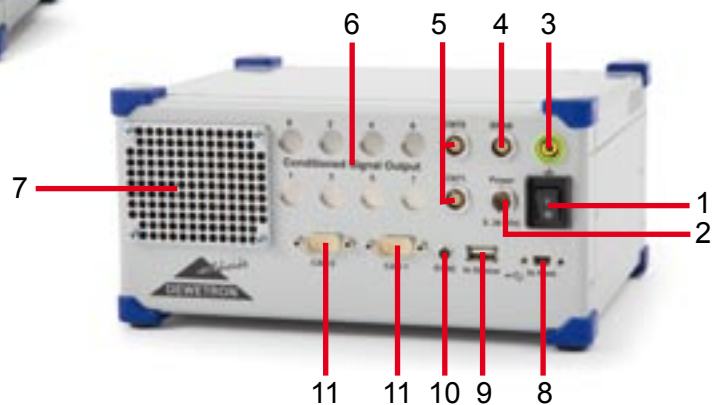

Typical DEWE-50-USB2-8 rear view

Note: The location of the connectors might vary from system to system and depends on system configuration

1 Power-on switch

The power-on switch has to be used to switch on the system.

2 Power supply input connector

For details see chapter power supply.

3 Ground connector

For some kind of measurements, it's necessary to give the system an additional ground connection.

4 EPAD connector

To connect DEWETRON EPAD modules to the system.

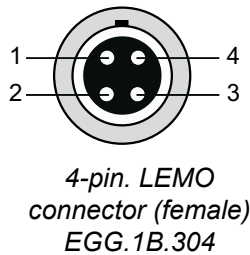

Pin assignment

1: RS-485 A

2: RS-485 B

3: +12 V

4: GND

Shield is connected on housing

Mating connector:

LEMO FGG.1B.304.CLAD52Z (for cable diameter 4.1 to 5.0 mm)

LEMO FGG.1B.304.CLAD62Z (for cable diameter 5.1 to 6.0 mm)

5 Counter inputs

1: Source Bx_CNT(n)

2: Aux_Bx_CNT(n)

3: Gate Bx_CNT(n)

4: Power GND

5: +5 V (max. 500 mA)

6: +12 V (max. 500 mA)

7: Signal GND

n .. channels 0 to 1 of counter board

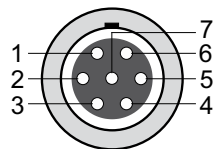

7-pin female LEMO connector
EGG.1B.307

Mating connector:

LEMO FGG.1B.307.CLAD52Z

(for cable diameter 4.1 to 5.0 mm)

LEMO FGG.1B.307.CLAD62Z

(for cable diameter 5.1 to 6.0 mm)

Cable to open end, 5 m long:

CTR-CBL-05

6 Optional conditioned signal output

The conditioned signal output of each DAQP module is available as a ± 5 V signal at 8 BNC connectors on the rear panel of the system.

7 Fan outlet

Do not to cover the fan outlet. The system may overheat and could get damaged!

Further information see chapter 'Changing filter pad'.

8 Micro-B USB interface connector (to host)

The micro-B USB interface connector meets standard micro-B USB pin assignment.

9 USB interface connector (to device)

The USB interface connectors meets standard USB pin assignment.

Main System

10 SYNC interface connector

The SYNC interface connector enables the combination of two DEWE-50-USB2-8 to a 16 channel system.

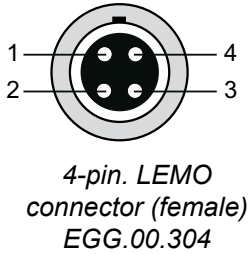

- Pin assignment
- 1: CLK
 - 2: TRG
 - 3: RES
 - 4: DGND

Mating connector: LEMO FGG.00.304.CLAD27Z (for cable diameter 2.1 to 2.6 mm)

11 CAN connectors

This connector supports the CAN signals of the built-in A/D board. If this board does not support CAN signals, the connector is not available.

CAN 0:

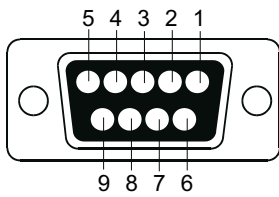

- Pin assignment
- 1: +5 V
 - 2: CAN0_L
 - 3: GND
 - 4: n.c.
 - 5: n.c.
 - 6: GND
 - 7: CAN0_H
 - 8: n.c.
 - 9: +12 V

CAN 1:

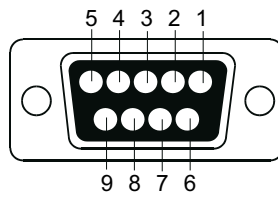

- Pin assignment
- 1: +5 V
 - 2: CAN1_L
 - 3: GND
 - 4: n.c.
 - 5: n.c.
 - 6: GND
 - 7: CAN1_H
 - 8: n.c.
 - 9: +12 V



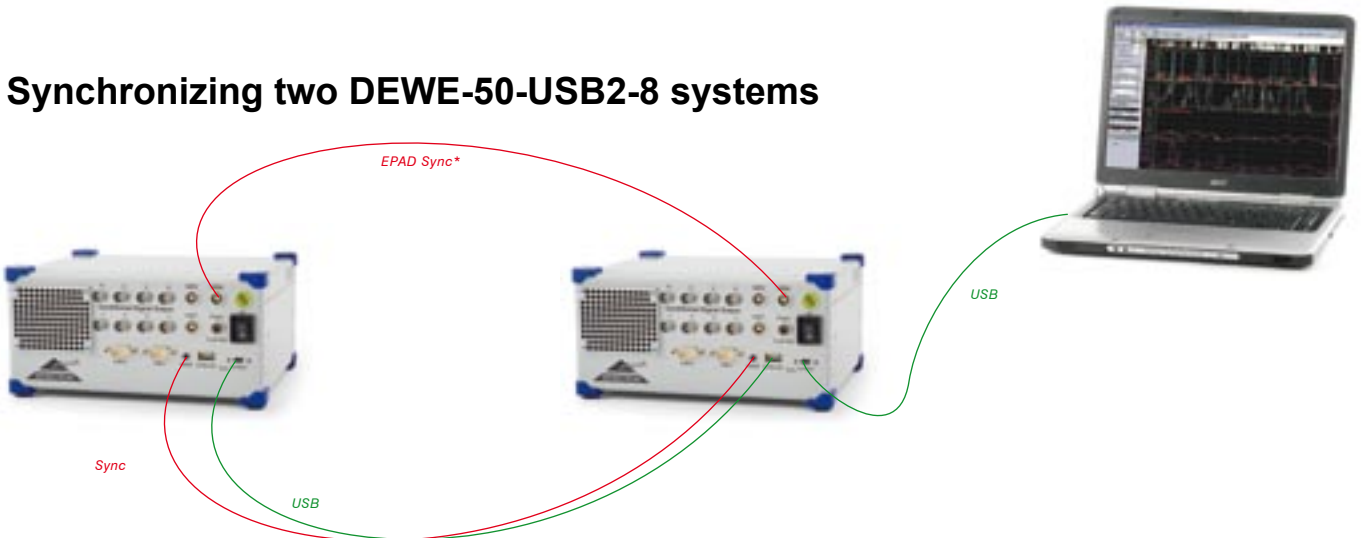



Synchronizing two DEWE-50-USB2-8 systems



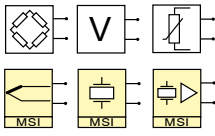
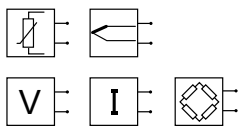



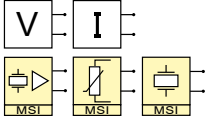
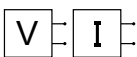



*) For synchronizing the modules of each DEWE-50-USB2-8 an additional EPAD sync cable is necessary.

Note: When synchronizing the modules of each DEWE-50-USB2-8 via EPAD sync cable it is not possible to connect additional PAD/EPAD2 modules.

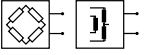
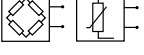
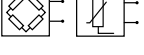
DAQP series amplifiers overview

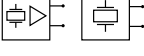
Module	Input type	Ranges	TEDS	Bandwidth (BW), Filters (LP = lowpass, HP = highpass)	Isolation (ISO), Overvoltage protection (OP)
Universal measurement					
DAQP-STG 	Strain gauge, bridge sensors	± 0.1 to ± 1000 mV/V (@ 5 VDC _{exc})	✓	BW: 300 kHz LP: 10 Hz to 300 kHz	ISO: 350 V _{DC} OP: ± 50 V _{DC}
	Piezoresistive bridge	± 0.5 to 10000 mV/mA (@ 1 mA _{exc})			
	Voltage	± 500 μ V to ± 10 V			
	Resistance	25 m Ω to 100 k Ω			
	Pt100, Pt200, Pt500, Pt1000, Pt2000	-200° C to 850° C			
	IEPE® via MSI-BR-ACC	± 2.5 to ± 10000 mV			
	Thermocouple via MSI-BR-TH-x	full range of TC type			
	Charge via MSI-BR-CH-50	up to 50000 pC			
Voltage via MSI-BR-V-200	up to ± 200 V				
DAQP-MULTI 	Thermoresistors	Pt100, Pt200, Pt500, Pt1000 and Pt2000, free programmable range	✓	BW: 3 kHz LP: 3, 10, 30, 100, 300, 1000 Hz	ISO: 1 kV _{RMS}
	Thermocouple	Type K, J, T, R, S, N, E, B, L, C, U free programmable range			
	Resistance	1 Ohm to 1 MOhm			
	Piezoresistive bridge	13 ranges (± 0.5 to 5000 mV/mA)			
	Voltage	10 ranges from ± 5 mV to ± 5 V			
	Current (with external shunt)	depending on external shunt			
High voltage measurement					
DAQP-HV 	High voltage	± 20 to ± 1400 V	-	BW: 300 kHz LP: 10 Hz to 300 kHz	ISO: 1.8 kV _{RMS}
DAQP-HV-S3 	High voltage	± 20 to ± 1400 V	-	BW: 700 kHz LP: 10 Hz to 700 kHz	ISO: 1.8 kV _{RMS}
DAQP-DMM 	High voltage	± 10 to ± 1000 V	-	BW: 20/30 kHz LP: 10 Hz to 30 kHz	ISO: 1.5 kV _{RMS}
Voltage & current measurement					
DAQP-LV 	Voltage	± 10 mV to ± 50 V	✓	BW: 300 kHz LP: 10 Hz to 300 kHz	ISO: up to 1 kV _{RMS} OP: 350 V _{DC}
	Current with external shunt	20 mA / 5 A			
	IEPE® via MSI-V-ACC	± 10 mV to 10 V			
	Pt100, Pt200, Pt500, Pt1000, Pt2000 and resistance via MSI-V-RTD	-200° C to 1000° C and 0 to 6.5 kOhm			
Charge via MSI-V-CH-50	up to 50000 pC				
DAQP-V 	Voltage	10 mV to 50 V	-	BW: 50 kHz LP: 10 Hz to 50 kHz	ISO: up to 1 kV _{RMS} OP: ± 500 V _{DC}
	Current with external shunt	20 mA / 5 A			
DAQN-AIN 	Voltage	± 10 V (1:1 input)	-	-	OP: $< \pm 500$ V (jumper selectable)

Main System

Module	Input type	Ranges	TEDS	Bandwidth (BW), Filters (LP = lowpass, HP = highpass)	Isolation (ISO), Overvoltage protection (OP)
Current measurement					
DAQP-LA-SC 	Current <i>Note:</i> 5 A _{RMS} continuous	0.1 A to 30 A peak max. 5 A _{RMS} contin. current	-	BW: 300 kHz LP: 10 Hz to 300 kHz	ISO: 1.4 kV _{RMS}
DAQP-LA-B 	Current <i>Note:</i> typ. 20 mA application	2 mA to 600 mA	-	BW: 300 kHz LP: 10 Hz to 300 kHz	ISO: 1.4 kV _{RMS}
Bridge / strain gauge and carrier frequency amplifier					
DAQP-CFB 	AC bridge, strain gauge <i>Note:</i> 5 kHz sine wave excitation Inductive sensors, LVDT	Bridge: 0.1 to 1000 mV/V Inductive: 5 to 1000 mV/V	-	BW: DC to 2.3 kHz LP: 10 Hz to 1 kHz	OP: ±10 V _{DC}
DAQP-BRIDGE-A 	Strain gauge, bridge sensors	±1 to ±50 mV/V (@ 5 VDC)	-	BW: 20 kHz LP: 10 Hz to 20 kHz	ISO: 350 V _{DC} OP: ±10 V _{DC}
DAQP-BRIDGE-B 	Strain gauge, bridge sensors Potentiometric sensors	±0.1 to ±100 mV/V (@ 5 VDC) 200 Ω to 10 kΩ	✓ ¹⁾	BW: 200 kHz LP: 10 Hz to 200 kHz	OP: ±10 V _{DC}
Charge / IEPE® measurement					
DAQP-ACC-A 	IEPE® sensors	±50 mV to ±5 V	-	BW: 0.5 Hz to 300 kHz LP: 1 to 300 kHz HP: 0.5 Hz and 5 Hz	-
DAQP-CHARGE-A 	Charge sensors IEPE® sensors <i>Note:</i> selectable integration and double integration	Charge: 5 to 50000 pC IEPE®: ±5 mV to 5 V	-	BW: 0.1 Hz to 50 kHz LP: 100 Hz to 50 kHz HP: 0.1 Hz to 10 Hz	-
DAQP-CHARGE-B 	Charge sensors <i>Note:</i> selectable time constant for static sensors	±100 to ±1 000 000 pC	-	BW: DC to 100 kHz LP: 10 Hz to 100 kHz HP: DC, 0.001 Hz to 0.5 Hz	ISO: 350 V _{DC}
Temperature measurement					
DAQP-THERM 	Thermocouple <i>Note:</i> internal CJC and linearisation	Type K, J, T, R, S, N, E, B, L, C and U selectable free programmable range	-	BW: 3 kHz LP: 3, 10, 30, 100, 300, 1000 Hz	ISO: 1 kV _{RMS}
Frequency measurement					
DAQP-FREQ-A 	Frequency	100 Hz to 200 kHz	-	BW: according to range Output response: 1.5 ms 30 ms 500 ms	ISO: 350 V _{DC}
Voltage output module					
DAQN-V-OUT 	Voltage output	1:1 output module with isolation Input voltage: ±10 V Output voltage: ±10 V	-	BW: 400 Hz	ISO: 240 V _{DC}

¹⁾ TEDS support for DAQP-BRIDGE-B revision 2 only

Power supply

DC standard power supply

50 W DC power supply		AVP-2B/K
Input:		
DC input:	10 to 36 V _{DC}	
Max. input current:	5.6 A	
Output:		
Output power:	max. 48 W	
Output voltages:	+12 V (max. 2 A) -12 V (max. 2 A)	
Protection:	Overvoltage protection, excess temperature protection, polarity reversal protection	
Fuse:	6.3 A	

Power supply pin assignment:

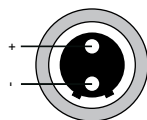

Connector type
2-pin. male
LEMO EGJ.1B.302

Optional cables:

- LEMO 1B jack to LEMO 1B plug, 2 m.
- LEMO 1B jack to banana plugs, 2 m.

DEWE-50-USB2-8 with external AC/DC power supply

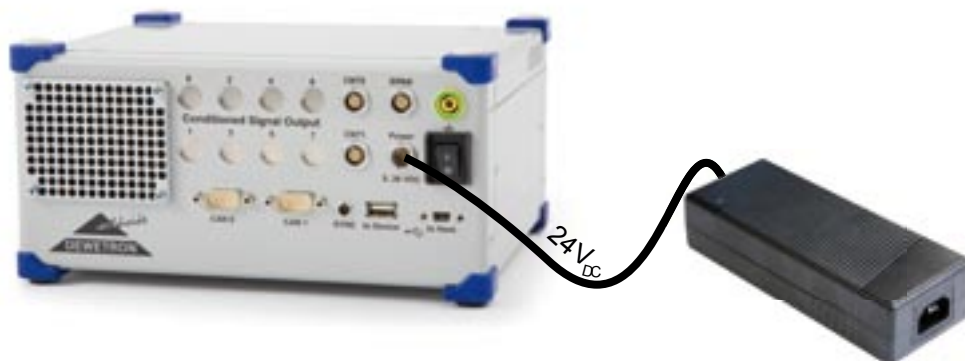

Main System

DEWE-50-USB2-8 installation guide

System requirements

- Windows® 2000® / XP® / 7®
- Intel Pentium 4, 1 GHz processor or higher
- 512 MB RAM
- 50 MB free hard disk space
- USB2.0 port

Hardware driver installation

CAUTION: do not connect the DEWE-50-USB2-8 to the PC until all the drivers are installed!

- 1) Insert the DEWE-System DVD
- 2) Navigate to "Driver"
- 3) Navigate to "DEWE-5x"
- 4) Click on "DAQ-BOARD DRIVER"
- 5) Execute the DEWEUSB2Inst.exe

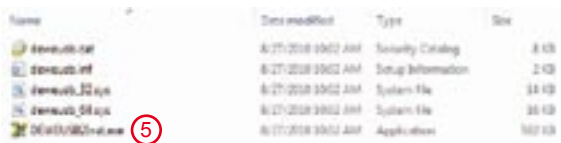

- 6) After this a Windows Security information will popup. Check "Always trust software..." and click the "Install" button.
- 7) In some cases the program compatibility assistant pops up and informs that this program might not have installed correctly. In this case click "This program installed correctly". This will install the basic AD-board driver to your computer.
- 8) After installing the DAQ-BOARD DRIVER return to the System DVD user interface and again navigate to "Driver" - "DEWE-5x". Click on "USB SERIAL BOARD DRIVER".

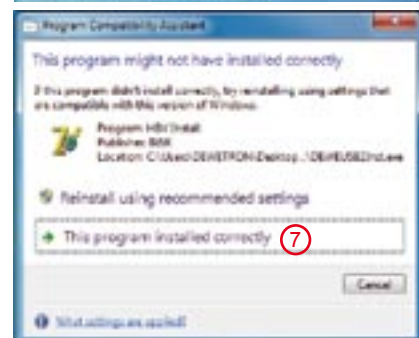
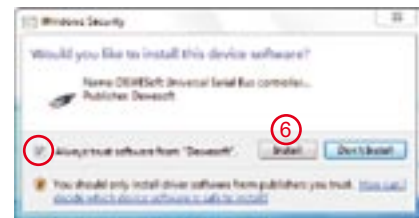

- 9) Execute the setup.exe from the list.

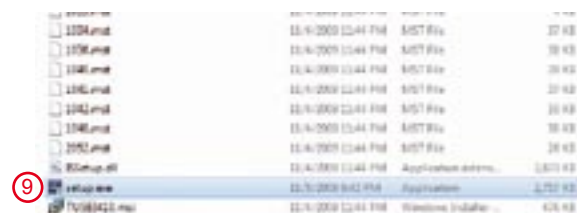

Main System

10) Follow the install shield wizard which will guide you through the rest of the setup process.



11) After the setup process has finished you have to identify the COM-port. For this, click on "Start" - "Control panel" and "System". On the top left click on "Device Manager". Now you can see the used COM-port for the DEWE-USB2-8. This is important for the next step "DEWESoft configuration".

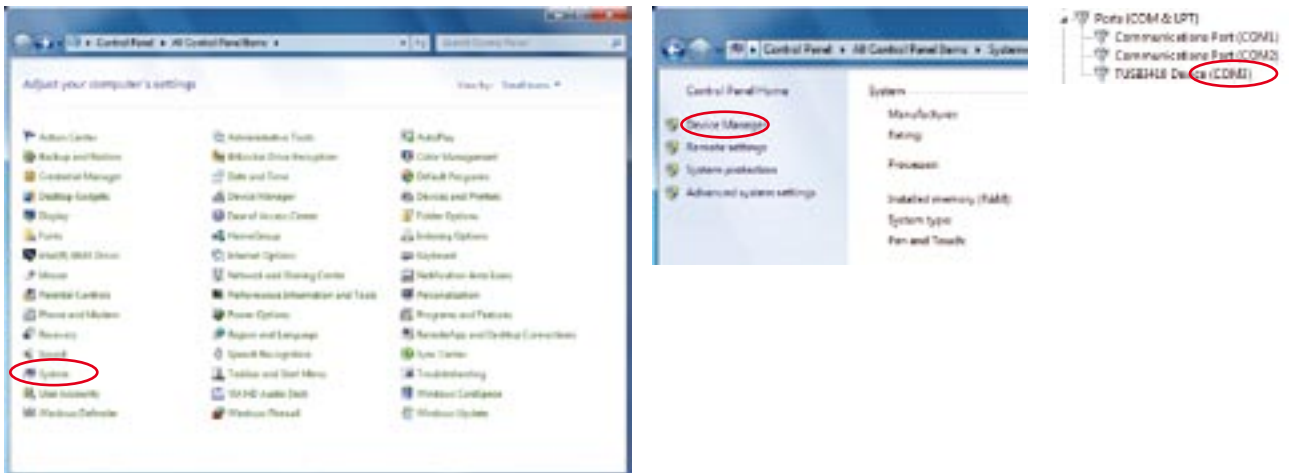

DEWESoft configuration

After installing DEWESoft 7.x you have to make following settings in the hardware setup:

- Select as analog device "DEWESoft USB".
- Select "COM port to offline" as amplifiers and check the amplifiers used in your DEWE-50-USB2-8 (DAQ/PAD modules, MSI adapters).
- Select the corresponding COM port (see point 11 "identify the COM-port").
- Additionally you can check "Forget PAD if not found".

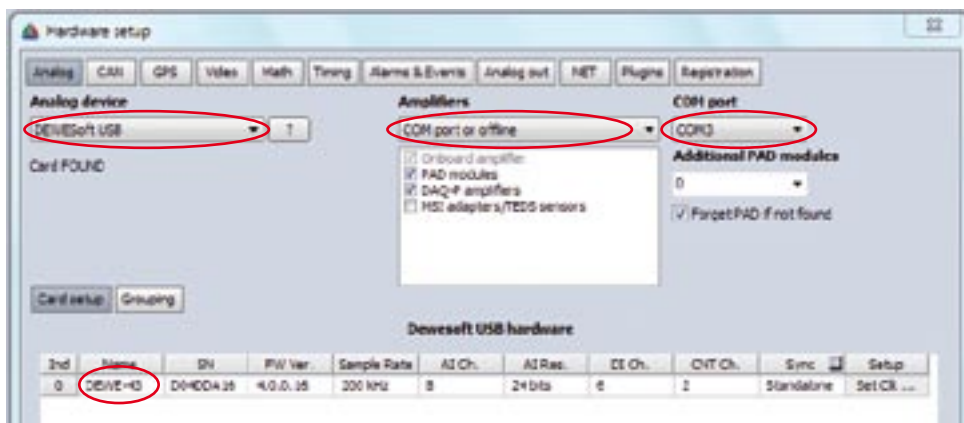

After correct configuration, the DEWE-USB2-8 is detected as DEWE-43.

Main System

CAN setup

In the CAN tab the operation mode of the two CAN interfaces could be configured.



Maintenance

Changing/Cleaning the filter pad

Note: Check the filter pad frequently! A polluted filter pad may cause an overheating of the system! The cleaning interval depends on the environmental conditions.

To clean or exchange the filter pad you only have to open four screws on the rear panel of the system and remove the filter-drawer.



DEWESoft

DEWESoft Software Turns our Hardware into a Powerful Data Acquisition System



Our award-winning data acquisition package is second to none when it comes to both pure recording power and ease of use. Normally it is a difficult balancing act to provide lots of capability and performance, without making the user interface cumbersome and hard to learn. But with careful and innovative design, we have done exactly that!

The software can act as a simple multi-meter or recorder as well as a sophisticated combustion analyzer or power analyzer. Or anything in between these extremes, like a FFT analyzer, transient recorder, etc.

Over 10 years DEWESoft evolved into a great data acquisition software and is Nr.1 in synchronous acquisition of vastly different signals like analog, digital, CAN, GPS, PCM, counter, video, etc. In 2010 with the release of version 7, DEWESoft takes a big step toward become a very powerful data analysis tool for a wide range of test & measurement applications. Since many years you can utilize math channels in the measure mode for online calculations. Starting with version 7.0, captured data can be re-calculated in the analyze mode using the large suite of calculation (math) functions available in the measure mode. This eliminates the CPU performance limitations and thus provides unlimited offline calculation power.

Example: Performing a 10th order notch filter on 128 channels being sampled at 200 kS/s each. This is not possible online. But in analyze mode it's easy. Simply record the data and then filter it afterwards (math functions are non-destructive, i.e., they do not affect the raw channels).

Another important new feature is the sequencer which provides a way to automate test procedures.

Key Features of DEWETRON systems running DEWESoft

- Fast and easy setup
- Perfect sync of vastly different signals like analog, digital, counter, CAN, XCP, GPS, Video, ARINC, 1553, etc.
- Powerful online data processing, MATH functions, filters, statistics, reference curves
- Attractive online display of all kind of data, creation of displays is a matter of seconds
- Analog, digital or CAN data output; powerful function generator, alarms, CAN messages
- Build test procedures in a form of workflow diagram by means of sequencer
- Fast data analysis, reload GByte files in seconds
- Post processing, large suite of calculation (math) functions

DEWESoft

Hardware Support

DEWESoft supports all DEWE-ORION series A/D cards as well as some third-party cards, like Spectrum cards for transient recording. Multiple cards of the same family are supported for high channel counts.

In front of the A/D cards typically comes signal conditioning units, and there is a huge range of DEWETRON conditioners which are all perfectly implemented into the software.

Besides the analog inputs DEWESoft supports the digital I/Os, counters and CAN interfaces of the DEWE-ORION series cards.

To acquire video streams in sync with the analog data there is a selection of DEWE-CAM cameras.

Further bus systems like PCM telemetry, XCP, ARINC, 1553, etc. are supported, too. DEWETRON offers the appropriate hardware for all of these.

For position and speed measurements there is a choice of high performance DEWE-VGPS sensors. Or use low-cost sensor which is NMEA compatible for simple position plotting and mapping applications.



DAQx modules



DEWE-ORION A/D cards

Sensor Database and TEDS (Technical Electronic Data Sheet)

The DEWESoft data acquisition software suite was developed especially for measurement technicians, thus simple sensor “connection” is a major topic. Basic settings like sensor setup are easily done. TEDS technology of newer sensors is supported on both the hardware and software side, so that all settings follow automatically, preventing user errors and saving a huge amount of time. For sensors without TEDS, there are numerous options for manual scaling as well as an integrated sensor database to make settings as efficient as possible.

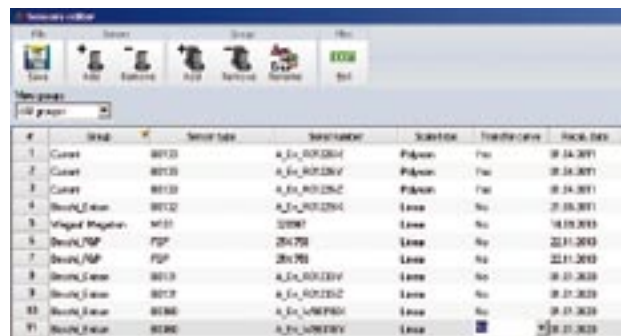

#	SNAP	Unit	Sensor type	Manufacturer	Scale factor	Transfer curve	Scale, Min
1	Current	0010	A/D_0010001	Precision	Yes		0.14.001
2	Current	0010	A/D_0010002	Precision	Yes		0.14.001
3	Current	0010	A/D_0010003	Precision	Yes		0.14.001
4	Strain/Displacement	0012	A/D_0012001	Linear	No		0.15.001
5	Voltage/Resistor	0011	00001	Linear	No		14.00.000
6	Strain/Temp	0013	00470	Linear	No		0.17.000
7	Strain/Temp	0013	00470	Linear	No		0.17.000
8	Strain/Displacement	0012	A/D_0012004	Linear	No		0.17.000
9	Strain/Displacement	0012	A/D_0012002	Linear	No		0.17.000
10	Strain/Displacement	0012	A/D_0012003	Linear	No		0.17.000
11	Strain/Displacement	0012	A/D_0012005	Linear	No		0.17.000

Video Recording

A camera is a perfect sensor for many applications and a lot of people like to use it in their data acquisition. Video is a useful test documentation, providing a visual record of the test conditions and setup. It can also be used for more in-depth analysis, as you can imagine. There is nothing quite like seeing your data replayed with synchronized video – this DEWETRON innovation provides a whole new level of context and understanding of your test data than you could ever imagine.



3D Graph

In the properties panel there is a function that allows you to edit the properties of the selected display, and to create new displays, and rearrange them. You can rename any display, and select a different icon for it. Of course you can add sub-displays to any main display.

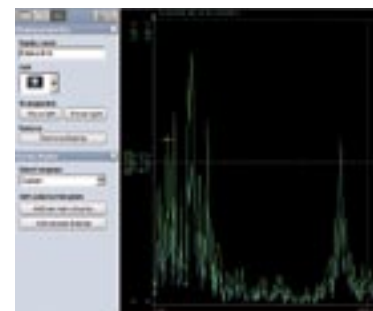

Display Screens

One of the most powerful and yet easy to use aspect of DEWESoft is the creation of displays. Of course a few standard displays like Recorders, Oscilloscope, FFT, Meters, Bars, 2D and 3D graphs, etc. are built-in for you. But this is only the beginning. You simply can create custom displays according to the needs of specific test.

Project Setup

The project files setup the measurement instruments in seconds including complete hardware setup, measurement configuration, and sensor calibration.

Since DEWESoft version 7 you can create “Projects” at the hardware setup screen level, where each project contains all of the settings for any hardware that you own. You can have an unlimited number of hardware setups, which you can freely name and edit. When you start DEWESoft 7, it will automatically load the last hardware setup that you used, of course ... but if you have changed the hardware, you can simply choose a different project from the “Settings” menu, and a completely different hardware setup will be loaded.



Even when using the same hardware, projects allows using different folders for setup, data and exported files. So you can create John and George projects for different users and work without interfering or you can create e.g. Road-Load and DSA projects for different tasks.

Recording

You can control recording as simple as pressing the START, STORE and STOP buttons. But there are also versatile trigger options to e.g. only store data if a trigger event occurs or to store at a slow rate usually but store at a fast rate at a trigger event with definable pre- and post times.

There is a large suite of calculation (math) functions which can be applied to any channels.



Analyze – Replay, Re-calculate, Export

In Analyze mode you can replay any captured data file, zoom in, make cursor measurements, print reports and export the data to a wide variety of formats, like Flexpro, Excel, Matlab, Diadem and many more.

Since version 7 all the powerful math functions such as math formulas, filtering, statistics, power analysis, frequency response function, order tracking, torsional vibration, engine combustion analysis, sound analysis, human vibration analysis, and others can also be applied off-line to captured data. So you can simply store the raw data and do all the processing off-line, on any computer, anywhere. This allows you to work with the data as you were at the test bench or on the proving ground.

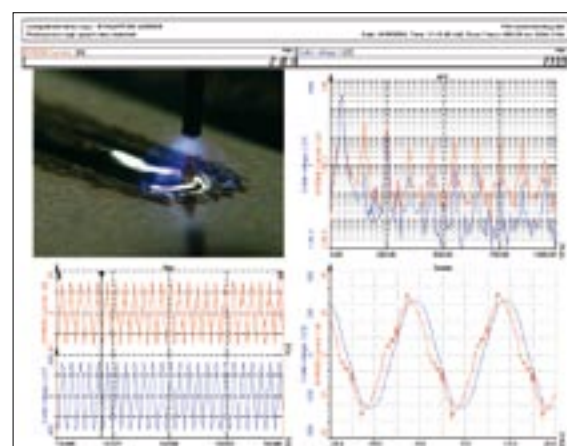

Notes

8 slot DEWE-MOTHERBOARD

I/O connectors

Ixx: Analog input xx (leads to DAQ-module pin 1 in slot xx)
 Oxx: Analog output xx (leads to DAQ-module pin 7 in slot xx)
 G: GND (reference for A/D card)
 68-pin high-density sub-D connector

Baud rate for onboard RS-232/485 converter

1	115000
2	57600
3	38400
4	19200
5	9600
6	4800
7	2400

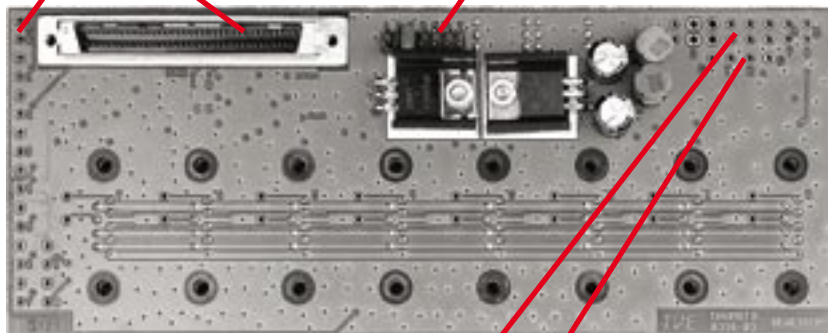

Rear view

Supply voltages, RS-485 connection

- 1 +12 V (supply voltage)
- 2 GND (system ground)
- 3 GND (referenced ground)
- 4 -12 V (supply voltage)
- 5 +Vcc (sensor supply, normally +12 V, leads to DAQ-module pin 6)
- 6 -Vcc (normally not connected, leads to DAQ-module pin 8)
- 7 A (RS-485)
- 8 B (RS-485)

RS-232 connection

- G GND
- T Transmit
- R Receive
- G GND

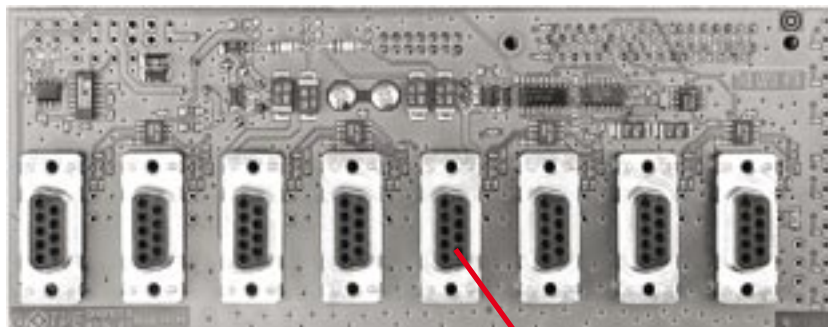

Front view (connectors for DAQ-modules)

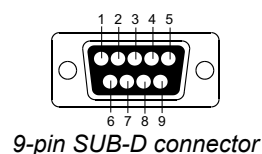

Interface pin assignment:

- 1 Module input (± 5 V)
- 2 RS-485 (A)
- 3 RS-485 (B)
- 4 GND
- 5 +9 V power supply
- 6 +12 V power / sensor supply
- 7 Module output (from A/D board)
- 8 reserved
- 9 -9 V power supply

The 8 slot DEWE-MOTHERBOARD receives the ± 12 V_{DC} power supply via a DC/DC converter from the internal power supply.

Internal Wiring

Notes

CE-Certificate of conformity



Manufacturer: **DEWETRON Elektronische Messgeraete Ges.m.b.H.**

Address: **Parkring 4
A-8074 Graz-Grambach Austria**

Tel.: +43 316 3070 0

Fax: +43 316 3070 90

e-mail: sales@dewetron.com

http://www.dewetron.com

Name of product: **DEWE-50-USB2-8**

Kind of product: *Data acquisition instrument*

The product meets the regulations of the following EC-directives:

73/23/EEC

"Directive on the approximation of the laws of the Member States relating to electrical equipment designed for use within certain voltage limits amended by the directive 93/68/EEC"

89/336/EEC

"Directive on the approximation of the laws of the Member States relating to electromagnetic compatibility amended by the directives 91/263/EEC, 92/31/EEC, 93/68/EEC and 93/97/EEC"

The accordance is proved by the observance of the following standards:

L V E M C	Safety	IEC/EN 61010-1:1992/93 IEC/EN 61010-2-031	IEC 61010-1:1992/300 V CATIII PoI. D. 2 IEC 1010-2-031
	Emissions	EN 61000-6-4	EN 55011 Class B
	Immunity	EN 61000-6-2	Group standard

Graz, October 14, 2008

Place / Date of the CE-marking

Dipl.-Ing. Roland Jeutter / Managing director

Notes
