



Dewe-43

Technical reference manual



Thank you!

Thank you very much for your investment in our unique data acquisition systems.

These are top-quality instruments which are designed to provide you years of reliable service. This guide has been prepared to help you get the most from your investment, starting from the day you take it out of the box, and extending for years into the future.

1 Table of contents

1 Table of contents.....	2
2 Safety Instructions.....	3
Restriction of Hazardous Substances	6
3 Specifications	9
4 Device operation	19
4.1 Connectors.....	20
4.2 Typical sensor connection	21
Bridge sensor connection	23
5 Driver installation.....	26
6 Using DEWE 43 in Dewesoft	28
6.1 Before using the device	28
6.2 Hardware setup.....	28
6.2.1 Start up of the device.....	29
6.3 Using analog/counter/digital/CAN inputs	31
7 Firmware upgrade	33
8 Dewesoft LICENSE INFORMATION	34

2 Safety Instructions

The information contained in this document is subject to change without notice.

DEWESOFT d.o.o.. (DEWESOFT) shall not be liable for any errors contained in this document. DEWESOFT MAKES NO WARRANTIES OF ANY KIND WITH REGARD TO THIS DOCUMENT, WHETHER EXPRESS OR IMPLIED. DEWESOFT SPECIFICALLY DISCLAIMS THE IMPLIED WARRANTIES OF MERCHANTABILITY AND FITNESS FOR A PARTICULAR PURPOSE. DEWESOFT shall not be liable for any direct, indirect, special, incidental, or consequential damages, whether based on contract, tort, or any other legal theory, in connection with the furnishing of this document or the use of the information in this document.

Warranty Information:

A copy of the specific warranty terms applicable to your DEWESOFT product and replacement parts can be obtained from your local sales and service office.

Support

<p>Please contact: DEWESOFT d.o.o. Gabrsko 11a 1420 Trbovlje SLOVENIA Tel.: +386 356 25 300 Fax: +386 356 25 301 Web: http://www.dewesoft.org The telephone hotline is available Monday to Friday between 08:00 and 15:00 CET (GMT +1:00)</p>

Restricted Rights Legend:

Use Slovenian law for duplication or disclosure.
DEWESOFT d.o.o.
Gabrsko 11a
1420 Trbovlje
Slovenia

Printing History:

Version 2.1
Released AUG, 2010

Copyright © 2009 DEWESOFT d.o.o.

This document contains information which is protected by copyright. All rights are reserved. Reproduction, adaptation, or translation without prior written permission is prohibited, except as allowed under the copyright laws. All trademarks and registered trademarks are acknowledged to be the property of their owners.

Safety symbols in the manual:

WARNING Calls attention to a procedure, practice, or condition that could cause body injury or death.

CAUTION Calls attention to a procedure, practice, or condition that could possibly cause damage to equipment or permanent loss of data.

WARNINGS

The following general safety precautions must be observed during all phases of operation, service, and repair of this product. Failure to comply with these precautions or with specific warnings elsewhere in this manual violates safety standards of design, manufacture, and intended use of the product. DEWESOFT d.o.o. assumes no liability for the customer's failure to comply with these requirements.

All accessories shown in this document are available as option and will not be shipped as standard parts.

Environmental Considerations

Information about the environmental impact of the product.

Product End-of-Life Handling

Observe the following guidelines when recycling a DEWESOFT system:

System and Components Recycling

Production of these components required the extraction and use of natural resources. The substances contained in the system could be harmful to your health and to the environment if the system is improperly handled at its end of life! Please recycle this product in an appropriate way to avoid an unnecessary pollution of the environment and to keep natural resources.



This symbol indicates that this system complies with the European Union's requirements according to Directive 2002/96/EC on waste electrical and electronic equipment (WEEE). Please find further information about recycling on the DEWESOFT web site www.dewesoft.org

Restriction of Hazardous Substances

This product has been classified as Monitoring and Control equipment, and is outside the scope of the 2002/95/EC RoHS Directive. However we take care about our environment and the product is lead free.

Safety instructions for all DEWESOFT systems

- The DEWESOFT data acquisition systems may only be installed by experts.
- Read your manual before operating the system.
- Observe local laws when using the instrument.
- Ground the equipment: For Safety Class 1 equipment (equipment having a protective earth terminal), a non interruptible safety earth ground must be provided from the mains power source to the product input wiring terminals or supplied power cable.
- DO NOT operate the product in an explosive atmosphere or in the presence of flammable gases or fumes.
- DO NOT operate damaged equipment: Whenever it is possible that the safety protection features built into this product have been impaired, either through physical damage, excessive moisture, or any other reason, REMOVE POWER and do not use the product until safe operation can be verified by service-trained personnel. If necessary, return the product to DEWESOFT sales and service office for service and repair to ensure that safety features are maintained.
- Keep away from live circuits: Operating personnel must not remove equipment covers or shields. Procedures involving the removal of covers or shields are for use by service-trained personnel only. Under certain conditions, dangerous voltages may exist even with the equipment switched off. To avoid dangerous electrical shock, DO NOT perform procedures involving cover or shield removal unless you are qualified to do so.
- No modifications are allowed at the instrument. The fuse in the power module has to be replaced by the same type. For continued protection against fire, replace the line fuse(s) only with fuse(s) of the same voltage and current rating and type. DO NOT use repaired fuses or short-circuited fuse holder labels and print on the power module may not be removed.
- DO NOT service or adjust alone. Do not attempt internal service or adjustment unless another person, capable of rendering first aid and resuscitation, is present.

- DO NOT substitute parts or modify equipment: Because of the danger of introducing additional hazards, do not install substitute parts or perform any unauthorized modification to the product. Return the product to DEWESOFT sales and service office for service and repair to ensure that safety features are maintained.
- Before opening the instrument (experts only) or exchanging the fuse in the power module disconnect power!
- Don't touch internal wiring!
- Don't use higher supply voltage than specified!
- Use only original plugs and cables for harnessing.
- You may not connect higher voltages than rated to any connectors.
- The power-cable and connector serve as Power-Breaker. The cable must not exceed 10 feet, disconnect function must be possible without tools.
- Safety of the operator and the unit depend on following these rules.

3 Specifications

Analog inputs	
Number of channels	8
Inputs	Voltage, bridge (IEPE, temperature with adapters)
ADC type	24 bit sigma delta with anti-aliasing filter (see section ADC)
Sampling rate	simultaneous 200kS/sec sampling rate
Input type	Differential
Input ranges	$\pm 10V$, $\pm 1V$, $\pm 100mV$, $\pm 10mV$
Sensor supply	12V, 400mA sensor supply $\pm 5V \pm 0.1\%$ bridge sensor supply
Overvoltage protection	$\pm 70V$ input protection
Dynamic range	107dB@ $\pm 10V$ range
DC accuracy	0,05% of value
10 V range	+1 mV
1 V range	+0.2 mV
100 mV range	+0.1 mV
10 mV range	+0.1 mV
Input impedance	20M Ω 47pF(differential) 10M Ω 33pF(common mode)
CMRR	>80dB (see section CMRR)
Maximum common mode voltage	$\pm 13V$
Signal to noise	
0.1kS/s to 51.2kS/s	105dB
51.2ks/s to 102.4kS/s	100dB
102.4kS/s to 200kS/s	75dB

DEWE-43

Counter/Digital inputs	
Number of channels	8 counters/24 digital input, fully synchronized with analog
Modes	counting, waveform timing, encoder, tacho, geartooth sensor
Counter timebase	50MHz
Counter resolution	32-bit
Compatibility	TTL/CMOS
Configuration	Pull-up with 100kΩ
Input low level	-0,7V to 0.7V
Input high level	2V to 5V
Overvoltage protection	±30V input protection
CAN bus	
Number of ports	2
Interface type	CAN 2.0B, up to 1 MBit/sec
Special applications	OBDII, J1939, CAN output
Galvanic isolation	Not isolated
Bus pin fault protection	±36V
ESD protection	8kV
General specifications	
Power supply	6-36 V DC
Maximum sensor power consumption	6 W
Maximum power consumption	11W
Interface	USB 2.0 interface
Physical dimensions	225x80x45 mm
Weight	720 g
Operating temperature	-20 to 60 deg. C
Storage temperature	-40 to 85 deg. C
Humidity	95% RH non condensing @ 60°C

Analog input configuration:

Block diagram of analog input (all analog inputs are identical):

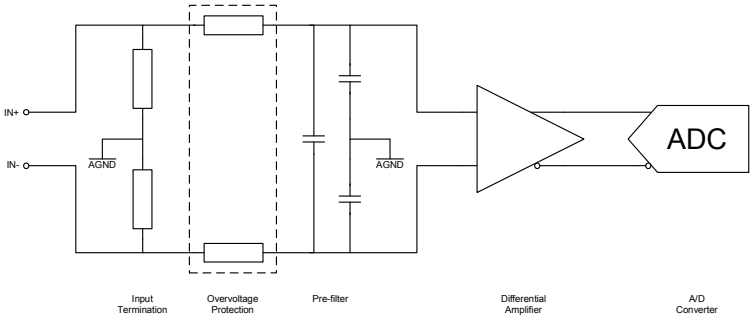

The high input impedance (10MΩ ground referenced) has no distortion influence on the measured signal.

ADC:

The DEWE-43 uses 8 delta-sigma A/D converters. If you sample with a data rate of 102.4 kS/s, the ADC actually samples the input signal with 13.1072 MS/s (multiply the data rate with 128) and produces 1-bit samples which are applied to the digital filter. The filter expands the data to 24-bits and rejects signal parts greater than 51.2 kHz (Nyquist frequency). It also re-samples the data to the more conventional rate of 102.4 kS/s.

A 1-bit quantizer introduces many quantization errors to the signal. The 1-bit, 13.1072 MS/s from the ADC carry all information to produce 24-bit samples at 102.4 kS/s. The delta-sigma ADC converts from high speed to high resolution by adding much random noise to the signal. In this way the resulting quantization noise is restricted to frequencies above 100 kHz. This noise is not correlated with the useful signal and is rejected by the digital filter.

ADCs can only represent signals of a limited bandwidth. The maximum frequency you can represent is the half of the sampling rate. This maximum frequency is also called Nyquist frequency. The bandwidth between 0 Hz and the Nyquist frequency is called Nyquist bandwidth. Signals exceeding this frequency range can not be converted correctly by the sampler.

DEWE-43

For example, the sample rate is 1000 S/s, the Nyquist frequency is 500 Hz. If the input signal is a 375 Hz sine wave, the resulting samples represent a 375 Hz sine wave. If a 625 Hz sine wave is sampled, the resulting samples represent a 375 Hz sine wave too. This happens because signals exceeds the Nyquist frequency (500 Hz). The represented frequency of the sine wave is the absolute value of the difference between the input frequency and the closest integer multiple of the sampling rate (in this case 1000 Hz).

When the sampler modulates frequencies out of the Nyquist bandwidth back to the 0 to 500 Hz baseband it is called aliasing. Signals which are not pure sine wave can have many components (harmonics) above the Nyquist frequency. These harmonics are erroneously aliased back to the baseband, added to parts of the accurately sampled signal and produces a distorted data set. To block frequencies out of the Nyquist bandwidth, a lowpass filter is applied to the signal before it reaches the sampler.

Each input channel has its two pole anti-alias lowpass filter with a cutoff frequency of about 250 kHz. The very high cutoff frequency allows an extremely flat frequency response in the bandwidth of interest and a small phase error. The analog filter precedes the analog sampler. The analog sampler operates at 256 times the selected sample rate for rates below 51.2 kS/s, 128 times for rates between 51.2 kS/s and 102.4 kS/s. For rates over 102.4 kS/s the oversampling is 64 times. That means, the ADC operates at 13.1072 MS/s if you select a sample rate of 102.4 kS/s ($128 * 102.4 \text{ kS/s}$).

The 1-bit oversampled data is passed to a digital anti-aliasing filter. This filter has no phase error and an extremely flat frequency response. It also has an extremely sharp roll-off near the cutoff frequency (0.38 to 0.494 times the sample rate) and the rejection above 0.5465 times the sample rate is greater than 92 dB. The output stage of the digital filter resamples higher frequencies to 24-bit samples.

The digital filter passes only signal components within the Nyquist bandwidth or within multiples of the Nyquist bandwidth of 64, 128 or 256 times (depending on sampling rate). The analog filter rejects most noise near these multiples. The following diagrams show the frequency response of the input circuitry.

Sample rate 0.1kS/s to 51.2kS/s:

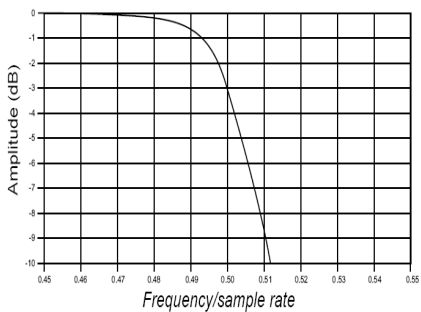
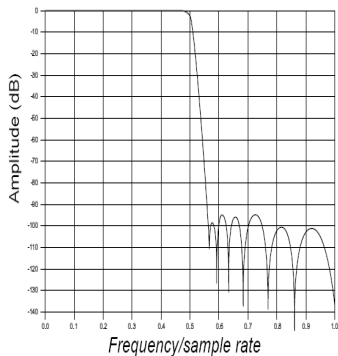

Sample rate 51.2kS/s to 102.4kS/s:

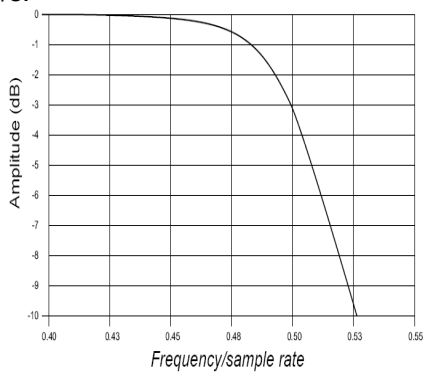
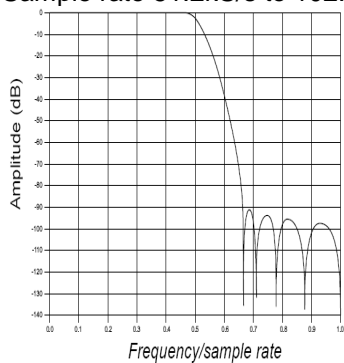

DEWE-43

Sample rate 102.4kS/s to 200kS/s:

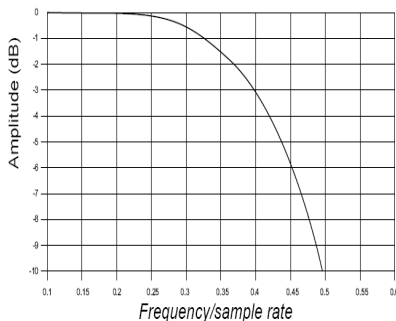
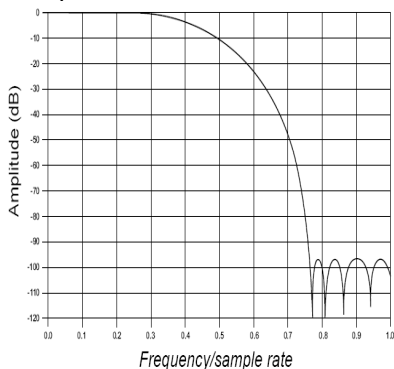

The ADC samples at 64, 128 or 256 times the data rate (depending on the adjusted sample rate). Frequency components above one half of the oversampling rate ($> 32, 64$ or 128) can alias. Most of this frequency range is rejected by the digital filter. The filter can not reject components that lie close to integer multiples of the oversampling rate because it can not differentiate these components from components between 0 Hz and the Nyquist frequency. That means, if the sample rate is 100 kS/s and a signal component is between 50 kHz and 12.8 MHz (128×100 kHz), this signal will be aliased into the passband region of the digital filter and is not rejected. The analog filter removes these components before they get to the digital filter and the sampler.

If aliasing is caused by a clipped or overranged waveform, (exceeding the voltage range of the ADC) it can't be rejected with any filter. The ADC assumes the closest value to the actual value of the signal in its digital range when the signal is clipping. The result of clipping is also a sudden change in the signal slope and results in corrupt digital data with high-frequency energy. This energy is spread over the complete frequency spectrum and is aliased back into the baseband. Do not allow the signal to exceed the input range to avoid this.

Idle channel noise (input terminated with 50Ω):

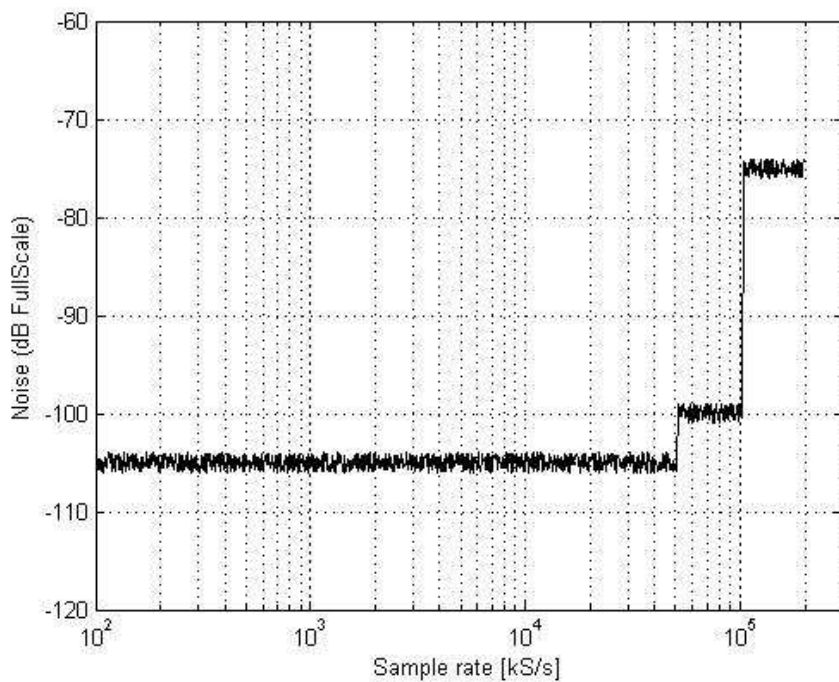

DEWE-43

Spectral noise - 50Ω termination – 8 averages – 16k lines@50kS/s:

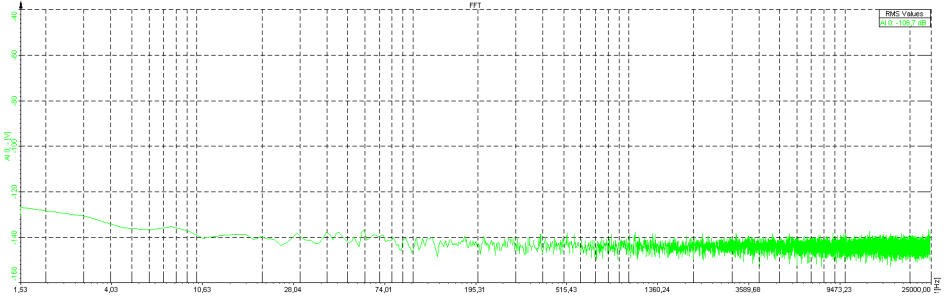

Spectral noise - 50Ω termination – 10 averages – 16k lines@100kS/s:

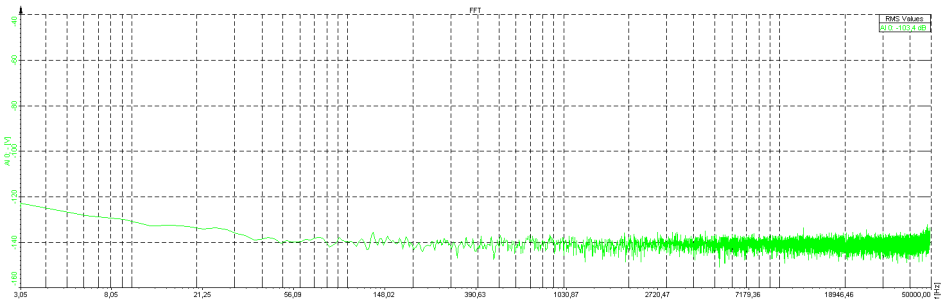

Spectral noise - 50Ω termination – 10 averages – 16k lines@200kS/s:

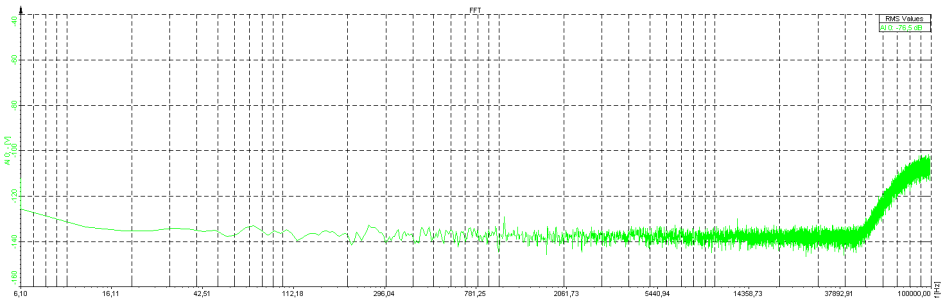

CMRR:

All 8 analog channels of the DEWE-43 are fully differential inputs with resistance of $10M\Omega||10pF$. The input voltage range is $\pm 10V$, $\pm 1V$, $\pm 100mV$ and $\pm 10mV$. Because of the differential input structure, the difference of the input (Ch x(+)- Ch x(-)) will be shown as the result of the measurement. Although the input is protected for input voltages to $\pm 70V$, the common voltage range of each input is limited to about $\pm 13V$. If the input voltage exceeds this range, the result is not valid even when the difference input voltage is lower than current input range. These voltage ranges will be clipped and introduced as large errors that can be easily identified in frequency spectrum. The figure below show the allowable common-mode input voltages for various input voltages and measurement ranges.

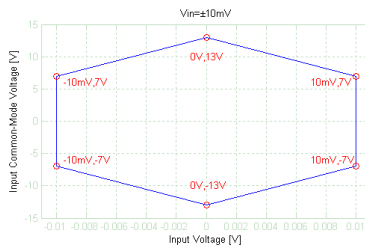
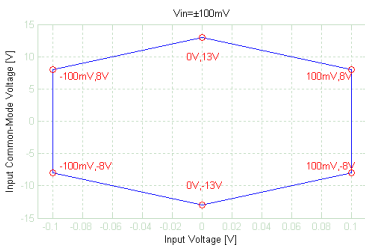
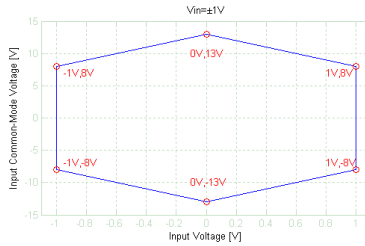
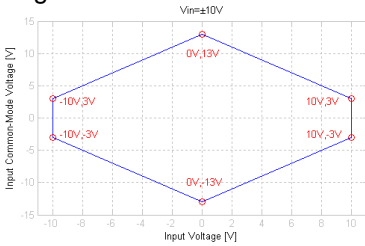

Example:

Many signal sources (function generators) and power supplies are floating sources. That means that they are isolated from each other and from AC power line. If we connect a sensor with differential output and floating power supply to measurement device, then GND of sensor and measurement device can have different voltage potential. This is what the measurement device see as common-mode voltage. This common-mode voltage can range from few volts to few hundred volts, but in almost all cases this renders the measurement. To prevent this effect, GND signals of the sensor and measurement device need to be directly connected. That way we eliminate common-mode voltage. On DEWE-43 this connection is possible over connector GND wire or over "Common GND" receptacle on the housing.

DEWE-43

Counter and digital inputs:

The DEWE-43 is suited with synchronous 32-bit advanced counter and digital inputs. In addition to the basic counter function like simple event counting, up/down counting and gated event counting also period time, pulse width, two-edge separation, frequency and all encoder measurements are supported. All counter inputs can also be used as digital inputs. In addition to the basic counter input selections, ADC Clock can also be used as counter source. The figure bellow shows the block diagram of the counter and input overvoltage protection.

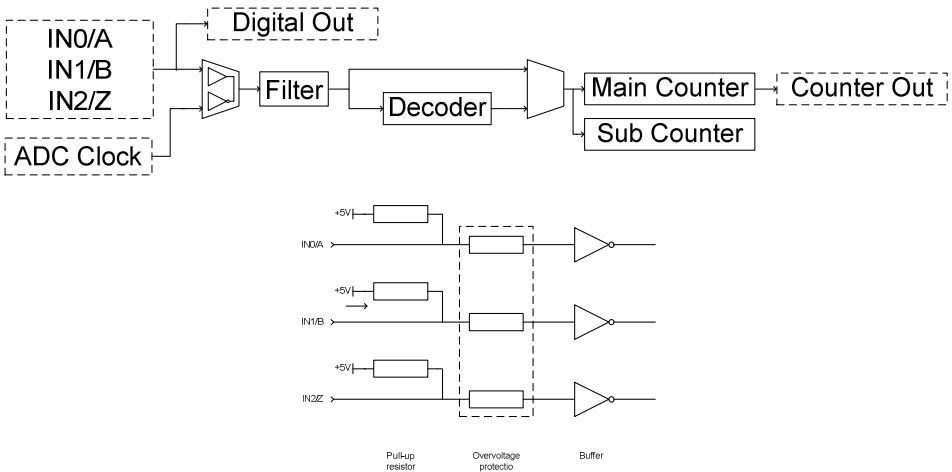

4 Device operation

Top side connectors



Side connectors

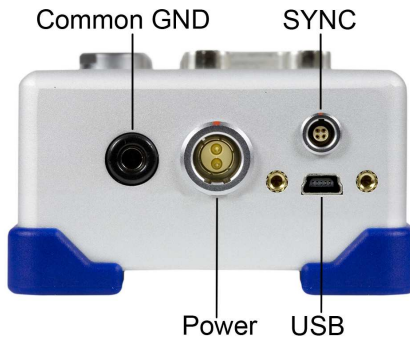

DEWE-43

4.1 Connectors

9-pin D-SUB female connector for analog input:

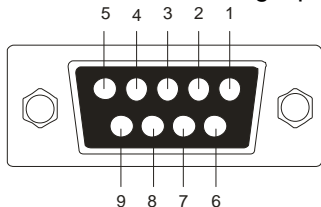

- Pin Assignment
- 1: EXC+
 - 2: IN+
 - 3: Sense-
 - 4: AGND
 - 5: +12V
 - 6: Sense+
 - 7: IN-
 - 8: EXC-
 - 9: TEDS

9-pin D-SUB male connector for CAN bus:

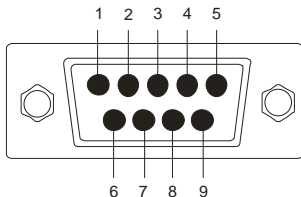

- Pin Assignment
- 1: +5V
 - 2: CAN_LOW
 - 3: DGND
 - 4: RES
 - 5: :RES
 - 6: DGND
 - 7: CAN_HIGH
 - 8: RES
 - 9: +12V

Counter input (mating cable connector: FGG.1B.307CLAD52)

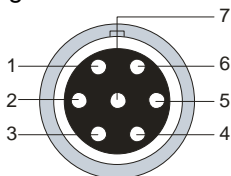

- Pin Assignment
- 1: IN0/A
 - 2: IN1/B
 - 3: IN2/Z
 - 4: RES
 - 5: +5V
 - 6: +12V
 - 7: DGND

Power supply (mating cable connector: FGJ.1B.302CLLD42Z)

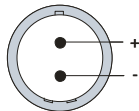

LEMO EGJ.1B.302.CLA

Sync connector (mating cable connector: FGG.00.304CLAD27Z)

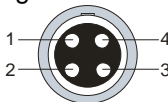

- Pin Assignment
- 1: CLK
 - 2: Trigg
 - 3: RES
 - 4: DGND

LEMO EGG.00.304.CLL

4.2 Typical sensor connection

For correct measurements, it is highly recommended to ground the DEWE-43 with GND banana plug on the side.

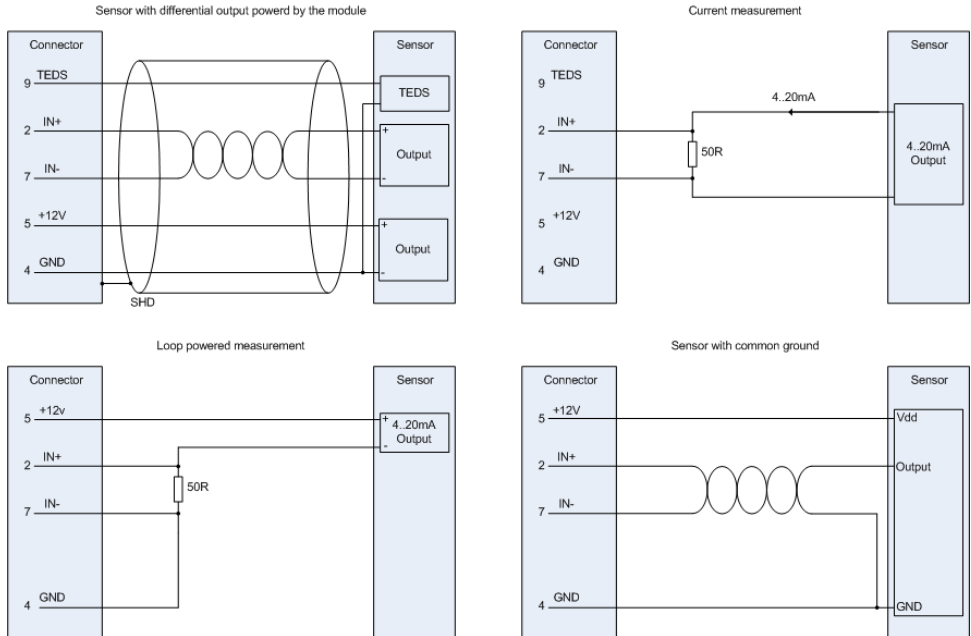

DEWE-43

Single ended connection

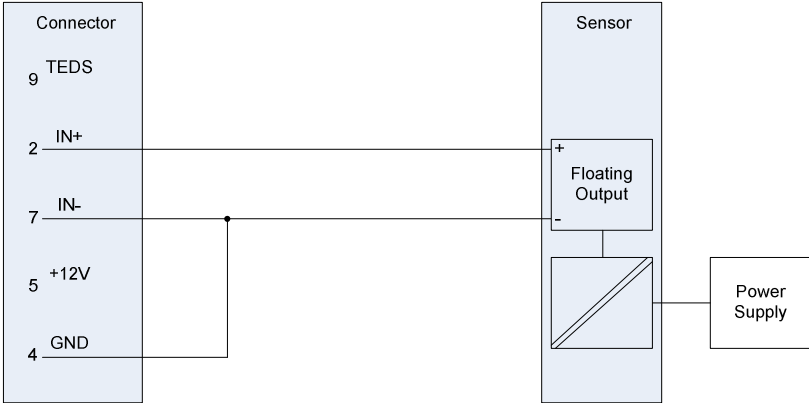

Potentiometer sensor connection

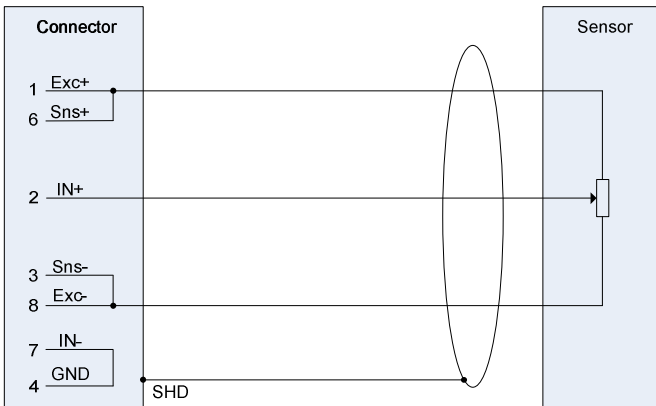

Important: If sensors or other signal sources with isolated external power supply are used, ground signals of DEWE-43 and external power supply should be connected over connector GND wire or over “common GND” input on housing to prevent common-mode voltage problems.

Bridge sensor connection

Full bridge 10V excitation:

6-wire sensor connection

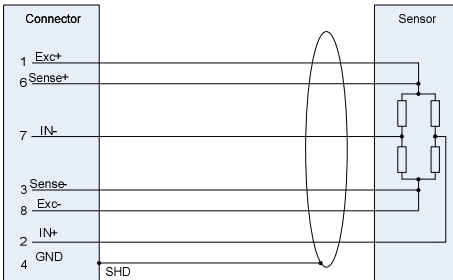

4-wire sensor connection

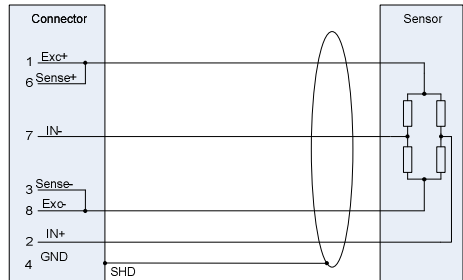

Half bridge 10V excitation:

3-wire sensor connection

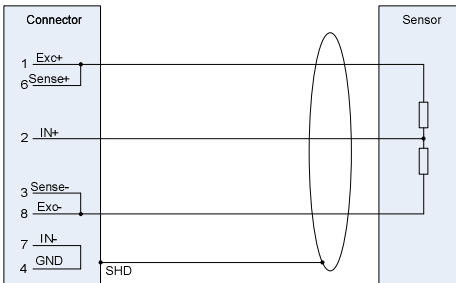

3-wire sensor connection

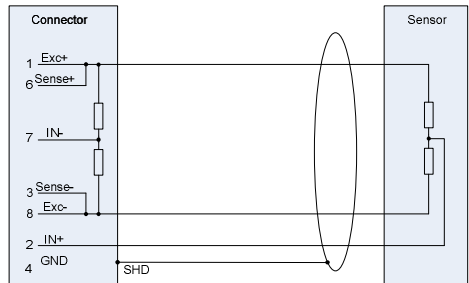

Note: Bridge completion needs to be done in the connector.

DEWE-43

Quarter bridge 10V excitation:

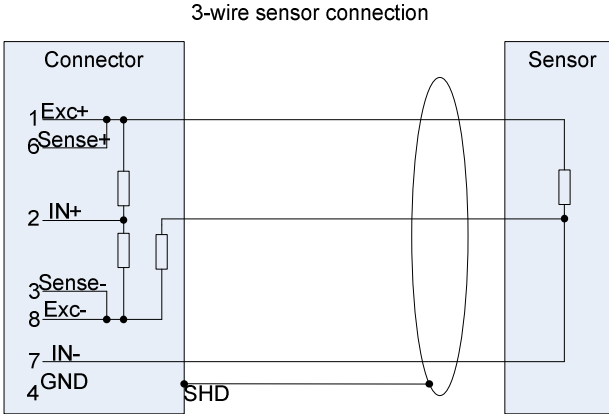

Note: Bridge completion needs to be done in the connector.

Full bridge 5V excitation:

The excitation level between EXC+ and EXC- is 10 V. If lower excitation (5V) is needed, please connect the GND pin instead of EXC- to negative sensor supply.

5V bridge sensor connection

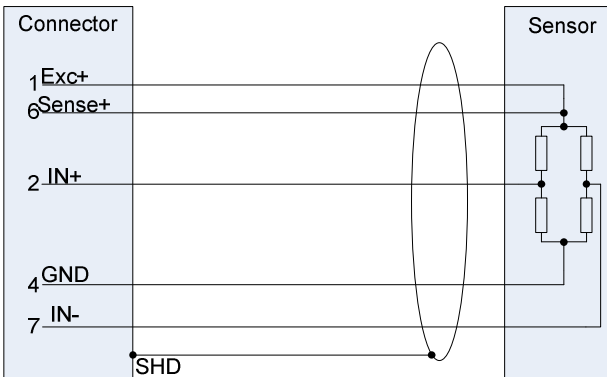

Dewesoft bridge completion adapters:

3-wire sensor connection with DeweSoft
 $\frac{1}{4}$ Bridge Completion Adapter

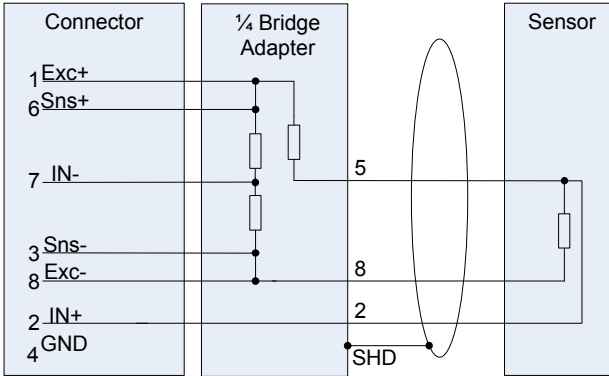

3-wire sensor connection with DeweSoft
 $\frac{1}{2}$ Bridge Completion Adapter

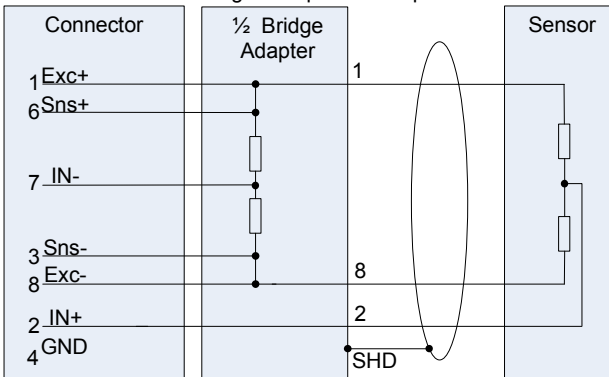

5 Driver installation

To install the driver of DEWE43, please connect the device to the PC with USB cable. If the driver is not installed, the following message will appear:

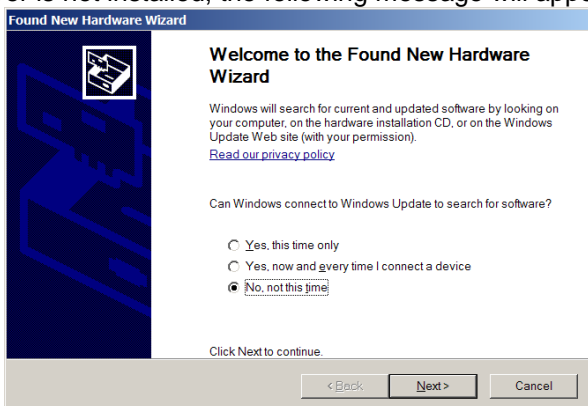

Press »**No, not this time**« and click **Next** to continue.

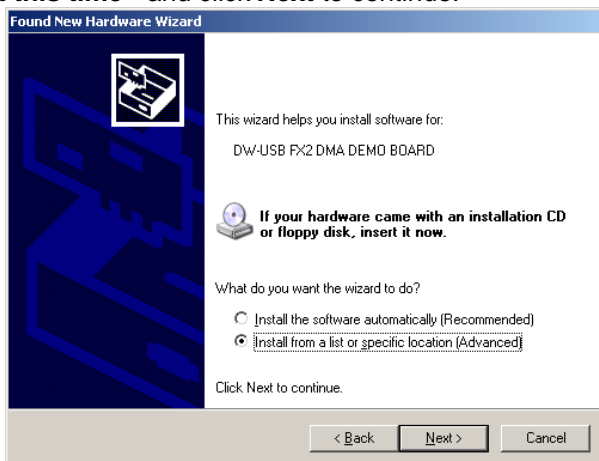

Select »**Install from a list or specific location (Advanced)**« option and click **Next**.

The driver should be located on the system CD. You can either point out this location or just simply select »**Search removable media**«.

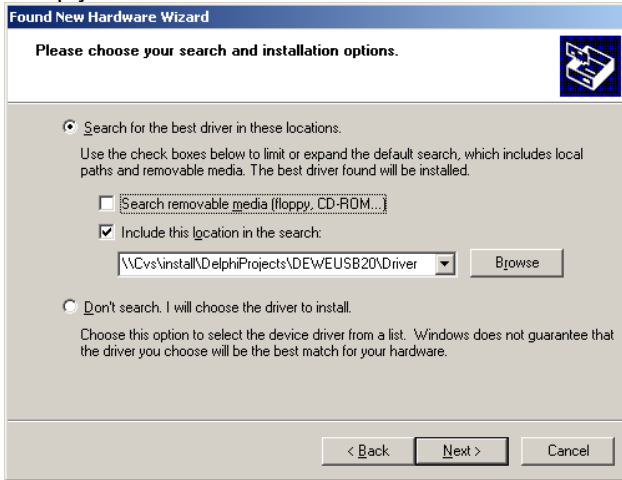

The installation procedure will install the driver.

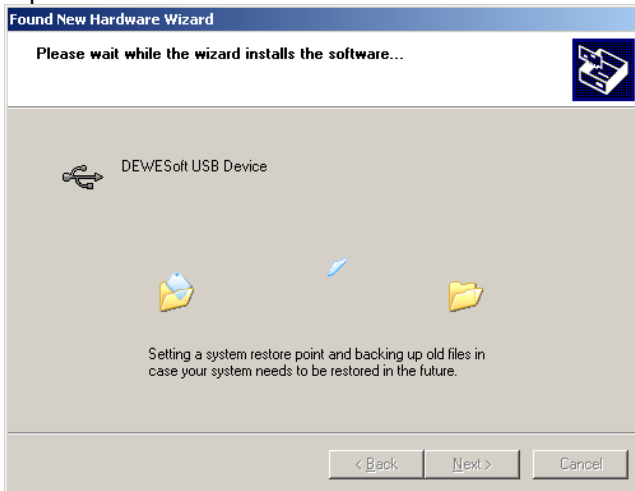

Finish the Wizard with **Finish** button.

6 Using DEWE 43 in Dewesoft

6.1 Before using the device

Please make sure that external power supply is connected before the device is connected via USB to the computer.

6.2 Hardware setup

To enable analog input and counter in Dewesoft, go to System – Hardware setup and choose Dewesoft USB device.

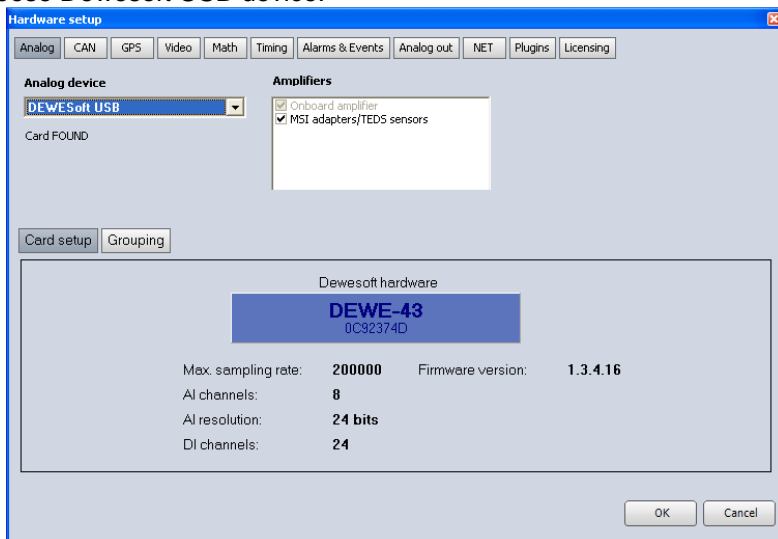

To enable CAN bus, please go to Can section and select Dewesoft USB device in CAN section. Make sure that the Hardware clock check box is enabled.

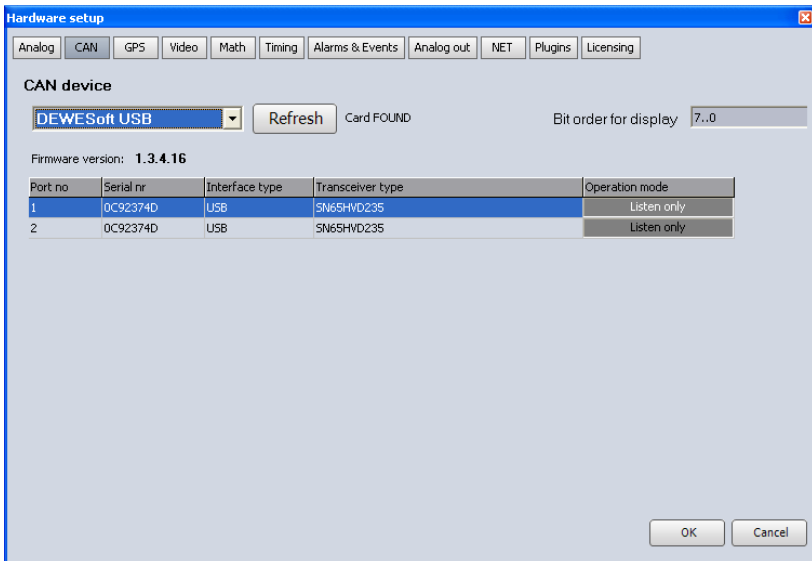

other cards are valid, but this registration comes with each system.

6.2.1 Start up of the device

Please connect the power supply of the device prior to connecting it to the USB. Then make sure that the device is connected to the PC when starting up Dewesoft. If the device is not connected, Dewesoft will open the Hardware setup screen and note that the device is missing.

DEWE-43

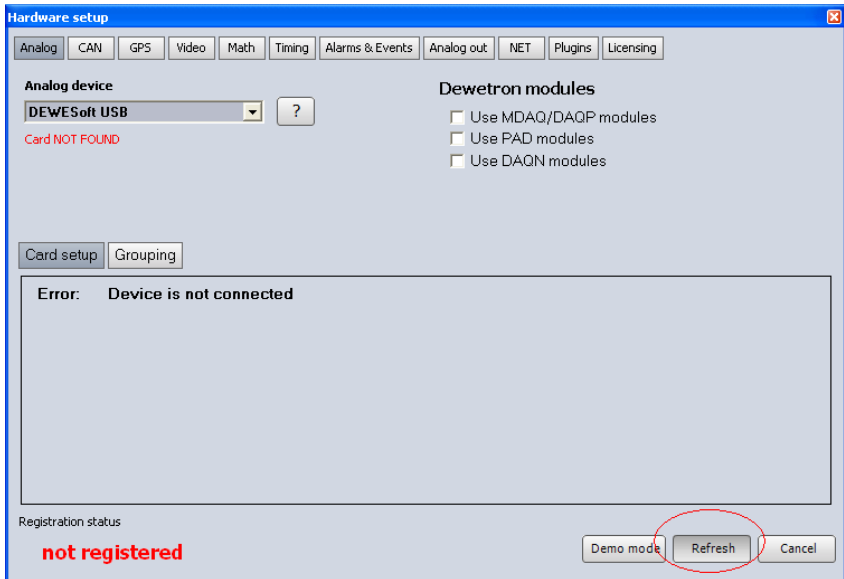

If you plan to simply review the files, please select “Demo mode”. If you plan to do a measurement, connect the device and click refresh button.

6.3 Using analog/counter/digital/CAN inputs

The use of analog inputs, CAN inputs and digital interface is the same as with all other DAQ devices, which are supported in Dewesoft. Please consult Dewesoft user's manual for more information.

If MSI adapters are used, they will be automatically recognized in the amplifier interface.

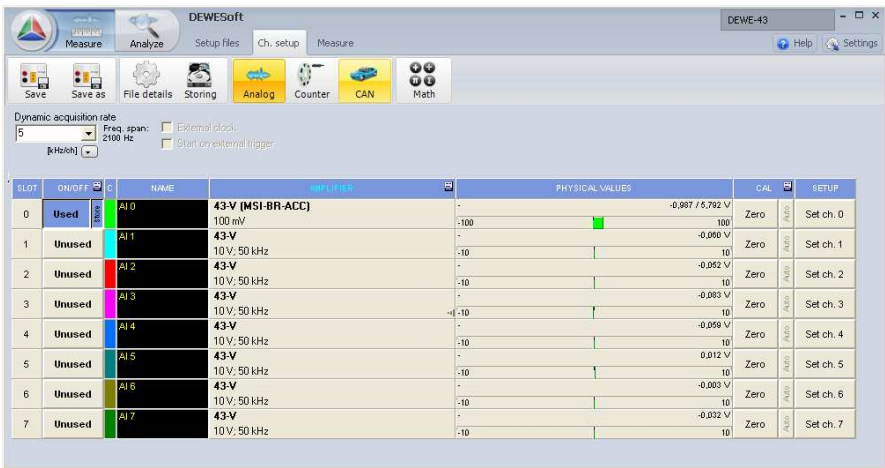

DEWE-43

When acquiring data and the USB connection is lost, the acquisition will stop. In this case reconnect the unit and restart the acquisition with reconnect button.

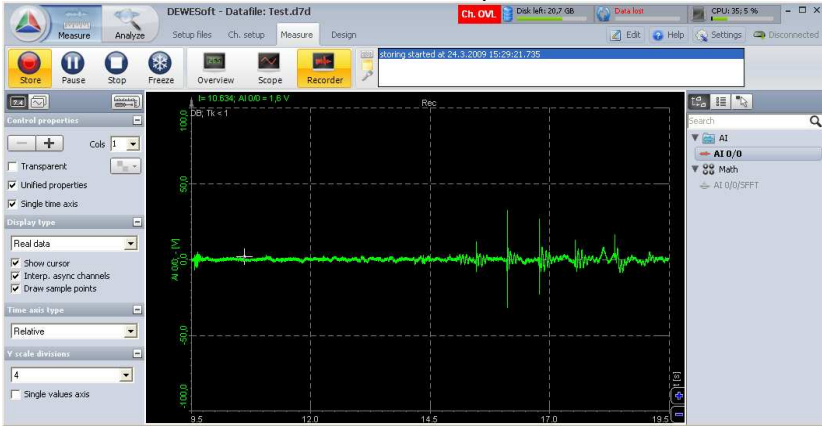

In this case (if the data was being stored, the gap will be filled in with missing data).

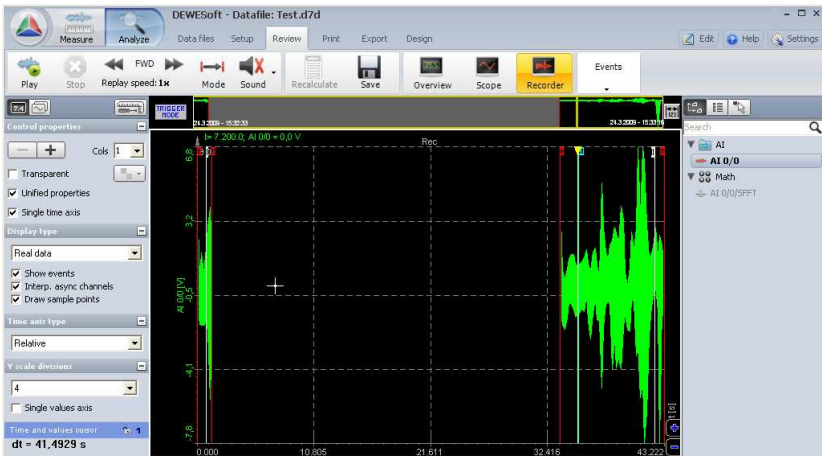

7 Firmware upgrade

To make firmware upgrade of the device, please connect DEWE43 with the USB cable to the computer. It is assumed that the drivers are already installed.

Important: Make sure that the external power supply is NOT connected during the firmware upgrade.

Please download the latest firmware from Dewesoft web site. Then run “USB Firmware Upgrade Tool” program.

Next select DEWEsoft USB in the “Device” combo box.

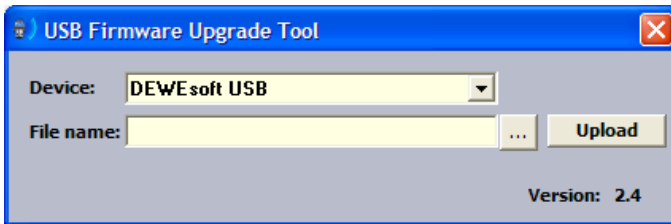

Press “...” button, select DEWE43_xxx.fwu file and click Open.

Press Upload button and wait until progress bar reaches 100%. Please don't interrupt this operation.

When upload is finished, press OK and new firmware is uploaded on the device. If this fails for any reason, repeat the upload process again.

When the process is finished, disconnect the USB, reconnect power and then reconnect USB again.

8 Dewesoft LICENSE INFORMATION

Dewesoft 6 LICENSE INFORMATION

To register your instrument in Dewesoft, please go to System – Hardware setup and follow the instruction from user's manual to select Dewesoft USB device in Analog and CAN tab sheet. If they are selected, deselect the DAQP/MDAQ amplifiers and go to licensing tab. Enter the license key 2187801 for A/D boards and 2187801 for the CAN device.

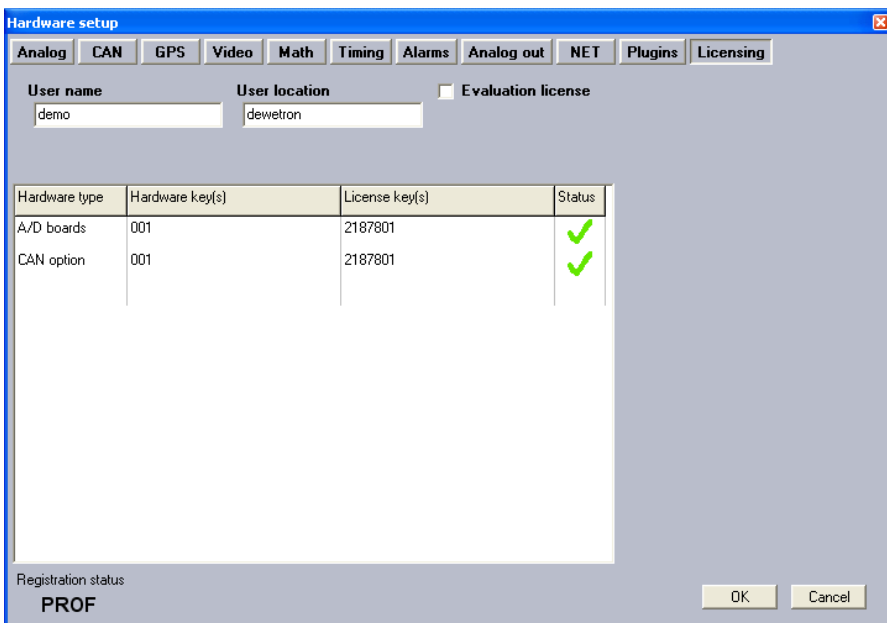

Dewesoft 7 LICENSE INFORMATION

Your Dewe 43 has many additional features which we will support with new releases of software. Dewesoft 7 enables the support of MSI adapters and digital inputs. With the purchase of Dewe 43 you are entitled for free upgrades of the software and firmware within all Dewesoft versions 6 and 7.

In Dewesoft 7, select the 43 like in version 6, go to registration, select Create and enter the license key provided in licence agreement:

The screenshot shows a Windows-style dialog box titled "Hardware setup" with a blue header and a close button (X) in the top right corner. Below the title bar is a menu bar with several options: Analog, CAN, GPS, Video, Math, Timing, Alarms & Events, Analog out, NET, Plugins, and Registration (which is highlighted in red). The main area of the dialog is divided into several sections. The first section has four columns: "User name" with a text box containing "Your name", "User location" with a text box containing "Your location", "Reference number (optional)" with an empty text box, and "Device number (optional)" with an empty text box. Below this is a section titled "Enter new license" with a text box containing the license key "DW7_KZ95_J9RC_2TM1" and three buttons: "Register online", "Register offline", and "Cancel". At the bottom left, there is a "Registration status" label with the text "not supported" in red. At the bottom right, there are "OK" and "Cancel" buttons.

Press Register Online (computer must be connected to Internet) and you will get the registration file.

DEWE-43

The screenshot shows a software window titled "Hardware setup" with a blue title bar and a close button. The "Registration" tab is selected, showing a series of tabs: Analog, CAN, GPS, Video, Math, Timing, Alarms & Events, Analog out, NET, Plugins, and Registration. Below the tabs are four input fields: "User name" (containing "Your name"), "User location" (containing "Your location"), "Reference number (optional)", and "Device number (optional)".

Below the input fields is a section titled "Existing license(s)" containing a table with the following data:

Used	License key	Software version and options	Status
✓	DW7-KZ95-J9RC-ZTM1	SE; Options:CAN	Valid

To the left of the table are three buttons: "Create", "Delete", and "Update". At the bottom left, the text "Registration status" is followed by "SE". At the bottom right are "OK" and "Cancel" buttons.