



Automotive  
Energy & Power Analysis  
Aerospace & Defense  
Transportation  
General Test & Measurement

# **DEWE-820-PFR**

*Technical reference manual*



Test & Measurement Solutions



Copyright © DEWETRON elektronische Messgeraete Ges.m.b.H.

This document contains information which is protected by copyright. All rights are reserved. Reproduction, adaptation, or translation without prior written permission is prohibited, except as allowed under the copyright laws.

All trademarks and registered trademarks are acknowledged to be the property of their owners.  
DEWESoft™ is a trademark of Dewesoft d.o.o

## Thank you!

Thank you very much for your investment in DEWETRON's unique data acquisition systems. These are top-quality instruments which are designed to provide you years of reliable service. This guide has been prepared to help you get the most from your investment, starting from the day you take it out of the box, and extending for years into the future.

This guide includes important startup notes, as well as safety notes and information about keeping your DEWETRON system in good working condition over time.

We strongly suggest that you read this entire manual, especially the safety and care sections, as well as to avoid damaging your DEWETRON system.

## What is the DEWE-820-PFR?

This product is used for measuring of different physical and/or electrical sizes (depending on model or configuration). The connection is depending on model or configuration and takes place via safety banana plugs, BNC connectors ( $\pm 50V$  max.), D-SUB connectors ( $\pm 50V$  max.), thermocouple connectors ( $\pm 50V$  max.), BINDER® connectors ( $\pm 50V$  max.), SMB connectors ( $\pm 50V$  max.),  $\mu$ dot connectors ( $\pm 50V$  max.), LEMO® connectors or RJ-45 connectors.

# Preface

---

Notes

## Content

<b>General Information, Safety Instructions</b>	<b>7</b>
Training .....	7
Calibration.....	7
Support .....	7
Service/repairs .....	7
Warranty Information .....	8
Printing History.....	8
Safety symbols in the manual .....	9
General safety and hazard warnings for all DEWETRON systems .....	10
Windows updates and antivirus/security software .....	13
Problematic network stacks .....	13
Environmental Considerations .....	13
Blockdiagram of the internal signal processing .....	14
First steps .....	15
<b>Main System</b>	<b>17</b>
DEWE-PFR-820 - Application specific product .....	17
System specifications .....	17
Cleaning the filter pad.....	18
Connectors .....	18
HSI series modules overview .....	22
DAQ series modules overview .....	23
Power supply .....	25
<b>Software</b>	<b>27</b>
<b>A/D Conversion</b>	<b>A1</b>
<b>Internal Wiring</b>	<b>B1</b>
<b>CE-Certificate of conformity</b>	<b>C1</b>

# Table of content

---

## Training

DEWETRON offers training at various offices around the world several times each year. DEWETRON headquarters in Austria have a very large and professional conference and seminar center, where training classes are conducted on a regular basis starting with sensors and signal conditioning, A/D technology and software operation. For more information about training services, please visit:  
<http://www.dewetron.com/support/training>

Dewetron Inc. in the USA also has a dedicated training facility connected to its headquarters, located in Rhode Island. For more information about training services in the US, please visit:  
<http://www.dewamerica.com/support/training>

## Calibration

Every instrument needs to be calibrated at regular intervals. The standard norm across nearly every industry is annual calibration. Before your DEWETRON data acquisition system is delivered, it is calibrated at our DEWETRON headquarter. Each of this system is delivered with a certificate of compliance with our published specifications. Detailed calibration reports from our calibration system are available for purchase with each order. We retain them for at least one year, so calibration reports can be purchased for up to one year after your system was delivered.

## Support

DEWETRON has a team of people ready to assist you if you have any questions or any technical difficulties regarding the system. For any support please contact your local distributor first or DEWETRON directly.

For Asia and Europe, please contact:

DEWETRON Ges.m.b.H.  
Parkring 4  
A-8074 Graz-Grambach  
AUSTRIA  
Tel.: +43 316 3070  
Fax: +43 316 307090  
Email: [support@dewetron.com](mailto:support@dewetron.com)  
Web: <http://www.dewetron.com>

The telephone hotline is available  
Monday to Friday between  
08:00 and 17:00 CET (GMT +1:00)

## Service/repairs

The Team of DEWETRON also performs any kinds of repairs to your system to assure a safe and proper operation in future. For information regarding service and repairs please contact your local distributor first or DEWETRON directly.

For the Americas, please contact:

DEWETRON, Inc.  
10 High Street, Suite K  
Wakefield, RI 02879  
U.S.A.  
Tel.: +1 401 284 3750  
Toll-free: +1 877 431 5166  
Fax: +1 401 284 3755  
Email: [support@dewamerica.com](mailto:support@dewamerica.com)  
Web: <http://www.dewamerica.com>

The telephone hotline is available  
Monday to Friday between  
08:00 and 17:00 GST (GMT -5:00)

# Notice

---

The information contained in this document is subject to change without notice.

DEWETRON elektronische Messgeraete Ges.m.b.H. (DEWETRON) shall not be liable for any errors contained in this document. DEWETRON MAKES NO WARRANTIES OF ANY KIND WITH REGARD TO THIS DOCUMENT, WHETHER EXPRESS OR IMPLIED. DEWETRON SPECIFICALLY DISCLAIMS THE IMPLIED WARRANTIES OF MERCHANTABILITY AND FITNESS FOR A PARTICULAR PURPOSE. DEWETRON shall not be liable for any direct, indirect, special, incidental, or consequential damages, whether based on contract, tort, or any other legal theory, in connection with the furnishing of this document or the use of the information in this document.

## Warranty Information

A copy of the specific warranty terms applicable to your DEWETRON product and replacement parts can be obtained from your local sales and service office.

## Restricted Rights Legend

Use austrian law for duplication or disclosure.

DEWETRON GesmbH  
Parkring 4  
A-8074 Graz-Grambach / Austria

## Printing History

Please refer to the page bottom for printing version.

Copyright © DEWETRON elektronische Messgeraete Ges.m.b.H.

This document contains information which is protected by copyright. All rights are reserved. Reproduction, adaptation, or translation without prior written permission is prohibited, except as allowed under the copyright laws.

All trademarks and registered trademarks are acknowledged to be the property of their owners.

# Safety instructions

---

## Safety symbols in the manual

---



*Indicates hazardous voltages.*

---

**WARNING** *Calls attention to a procedure, practice, or condition that could cause bodily injury or death.*

---

**CAUTION** *Calls attention to a procedure, practice, or condition that could possibly cause damage to equipment or permanent loss of data.*

---

### **WARNINGS**

*The following general safety precautions must be observed during all phases of operation, service, and repair of this product. Failure to comply with these precautions or with specific warnings elsewhere in this manual violates safety standards of design, manufacture, and intended use of the product. DEWETRON Elektronische Messgeraete Ges.m.b.H. assumes no liability for the customer's failure to comply with these requirements.*

---

**All accessories shown in this document are available as option and will not be shipped as standard parts.**



*For safety reasons max. 50 V may be applied to the BNC input-connectors!  
Refer to the regulation of maximum allowable touch potential.*

---

# Safety instructions

---

**Your safety is our primary concern! Please be safe!**

## **General safety and hazard warnings for all DEWETRON systems**

- Use this system under the terms of the specifications only to avoid any possible danger.
- Maintenance will be executed by qualified staff only.
- During the use of the system, it might be possible to access another parts of a more comprehensive system. Please read and follow the safety instructions provided in the manuals of all other components regarding warning and security advices for using the system.
- With this product, only use the power cable delivered or defined for the host country.
- DO NOT connect or disconnect sensors, probes or test leads, as these parts are connected to a voltage supply unit.
- The system is grounded via a protective conductor in the power supply cord. To avoid electric shocks, the protective conductor has to be connected with the ground of the power network. Before connecting the input or output connectors of the system, make sure that there is a proper grounding to guarantee potential free usage. For countries, in which there is no proper grounding, please refer to your local legally safety regulations for safety use.  
  
DC systems: Every DC system has a grounding connected to the chassis (yellow/green safety banana plug).
- Please note the characteristics and indicators on the system to avoid fire or electric shocks. Before connecting the system, please carefully read the corresponding specifications in the product manual.
- The inputs are not, unless otherwise noted (CATx identification), for connecting to the main circuit of category II, III and IV.
- The power cord separates the system from the power supply. Do not block the power cord, since it has to be accessible for the users.
- DO NOT use the system if equipment covers or shields are removed.
- If you assume the system is damaged, get it examined by authorised personnel only.
- Any use in wet rooms, outdoors or in adverse environmental condition is not allowed!  
Adverse environmental conditions are:
  - Moisture or high humidity
  - Dust, flammable gases, fumes or dissolver
  - Thunderstorm or thunderstorm conditions (except assembly PNA)
  - Electrostatic fields, et cetera.
- The measurement category can be adjusted depending on module configuration.
- Any direct voltage output is protected with a fuse against short cut and reverse-polarity, but is NOT galvanically isolated (except it is explicit marked on the system).
- The system must be connected and operated to an earthed wall socket at the AC mains power supply only (except for DC systems).
- Any other use than described above may damage your system and is attended with dangers like shortcut, fire or electric shocks.
- The whole system must not be changed, rebuilt or opened (except for changing DAQ, DAQP, PAD modules).

# Safety instructions

- If you assume a more riskless use is not provided anymore, the system has to be rendered inoperative and should be protected against inadvertent operation. It is assumed that a more riskless operation is not possible anymore, if
    - the system is damaged obviously or causes strange noises.
    - the system does not work anymore.
    - the system has been exposed to long storage in adverse environmental.
    - the system has been exposed to heavy shipment strain.
  - DO NOT touch any exposed connectors or components if they are live wired. The use of metal bare wires is not allowed. There is a risk of short cut and fire hazard!
  - Warranty void if damages caused by disregarding this manual. For consequential damages NO liability will be assumed!
  - Warranty void if damages to property or persons caused by improper use or disregarding the safety instructions.
  - Unauthorized changing or rebuilding the system is prohibited due to safety and permission reasons (CE). Exception: changing modules like DAQ, DAQP or PAD.
  - The assembly of the system is equivalent to protection class I. For power supply, only the correct power socket of the public power supply must be used, except the system is DC powered.
  - Be careful with voltages >25 VAC or >35 VDC! These voltages are already high enough in order to get a perilous electric shock by touching the wiring.
  - The product heats during operation. Make sure there is adequate ventilation. Ventilation slots must not be covered!
  - Only fuses of the specified type and nominal current may be used. The use of patched fuses is prohibited.
  - Prevent using metal bare wires! Risk of short cut and fire hazard!
  - DO NOT use the system before, during or shortly after a thunderstorm (risk of lightning and high energy overvoltage). An advanced range of application under certain conditions is allowed with therefore designed products only. For details please refer to the specifications.
  - Make sure that your hands, shoes, clothes, the floor, the system or measuring leads, integrated circuits and so on, are dry.
  - DO NOT use the system in rooms with flammable gases, fumes or dust or in adverse environmental conditions.
  - Avoid operation in the immediate vicinity of:
    - high magnetic or electromagnetic fields
    - transmitting antennas or high-frequency generators
- For exact values please refer to enclosed specifications.
- Use measurement leads or measurement accessories aligned to the specification of the system only. Fire hazard in case of overload!
  - Do not switch on the system after transporting it from a cold into a warm room and vice versa. The thereby created condensation may damage your system. Acclimatise the system unpowered to room temperature.
  - Do not disassemble the system! There is a high risk of getting a perilous electric shock. Capacitors still might be charged, even the system has been removed from the power supply.
  - The electrical installations and equipments in industrial facilities must be observed by the security regulations and insurance institutions.

# Safety instructions

---

- The use of the measuring system in schools and other training facilities must be observed by skilled personnel.
- The measuring systems are not designed for use at humans and animals.
- Please contact a professional if you have doubts about the method of operation, safety or the connection of the system.
- Please be careful with the product. Shocks, hits and dropping it from already lower level may damage your system. For exact values please refer to enclosed specifications.
- Please also consider the detailed technical reference manual as well as the security advices of the connected systems.

This product has left the factory in safety-related flawless and proper condition.

In order to maintain this condition and guarantee safety use, the user has to consider the security advices and warnings in this manual.

EN 61326-3-1:2008

IEC 61326-1 applies to this part of IEC 61326 but is limited to systems and equipment for industrial applications intended to perform safety functions as defined in IEC 61508 with SIL 1-3.

The electromagnetic environments encompassed by this product family standard are industrial, both indoor and outdoor, as described for industrial locations in IEC 61000-6-2 or defined in 3.7 of IEC 61326-1. Equipment and systems intended for use in other electromagnetic environments, for example, in the process industry or in environments with potentially explosive atmospheres, are excluded from the scope of this product family standard, IEC 61326-3-1.

Devices and systems according to IEC 61508 or IEC 61511 which are considered as “operationally well-tried”, are excluded from the scope of IEC 61326-3-1.

Fire-alarm and safety-alarm systems, intended for protection of buildings, are excluded from the scope of IEC 61326-3-1.

## **CAUTION**

- The system BIOS is protected by password. Any change in the BIOS may cause a system crash. When the system is booting, do not press ESC-button on keyboard. This may clear the BIOS settings and cause system faults.
- Any change in the file structure as deleting or adding files or directories might cause a system crash.
- Before installing software updates contact DEWETRON or your local distributor. Use only software packages which are released by DEWETRON. Further informations are also available in the internet (<http://www.dewetron.com>).
- After power off the system wait at least 10 seconds before switching the system on again. Otherwise the system may not boot correct. This prolongs also the life of all system components.

## **Windows updates and antivirus/security software**

Before installing Windows software updates consult with DEWETRON for compatibility guidance. Please also keep in mind that the use of any antivirus or other security software may slow down your system and may cause data loss.

## **Problematic network stacks**

Often intrusive IT software or network processes can interfere with the primary function of the DEWETRON system: to record data. Therefore we recommend strongly against the installation of IT/MIS software and running their processes on any DEWETRON data acquisition system, and cannot guarantee the performance of our systems if they are so configured.



## **Environmental Considerations**

Information about the environmental impact of the product.

## **Product End-of-Life Handling**

Observe the following guidelines when recycling a DEWETRON system:



## **System and Components Recycling**

Production of these components required the extraction and use of natural resources. The substances contained in the system could be harmful to your health and to the environment if the system is improperly handled at its end of life! Please recycle this product in an appropriate way to avoid an unnecessary pollution of the environment and to keep natural resources.

This symbol indicates that this system complies with the European Union's requirements according to Directive 2002/96/EC on waste electrical and electronic equipment (WEEE). Please find further informations about recycling on the DEWETRON web site [www.dewetron.com](http://www.dewetron.com)

## **Restriction of Hazardous Substances**

This product has been classified as Monitoring and Control equipment, and is outside the scope of the 2002/95/EC RoHS Directive. This product is known to contain lead.

# Signal processing

## Blockdiagram of the internal signal processing

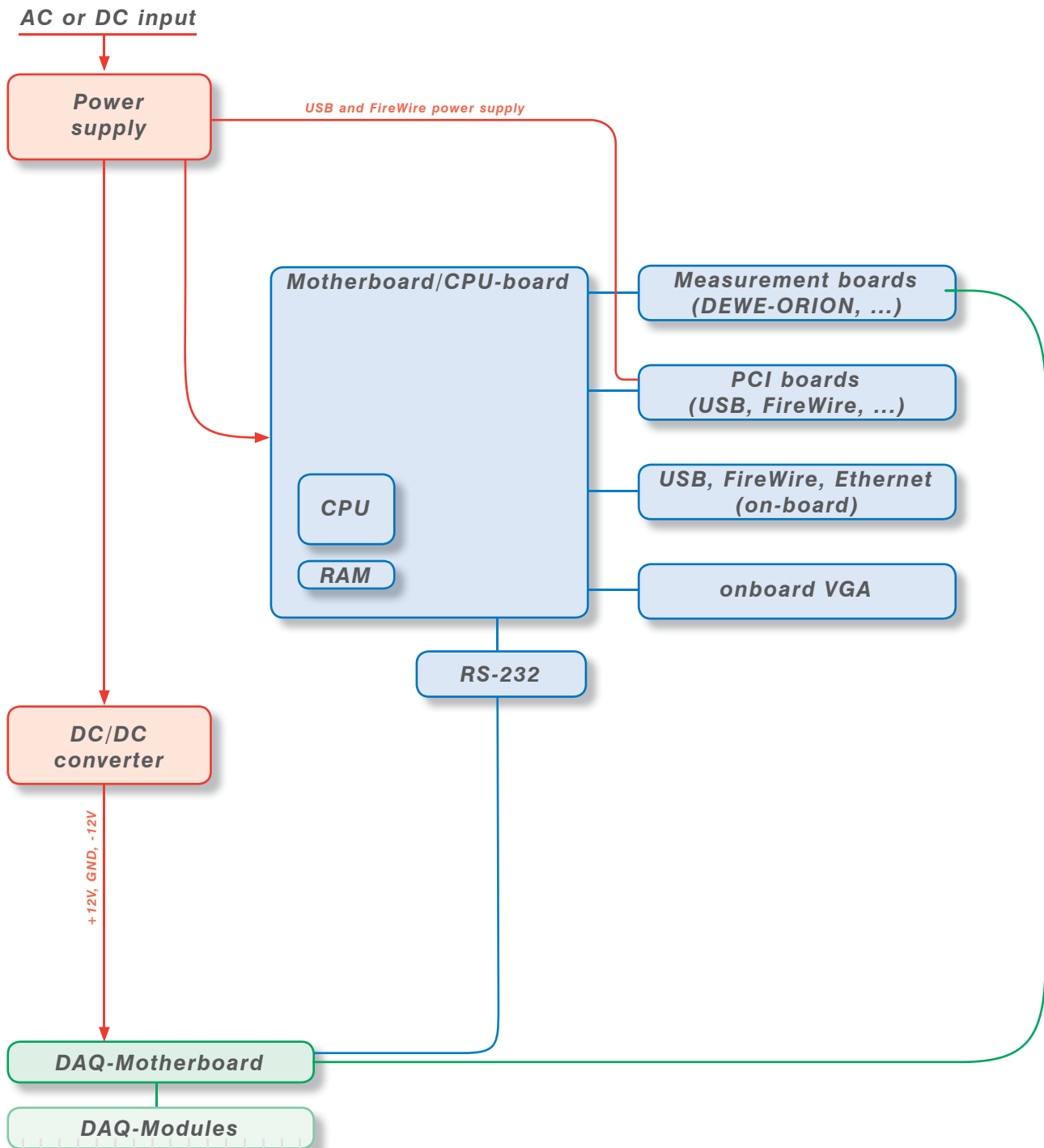

## First steps

1



Power-on your system.

2

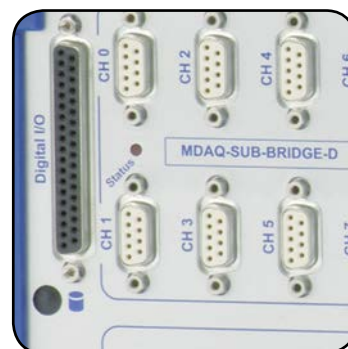

Connect your sensors to the system.

3

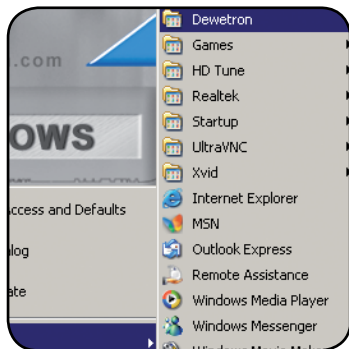

Run DEWESoft usually via "Start" > "Programs" > "Dewetron" > "DEWESoft x.x" > "DEWESoft x.x"

4

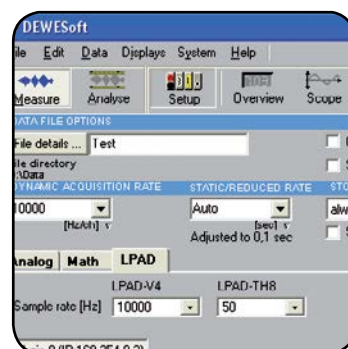

Start recording your data!

# First steps

---

Notes

## DEWE-PFR-820 - Application specific product

- Monitoring of power supply systems
- Fault recording
- Harmonics, Flicker
- IEC 61000 conform
- GPS synchronisation
- A/D converter specs see appendix A



## System specifications

PFR-820	
Input amplifier	DAQP module series (for details see DEWE-Modules manual)
Power supply:	<input checked="" type="checkbox"/> 400 W AC ATX power supply BEA-640 <input checked="" type="checkbox"/> 300 W DC ATX power supply DX 300HEW <input checked="" type="checkbox"/> 300 W DC ATX power supply APT-DY300H For details see next pages.
Operating temperature:	-5 °C to 50 °C (standard)
Storage temperature:	-20 °C to +70 °C
Humidity (operating):	10 % to 80 %, non condensing 5 % to 95 %, rel. humidity
Dimensions (W x D x H):	approx. 437 x 443 x 177 mm (17.2 x 17.4 x 7 in.)
Weight:	typ. 15 kg (33 lbs), depending on configuration

## Dimensions\*

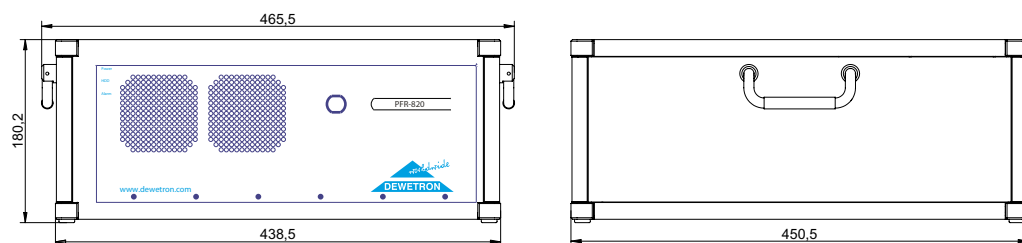

\* Dimensions in mm  
(1 inch = 25.4 mm)

# Main System

## Cleaning the filter pad

*Note: Check the filter pad frequently! A polluted filter pad may cause an overheating of the system! The cleaning interval depends on the environmental conditions.*

To clean or exchange the filter pad you only have to open the front cover and pull out the filter-drawer.



*Filter-drawer with filter pad*

## Connectors



10 3 2 6 5 7 8 4

*Typical PFR-820 front view*

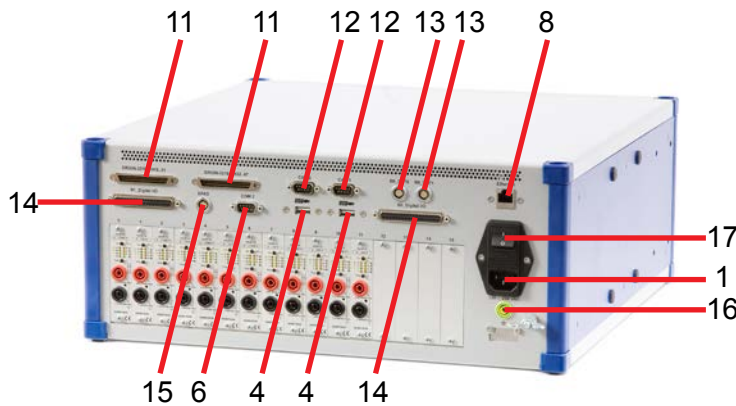

15 6 4 4 14

*Typical PFR-820 rear view*

Connector overview:

1. Power supply input connector
2. PS/2 keyboard connector
3. PS/2 mouse connector
4. USB interface connectors
5. LPT interface connector
6. RS-232 interface connector
7. VGA connector
8. Ethernet LAN connector
9. IEEE-1394 (FireWire®) connector
10. Power-on switch
11. **ORION expansion connector (optional)**
12. **CAN interface connector (optional)**
13. **Counter inputs (optional)**
14. **Digital I/O connector (optional)**
15. **EPAD interface connector**
16. Ground connector
17. Main power switch

*Note: The location of the connectors might vary from system to system and depends on system configuration*

## 1 Power supply input connector

For details see chapter power supply.

## 2 PS/2 mouse connector

The mouse / trackball connector is used to connect the trackball embedded in the keyboard or an external PS/2 mouse. The connector meets standard PS/2 pin assignment.

## 3 PS/2 keyboard connector

The keyboard connector is used to connect PS/2 keyboard to PFR-820 system. The connector meets standard PS/2 pin assignment.

## 4 USB interface connectors (Universal Serial Bus)

The USB interface connectors meets standard USB pin assignment.

## 5 LPT printer interface connector

The printer interface connector (female) is located on the front side of the PFR-820. It is configured as standard LPT interface. The printer interface connector meets standard LPT pin assignment.

## 6 RS-232 interface connector (COM 1 & optional COM 2)

The RS-232 interface connector (male) is located on the front side of the DEWE-PFR-820. It is configured as standard RS-232 interface COM 1 and can be used for mouse or other peripheral units. Optionally the COM 2 interface connector (female) is located on the rear side of the DEWE-PFR-820 and meets standard RS-232 pin assignment.

## 7 VGA connector

The VGA connector offers the possibility to connect a CRT or other standard VGA displays to the system. This VGA connector meets standard VGA pin assignment.

## 8 Ethernet connector

The PFR-820 system supports 10/100 BaseT Ethernet with standard RJ45 connector.

## 9 IEEE-1394 (FireWire®) connector

The FireWire® interface connector meets standard FireWire® pin assignment.

## 10 Power-on switch

The power-on button has to be used to switch on the system. It only works when the main power switch is on.

## WATCHDOG (optional)

The WATCHDOG card is used for function monitoring on a PC. If a running software is causing problems and the PC can't handle it resulting in a crash, the WATCHDOG interface switches one or two relays in order to restart the PC or shut down an external modem. Pinning of this 9-pin male SUB-D connector:

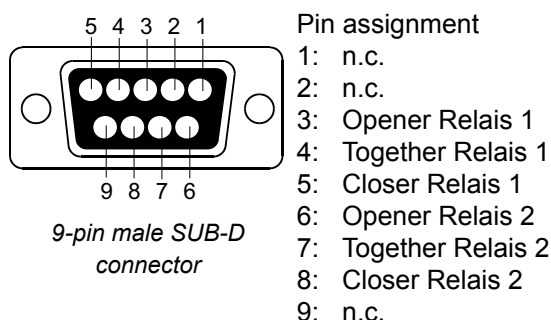

# Main System

## 11 Expansion interface connector (in conjunction with DEWE-ORION-xxxx boards)

The ORION expansion interface connector is installed in case the system is equipped with a 32 channel ORION card or a ORION card with counter expansion.

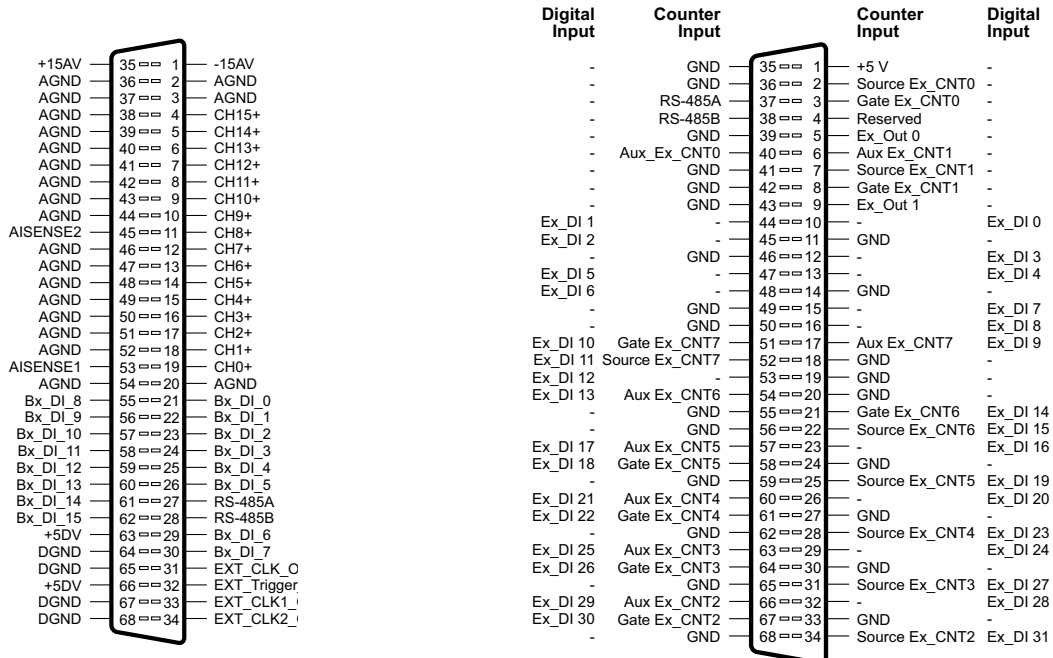

ORION card with 32 analog inputs  
(ORION-3216-10x, ORION-3222-10x)

68-pin Amplimite series  
(AMP: 174339-5) SCSI II

ORION card with counter expansion  
(ORION-xxxx-x02, -x03, -x04, -x05)

68-pin Amplimite series  
(AMP: 174339-5) SCSI II



**Note:** Only available for standard systems using ORION-xxxx cards!

## 12 CAN connector (optional)

This connector supports the CAN signals of the built-in A/D board. If this board does not support CAN signals, the connector is not available.

### CAN 0:

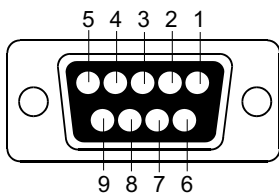

Pin assignment

- 1: +5 V
- 2: CAN0\_L
- 3: GND
- 4: n.c.
- 5: n.c.
- 6: GND
- 7: CAN0\_H
- 8: n.c.
- 9: +12 V

### CAN 1:

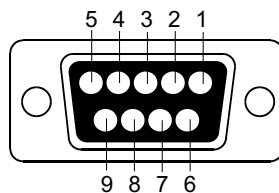

Pin assignment

- 1: +5 V
- 2: CAN1\_L
- 3: GND
- 4: n.c.
- 5: n.c.
- 6: GND
- 7: CAN1\_H
- 8: n.c.
- 9: +12 V

## 13 Optional counter inputs (in conjunction with DEWE-ORION-xxxx boards)

- 1: Source Bx\_CNT(n)
  - 2: Aux\_Bx\_CNT(n)
  - 3: Gate Bx\_CNT(n)
  - 4: Power GND
  - 5: +5 V (max. 500 mA)
  - 6: +12 V (max. 500 mA)
  - 7: Signal GND
- n .. channels 0 to 1 of counter board

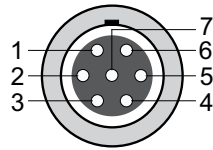

7-pin female LEMO connector  
EGG.1B.307

Mating connector:  
LEMO FGG.1B.307.CLAD52Z  
(for cable diameter 4.1 to 5.0 mm)  
LEMO FGG.1B.307.CLAD62Z  
(for cable diameter 5.1 to 6.0 mm)

Cable to open end, 5 m long:  
CTR-CBL-05

## 14 Digital I/O connector (optional)

This connector supports digital input and output lines of the built-in DEWE-ORION series board. If this board does not support digital I/O's, the connector is not available.

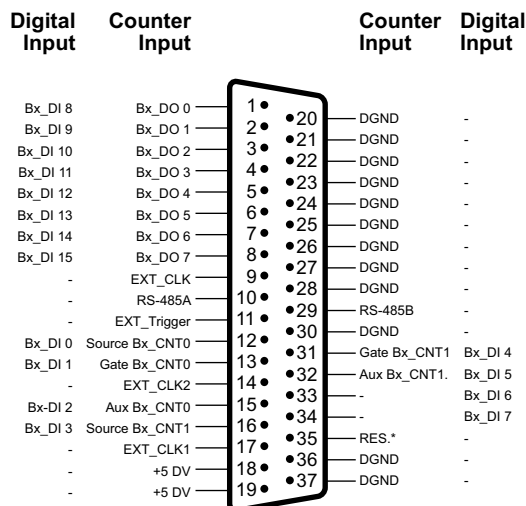

37-pin SUB-D connector



*Note: Only available for standard systems using ORION-xxxx cards!*

## 15 EPAD connector (LEMO)

To connect DEWETRON EPAD modules to the system.

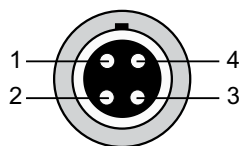

Lemo EGG.1B.304

Pin assignment

- 1: RS-485 A
- 2: RS-485 B
- 3: +12 V
- 4: GND

Shield is connected on housing

Mating connector: LEMO FGG.1B.304.CLAD52Z (for cable diameter 4.1 to 5.0 mm)  
LEMO FGG.1B.304.CLAD62Z (for cable diameter 5.1 to 6.0 mm)

## 16 Ground connector

For some kind of measurements, it's necessary to give the system an additional ground connection.

# Main System

## Optional connector for current power probe supply

This connector supports  $\pm 9\text{ V}$  /  $\pm 15\text{ V}$  current power probe supply for connecting current clamps.

### 6-pin male/female Lemo connector (with digital inputs of ORION board)

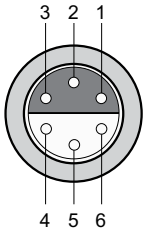











Pin assignment

- 1: +15 V
- 2: -15 V
- 3: +9 V
- 4: DGND
- 5: DI(x)
- 6: DGND

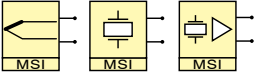





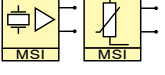

Lemo EGG.1B.306

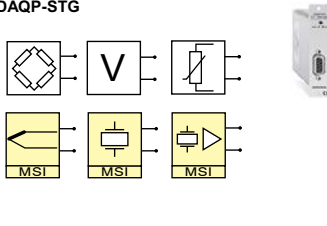
x .. digital inputs 0..7 of the ORION board

## HSI series modules overview

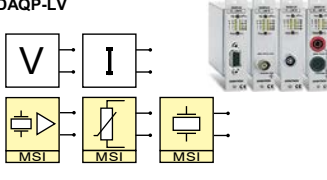



Module	Input type	Ranges	TEDS	Bandwidth (BW), Filters (LP = lowpass, HP = highpass)	Isolation (ISO), Overvoltage protection (OP)
<b>Universal measurement</b>					
<b>HSI-STG</b>	    	Strain gauge, bridge sensors Piezoresistive bridge Voltage Resistance Pt100, Pt200, Pt500, Pt1000, Pt2000 IEPe <sup>®</sup> via MSI-BR-ACC Thermocouple via MSI-BR-TH-x Charge via MSI-BR-CH-50 Voltage via MSI-BR-V-200	$\pm 0.1$ to $\pm 1000$ mV/V (@ 5 VDC <sub>exc.</sub> ) $\pm 0.5$ to 10000 mV/mA (@ 1 mA <sub>exc.</sub> ) $\pm 500$ $\mu$ V to $\pm 10$ V 25 m $\Omega$ to 100 k $\Omega$ -200° C to 850° C $\pm 100$ to $\pm 10000$ mV full range of TC type up to 50000 pC up to $\pm 200$ V	✓ BW: up to 2 MHz LP: 100 Hz to 2 MHz	ISO: 350 V <sub>DC</sub> OP: $\pm 50$ V <sub>DC</sub>
<b>High voltage measurement</b>					
<b>HSI-HV</b>	 	High voltage	$\pm 20$ to $\pm 1400$ V	- BW: 2 MHz LP: 100 Hz to 2 MHz	ISO: 1.8 kV <sub>RMS</sub>
<b>Voltage &amp; current measurement</b>					
<b>HSI-LV</b>	   	Voltage Current with external shunt IEPe <sup>®</sup> via MSI-V-ACC Pt100, Pt200, Pt500, Pt1000, Pt2000 and resistance via MSI-V-RTD	$\pm 10$ mV to $\pm 50$ V 20 mA / 5 A $\pm 10$ mV to 5 V -200° C to 1000° C and 8 to 4 k $\Omega$	✓ BW: 2 MHz LP: 100 Hz to 2 MHz	ISO: up to 1 kV <sub>RMS</sub> OP: 350 V <sub>DC</sub>

## DAQ series modules overview

Module	Input type	Ranges	TEDS	Bandwidth (BW), Filters (LP = lowpass, HP = highpass)	Isolation (ISO), Overvoltage protection (OP)
<b>Universal measurement</b>					
<b>DAQP-STG</b> 	Strain gauge, bridge sensors	$\pm 0.1$ to $\pm 1000$ mV/V (@ 5 VDC <sub>exc</sub> )	■	BW: 300 kHz LP: 10 Hz to 300 kHz	ISO: 350 V <sub>DC</sub> OP: $\pm 50$ V <sub>DC</sub>
	Piezoresistive bridge	$\pm 0.5$ to 10000 mV/mA (@ 1 mA <sub>exc</sub> )			
	Voltage	$\pm 500$ $\mu$ V to $\pm 10$ V			
	Resistance	25 m $\Omega$ to 100 k $\Omega$			
	Pt100, Pt200, Pt500, Pt1000, Pt2000	-200° C to 850° C			
	IEPE® via MSI-BR-ACC	$\pm 2.5$ to $\pm 10000$ mV			
	Thermocouple via MSI-BR-TH-x	full range of TC type			
Charge via MSI-BR-CH-50	up to 50000 pC				
Voltage via MSI-BR-V-200	up to $\pm 200$ V				
<b>High voltage measurement</b>					
<b>DAQP-HV</b> 	High voltage	$\pm 20$ to $\pm 1400$ V	-	BW: 300 kHz LP: 10 Hz to 300 kHz	ISO: 1.8 kV <sub>RMS</sub>
<b>DAQP-HV-S3</b> 	High voltage	$\pm 20$ to $\pm 1400$ V	-	BW: 700 kHz LP: 10 Hz to 700 kHz	ISO: 1.8 kV <sub>RMS</sub>
<b>DAQP-DMM</b> 	High voltage	$\pm 10$ to $\pm 1000$ V	-	BW: 20/30 kHz LP: 10 Hz to 30 kHz	ISO: 1.5 kV <sub>RMS</sub>
<b>Voltage &amp; current measurement</b>					
<b>DAQP-LV</b> 	Voltage	$\pm 10$ mV to $\pm 50$ V	■	BW: 300 kHz LP: 10 Hz to 300 kHz	ISO: up to 1 kV <sub>RMS</sub> OP: 350 V <sub>DC</sub>
	Current with external shunt	20 mA / 5 A			
	IEPE® via MSI-V-ACC	$\pm 10$ mV to 10 V			
	Pt100, Pt200, Pt500, Pt1000, Pt2000 and resistance via MSI-V-RTD	-200° C to 1000° C and 0 to 6.5 k $\Omega$ m			
Charge via MSI-V-CH-50	up to 50000 pC				
<b>DAQP-V</b> 	Voltage	10 mV to 50 V	-	BW: 50 kHz LP: 10 Hz to 50 kHz	ISO: up to 1 kV <sub>RMS</sub> OP: $\pm 500$ V <sub>DC</sub>
	Current with external shunt	20 mA / 5 A			
<b>DAQN-AIN</b> 	Voltage	$\pm 10$ V (1:1 input)	-	-	OP: < $\pm 500$ V (jumper selectable)
<b>Current measurement</b>					
<b>DAQP-LA-SC</b> 	Current Note: 5 A <sub>RMS</sub> continuous	0.1 A to 30 A peak max. 5 A <sub>RMS</sub> contin. current	-	BW: 300 kHz LP: 10 Hz to 300 kHz	ISO: 1.4 kV <sub>RMS</sub>
<b>DAQP-LA-B</b> 	Current Note: typ. 20 mA application	2 mA to 600 mA	-	BW: 300 kHz LP: 10 Hz to 300 kHz	ISO: 1.4 kV <sub>RMS</sub>

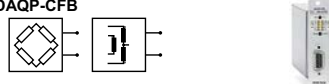
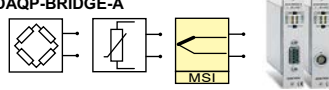
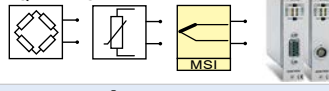
■ = standard

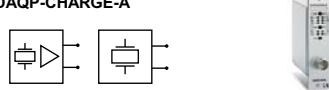
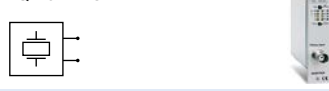
# Main System

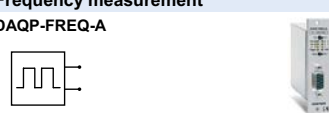
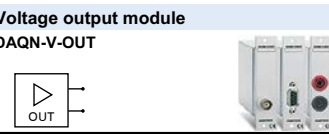
Module	Input type	Ranges	TEDS	Bandwidth (BW), Filters (LP = lowpass, HP = highpass)	Isolation (ISO), Overvoltage protection (OP)
<b>Bridge / strain gauge and carrier frequency amplifier</b>					
<b>DAQP-CFB</b> 	AC bridge, strain gauge <i>Note: 5 kHz sine wave excitation</i> Inductive sensors, LVDT	Bridge: 0.1 to 1000 mV/V Inductive: 5 to 1000 mV/V	-	BW: DC to 2.3 kHz LP: 10 Hz to 1 kHz	OP: $\pm 10 V_{DC}$
<b>DAQP-BRIDGE-A</b> 	Strain gauge, bridge sensors Potentiometric sensors	$\pm 1$ to $\pm 50$ mV/V (@ 5 VDC) 200 $\Omega$ to 10 k $\Omega$	-	BW: 20 kHz LP: 10 Hz to 20 kHz	ISO: 350 V <sub>DC</sub> OP: $\pm 10 V_{DC}$
<b>DAQP-BRIDGE-B</b> 	Strain gauge, bridge sensors Potentiometric sensors	$\pm 0.1$ to $\pm 100$ mV/V (@ 5 VDC) 200 $\Omega$ to 10 k $\Omega$	■ <sup>1)</sup>	BW: 200 kHz LP: 10 Hz to 200 kHz	OP: $\pm 10 V_{DC}$
<b>Charge / IEPE<sup>®</sup> measurement</b>					
<b>DAQP-ACC-A</b> 	IEPE <sup>®</sup> sensors	$\pm 50$ mV to $\pm 5$ V	-	BW: 0.5 Hz to 300 kHz LP: 1 to 300 kHz HP: 0.5 Hz and 5 Hz	-
<b>DAQP-CHARGE-A</b> 	Charge sensors IEPE <sup>®</sup> sensors <i>Note: selectable integration and double integration</i>	Charge: 5 to 50000 pC IEPE <sup>®</sup> : $\pm 5$ mV to 5 V	-	BW: 0.1 Hz to 50 kHz LP: 100 Hz to 50 kHz HP: 0.1 Hz to 10 Hz	-
<b>DAQP-CHARGE-B</b> 	Charge sensors <i>Note: selectable time constant for static sensors</i>	$\pm 100$ to $\pm 1\,000\,000$ pC	-	BW: DC to 100 kHz LP: 10 Hz to 100 kHz HP: DC, 0.001 Hz to 0.5 Hz	ISO: 350 V <sub>DC</sub>
<b>Temperature measurement</b>					
<b>DAQN-THERM-x</b> 	Thermocouple <i>Note: internal CJC</i>	K and J type (others on request) DAQN-THERM-1 K: -30 to 170 °C DAQN-THERM-2 K: -30 to 370 °C DAQN-THERM-3 K: 0 to 1000 °C DAQN-THERM-4 K: -100 to 1350 °C DAQN-THERM-5 J: -100 to 760 °C	-	BW: 4 Hz	ISO: 1 kV <sub>RMS</sub>
<b>DAQN-RTD-x</b> 	Thermoresistors	Pt100 DAQN-RTD-1: -30 to 170 °C DAQN-RTD-2: -100 to 200 °C DAQN-RTD-3: -50 to 600 °C	-	BW: 10 Hz	-
<b>Frequency measurement</b>					
<b>DAQP-FREQ-A</b> 	Frequency	100 Hz to 200 kHz	-	BW: according to range Output response: 1.5 ms 30 ms 500 ms	ISO: 350 V <sub>DC</sub>
<b>Voltage output module</b>					
<b>DAQN-V-OUT</b> 	Voltage output	1:1 output module with isolation Input voltage: $\pm 10$ V Output voltage: $\pm 10$ V	-	BW: 400 Hz	ISO: 240 V <sub>DC</sub>

<sup>1)</sup> TEDS support for DAQP-BRIDGE-B revision 2 only

■ = standard

## Power supply

### 400 W AC power supply

400 W AC power supply		BEA-640	
Input:			
Rated input voltage:	100 to 240 V <sub>AC</sub> (max. 90 to 264 V <sub>AC</sub> ); active PFC		
Input frequency:	47 to 63 Hz		
Max. input current:	7 A (115 V <sub>AC</sub> ), 3.5 A (230 V <sub>AC</sub> )		
Output:			
Output power:	max. 400 W		
Output voltages:	+3.3 V (max. 28 A)		
	+5 V (max. 35 A)	-5 V (max. 0.5 A)	
	+5 Vsb (max. 2 A)		
	+12 V (max. 30 A)	-12 V (max. 0.8 A)	

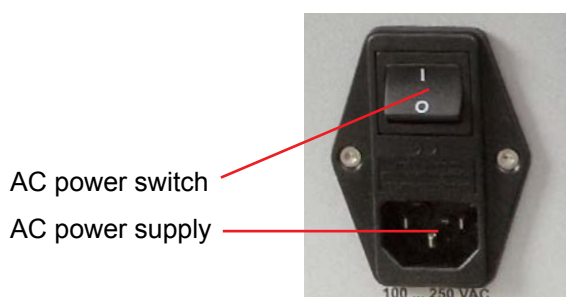

The used power supply input connectors depend on configuration and are customer-specific.

### 300 W DC power supply

300 W DC power supply		DX 300HEW	
Input:			
Input range:	9 to 18 V <sub>DC</sub> (12 V <sub>DC</sub> nom.)		
Input frequency:	DC		
Max. input current:	50 A		
Output:			
Output power:	250 W		
Output voltages:	+3.3 V (max. 20 A)		
	+5 V (max. 35 A, min. 3 A)	-5 V (max. 0.3 A)	
	+5 Vsb (max. 2 A)		
	+12 V (max. 18 A, min. 0.5 A)	-12 V (max. 2 A)	



# Main System

---

## 300 W DC power supply

300 W DC power supply		APT-DY300HEW	
Input:			
Input range:	18 to 36 V <sub>DC</sub> (24 V <sub>DC</sub> nom.)		
Input frequency:	DC		
Max. input current:	25 A		
Output:			
Output power:	300 W		
Output voltages:	+3.3 V (max. 28 A)		
	+5 V (max. 30 A, min. 3 A, peak 35 A)	-5 V (max. 1 A)	
	+5 Vsb (max. 1.5 A)		
	+12 V (max. 12 A, min. 1 A, peak 15 A)	-12 V (max. 2 A)	



# DEWESoft™

## DEWESoft™ Software Turns our Hardware into a Powerful Data Acquisition System



Our award-winning data acquisition package is second to none when it comes to both pure recording power and ease of use. Normally it is a difficult balancing act to provide lots of capability and performance, without making the user interface cumbersome and hard to learn. But with careful and innovative design, we have done exactly that!

The software can act as a simple multi-meter or recorder as well as a sophisticated combustion analyzer or power analyzer. Or anything in between these extremes, like a FFT analyzer, transient recorder, etc.

Over 10 years DEWESoft™ evolved into a great data acquisition software and is Nr.1 in synchronous acquisition of vastly different signals like analog, digital, CAN, GPS, PCM, counter, video, etc. In 2010 with the release of version 7, DEWESoft™ takes a big step toward become a very powerful data analysis tool for a wide range of test & measurement applications. Since many years you can utilize math channels in the measure mode for online calculations. Starting with version 7.0, captured data can be re-calculated in the analyze mode using the large suite of calculation (math) functions available in the measure mode. This eliminates the CPU performance limitations and thus provides unlimited offline calculation power.

Example: Performing a 10<sup>th</sup> order notch filter on 128 channels being sampled at 200 kS/s each. This is not possible online. But in analyze mode it's easy. Simply record the data and then filter it afterwards (math functions are non-destructive, i.e., they do not affect the raw channels).

Another important new feature is the sequencer which provides a way to automate test procedures.

### Key Features of DEWETRON systems running DEWESoft™

- Fast and easy setup
- Perfect sync of vastly different signals like analog, digital, counter, CAN, XCP, GPS, Video, ARINC, 1553, etc.
- Powerful online data processing, MATH functions, filters, statistics, reference curves
- Attractive online display of all kind of data, creation of displays is a matter of seconds
- Analog, digital or CAN data output; powerful function generator, alarms, CAN messages
- Build test procedures in a form of workflow diagram by means of sequencer
- Fast data analysis, reload GByte files in seconds
- Post processing, large suite of calculation (math) functions

## Hardware Support

DEWESoft™ supports DEWETRON hardware cards as well as some third-party cards, like Spectrum cards for transient recording. Multiple cards of the same family are supported for high channel counts.

There is also a huge range of DEWETRON signal conditioners which are all perfectly implemented into the software.

Besides the analog inputs DEWESoft™ supports the digital I/Os, counters and CAN interfaces of DEWETRON hardware.

To acquire video streams in sync with the analog data there is a selection of DEWE-CAM cameras.

Further bus systems like PCM telemetry, XCP, ARINC, 1553, etc. are supported, too. DEWETRON offers the appropriate hardware for all of these.

For position and speed measurements there is a choice of high performance DEWE-VGPS sensors. Or use low-cost sensor which is NMEA compatible for simple position plotting and mapping applications.



DAQx modules



DEWE-ORION A/D cards

## Sensor Database and TEDS (Technical Electronic Data Sheet)

The DEWESoft™ data acquisition software suite was developed especially for measurement technicians, thus simple sensor “connection” is a major topic. Basic settings like sensor setup are easily done. TEDS technology of newer sensors is supported on both the hardware and software side, so that all settings follow automatically, preventing user errors and saving a huge amount of time. For sensors without TEDS, there are numerous options for manual scaling as well as an integrated sensor database to make settings as efficient as possible.

#	Group	Sensor type	Serial number	Scale type	Transfer curve	Recal. date
1	Current	B0133	A_En_R01226-X	Polynom	Yes	01.04.2011
2	Current	B0133	A_En_R01226-Y	Polynom	Yes	01.04.2011
3	Current	B0133	A_En_R01226-Z	Polynom	Yes	01.04.2011
4	Beschl./Entsch.	B0132	A_En_R01229-X	Linear	No	21.05.2011
5	Wegaufl./Megaton	M101	328947	Linear	No	14.09.2010
6	Beschl./FGP	FGP	254.759	Linear	No	22.11.2010
7	Beschl./FGP	FGP	254.759	Linear	No	22.11.2010
8	Beschl./Entsch.	B0131	A_En_R01233-Y	Linear	No	01.01.2020
9	Beschl./Entsch.	B0131	A_En_R01233-Z	Linear	No	01.01.2020
10	Beschl./Entsch.	B0360	A_En_W98219-X	Linear	No	01.01.2020
11	Beschl./Entsch.	B0360	A_En_W98318-Y	Linear	No	01.01.2020

## Video Recording

A camera is a perfect sensor for many applications and a lot of people like to use it in their data acquisition. Video is a useful test documentation, providing a visual record of the test conditions and setup. It can also be used for more in-depth analysis, as you can imagine. There is nothing quite like seeing your data replayed with synchronized video – this DEWETRON innovation provides a whole new level of context and understanding of your test data than you could ever imagine.



## 3D Graph

In the properties panel there is a function that allows you to edit the properties of the selected display, and to create new displays, and rearrange them. You can rename any display, and select a different icon for it. Of course you can add sub-displays to any main display.

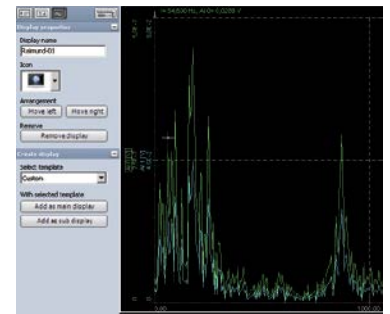

## Display Screens

One of the most powerful and yet easy to use aspect of DEWESoft™ is the creation of displays. Of course a few standard displays like Recorders, Oscilloscope, FFT, Meters, Bars, 2D and 3D graphs, etc. are built-in for you. But this is only the beginning. You simply can create custom displays according to the needs of specific test.

## Project Setup

The project files setup the measurement instruments in seconds including complete hardware setup, measurement configuration, and sensor calibration.

Since DEWESoft version 7 you can create “Projects” at the hardware setup screen level, where each project contains all of the settings for any hardware that you own. You can have an unlimited number of hardware setups, which you can freely name and edit. When you start DEWESoft 7, it will automatically load the last hardware setup that you used, of course ... but if you have changed the hardware, you can simply choose a different project from the “Settings” menu, and a completely different hardware setup will be loaded.

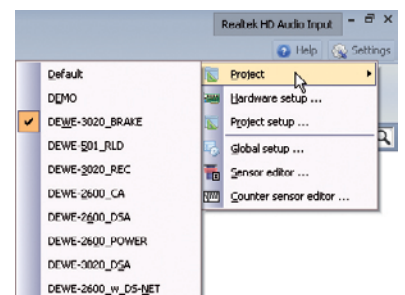

Even when using the same hardware, projects allows using different folders

for setup, data and exported files. So you can create John and George projects for different users and work without interfering or you can create e.g. Road-Load and DSA projects for different tasks.

## Recording

You can control recording as simple as pressing the START, STORE and STOP buttons. But there are also versatile trigger options to e.g. only store data if a trigger event occurs or to store at a slow rate usually but store at a fast rate at a trigger event with definable pre- and post times.

There is a large suite of calculation (math) functions which can be applied to any channels.

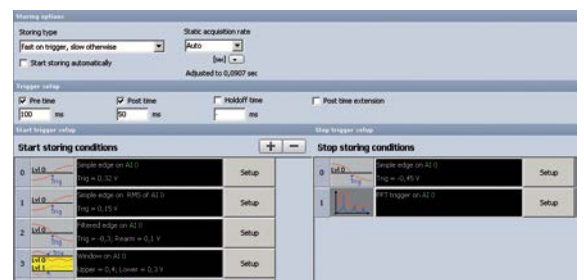

## Analyze – Replay, Re-calculate, Export

In Analyze mode you can replay any captured data file, zoom in, make cursor measurements, print reports and export the data to a wide variety of formats, like Flexpro, Excel, Matlab, Diadem and many more.

Since version 7 all the powerful math functions such as math formulas, filtering, statistics, power analysis, frequency response function, order tracking, torsional vibration, engine combustion analysis, sound analysis, human vibration analysis, and others can also be applied off-line to captured data. So you can simply store the raw data and do all the processing off-line, on any computer, anywhere. This allows you to work with the data as you were at the test bench or on the proving ground.

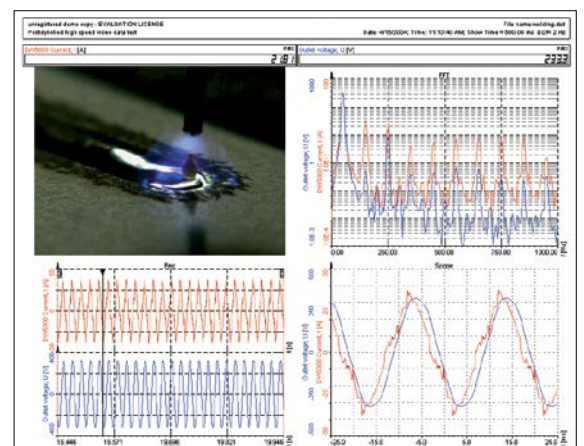

## Notes

# A/D & D/A Conversion

---

## **A/D Conversion**

Please find information about the A/D conversion in the attached DEWE-ORION series manual. The latest version of the manual can be downloaded from:

<http://download.dewetron.com/dl/components/adboards>

Informations regarding different manufacturer's see the corresponding D/A card manual.

# A/D & D/A Conversion

---

Notes

## 16 slot DEWE-MOTHERBOARD DAQ-MOTH-16-DE-x

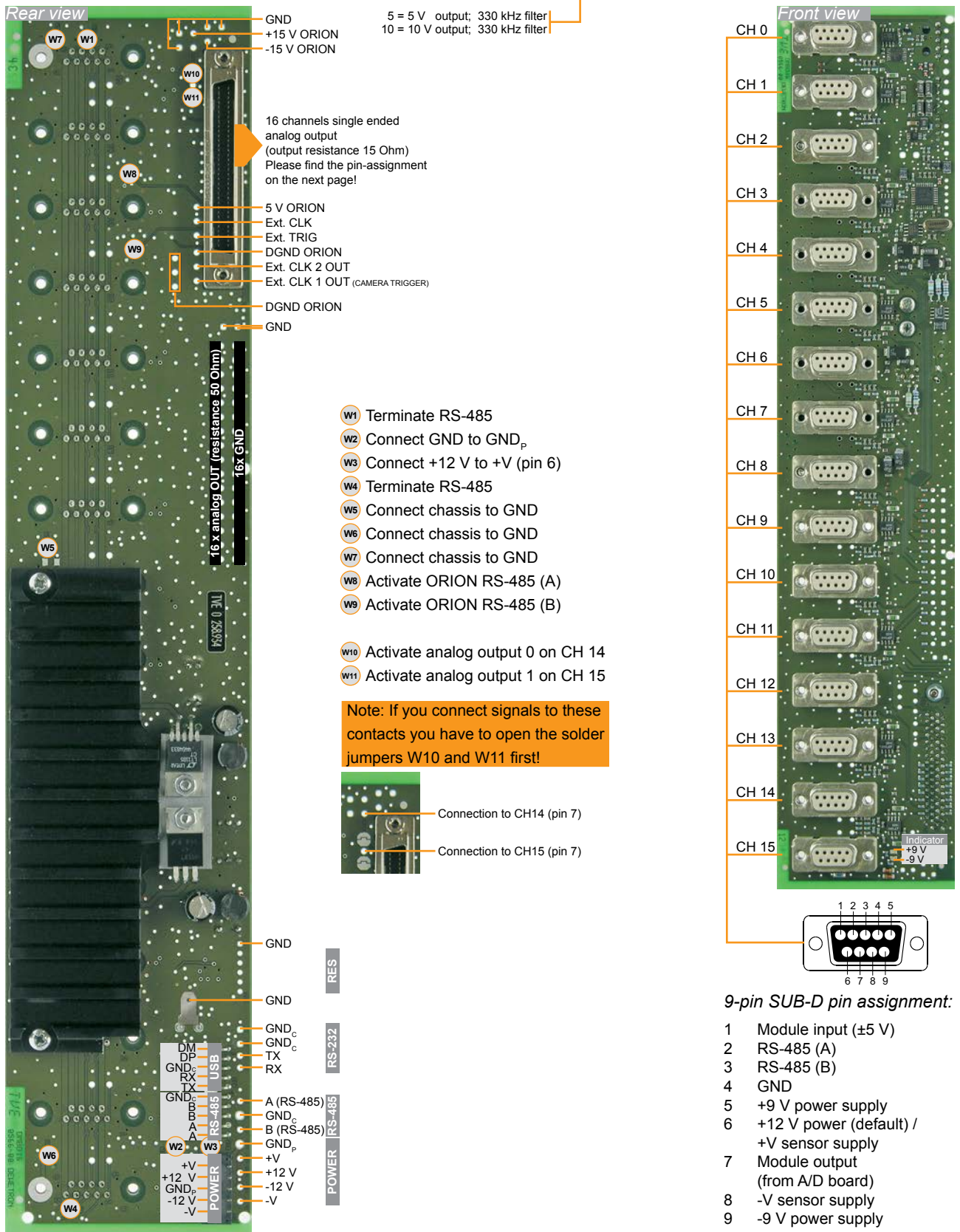

The 16 slot DEWE-MOTHERBOARD receives the  $\pm 12$  V<sub>DC</sub> power supply via a DC/DC converter from the internal power supply.

# Internal Wiring

## Analog output connector pin-assignment

Connector for DEWE-ORION-1616 cards

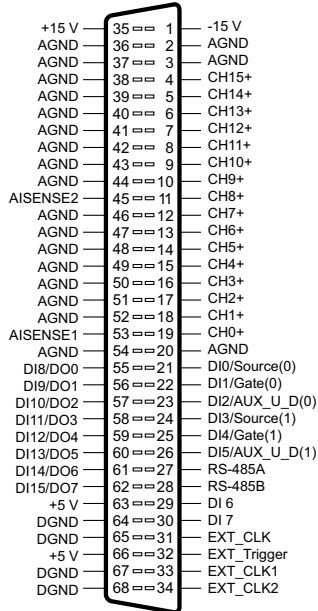

68-pin high density connector

Connector for DEWE-ORION-1624 cards

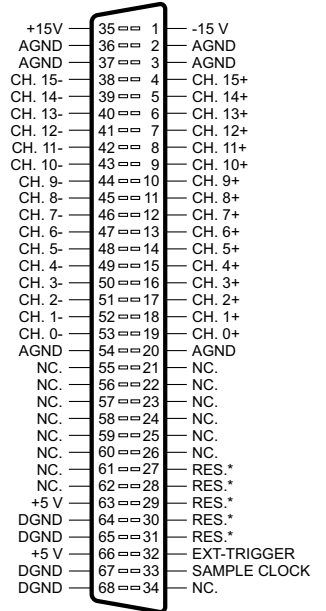

\* DONT CONNECT

68-pin high density connector

## 16 slot DEWE-MOTHERBOARD DAQ-MOTH-16-NI-x-U

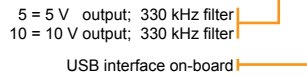

Connector for National Instruments™ A/D cards

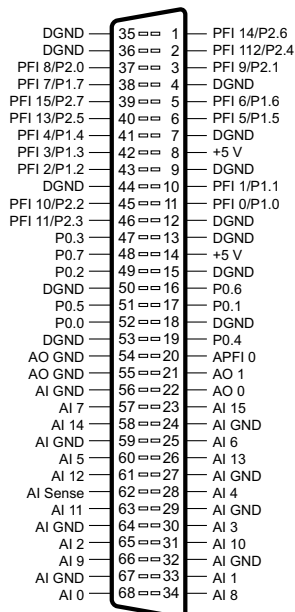

68-pin high density connector

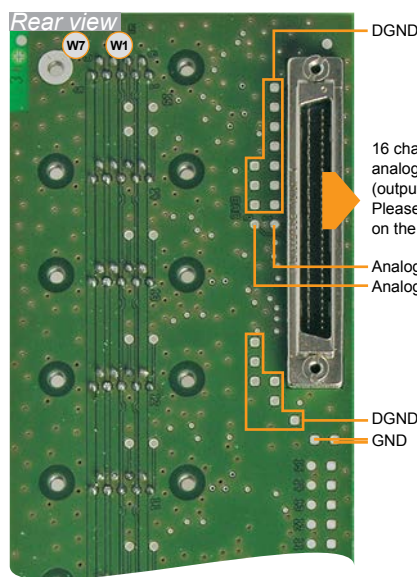

DGND

16 channels single ended analog output (output resistance 15 Ohm)  
Please find the pin-assignment on the next page!

Analog OUT Ch. 1  
Analog OUT Ch. 0

- W1 Terminate RS-485
- W2 Connect GND to GND<sub>p</sub>
- W3 Connect +12 V to +V (pin 6)
- W4 Terminate RS-485
- W5 Connect chassis to GND
- W6 Connect chassis to GND
- W7 Connect chassis to GND

# CE-Certificate of conformity



Manufacturer:

**DEWETRON Elektronische Messgeraete Ges.m.b.H.**

Address:

**Parkring 4  
A-8074 Graz-Grambach Austria**

Tel.: +43 316 3070 0

Fax: +43 316 3070 90

e-mail: sales@dewetron.com

http://www.dewetron.com

Name of product:

**DEWE-820-PFR**

Kind of product:

*Power Fault Recorder*

The product meets the regulations of the following EC-directives:

**73/23/EEC**

**"Directive on the approximation of the laws of the Member States relating to electrical equipment designed for use within certain voltage limits amended by the directive 93/68/EEC"**

**89/336/EEC**

**"Directive on the approximation of the laws of the Member States relating to electromagnetic compatibility amended by the directives 91/263/EEC, 92/31/EEC, 93/68/EEC and 93/97/EEC"**

The accordance is proved by the observance of the following standards:

<b>L V E M C</b>	<b>Safety</b>	IEC/EN 61010-1:1992/93 IEC/EN 61010-2-031	IEC 61010-1:1992/300 V CATIII PoI. D. 2 IEC 1010-2-031
	<b>Emissions</b>	EN 61000-6-4	EN 55011 Class B
	<b>Immunity</b>	EN 61000-6-2	Group standard

**Graz, April 28, 2010**

Place / Date of the CE-marking

Dipl.-Ing. Roland Jeutter / Managing director

# Notes

---