

Content

General Information, Safety Instructions	5
Warranty Information	5
Support	5
Printing History.....	5
Safety symbols in the manual	6
Safety instructions for all DEWETRON systems	7
Environmental Considerations	8
Main System	9
2 channel combustion analyzer.....	9
System specifications	9
Connectors	10
Special Combustion Analyzer I/O connectors.....	15
DAQP-CHARGE-B	17
Dynamic signal amplifier	17
Module specifications	17
LED state	17
Input range and filter selection	18
Block diagram	18
Sensor connection	19
Power consumption.....	19
Isolation.....	19
A/D & D/A Conversion	A1
Declaration of conformity	C1

Technical Reference

The information contained in this document is subject to change without notice.

DEWETRON elektronische Messgeraete Ges.m.b.H. (DEWETRON) shall not be liable for any errors contained in this document. DEWETRON MAKES NO WARRANTIES OF ANY KIND WITH REGARD TO THIS DOCUMENT, WHETHER EXPRESS OR IMPLIED. DEWETRON SPECIFICALLY DISCLAIMS THE IMPLIED WARRANTIES OF MERCHANTABILITY AND FITNESS FOR A PARTICULAR PURPOSE. DEWETRON shall not be liable for any direct, indirect, special, incidental, or consequential damages, whether based on contract, tort, or any other legal theory, in connection with the furnishing of this document or the use of the information in this document.

Warranty Information

A copy of the specific warranty terms applicable to your DEWETRON product and replacement parts can be obtained from your local sales and service office.

Support

For any support please contact your local distributor first or DEWETRON directly.

For Asia and Europe, please contact:

DEWETRON Ges.m.b.H.
Parkring 4
A-8074 Graz-Grambach
AUSTRIA
Tel.: +43 316 3070
Fax: +43 316 307090
Email: support@dewetron.com
Web: <http://www.dewetron.com>

The telephone hotline is available
Monday to Friday between
08:00 and 17:00 CET (GMT +1:00)

For the Americas, please contact:

DEWETRON, Inc.
10 High Street, Suite K
Wakefield, RI 02879
U.S.A.
Tel.: +1 401 284 3750
Toll-free: +1 877 431 5166
Fax: +1 401 284 3755
Email: support@dewamerica.com
Web: <http://www.dewamerica.com>

The telephone hotline is available
Monday to Friday between
08:00 and 17:00 GST (GMT -5:00)

Restricted Rights Legend

Use austrian law for duplication or disclosure.

DEWETRON GesmbH
Parkring 4
A-8074 Graz-Grambach / Austria

Printing History

Please refer to the page bottom for printing version.

Copyright © DEWETRON elektronische Messgeraete Ges.m.b.H.

This document contains information which is protected by copyright. All rights are reserved. Reproduction, adaptation, or translation without prior written permission is prohibited, except as allowed under the copyright laws.

All trademarks and registered trademarks are acknowledged to be the property of their owners.

Safety instructions

Safety symbols in the manual



Indicates hazardous voltages.

WARNING *Calls attention to a procedure, practice, or condition that could cause bodily injury or death.*

CAUTION *Calls attention to a procedure, practice, or condition that could possibly cause damage to equipment or permanent loss of data.*

WARNINGS

The following general safety precautions must be observed during all phases of operation, service, and repair of this product. Failure to comply with these precautions or with specific warnings elsewhere in this manual violates safety standards of design, manufacture, and intended use of the product. DEWETRON Elektronische Messgeraete Ges.m.b.H. assumes no liability for the customer's failure to comply with these requirements.

All accessories shown in this document are available as option and will not be shipped as standard parts.



*For safety reasons max. 50 V may be applied to the BNC input-connectors!
Refer to the regulation of maximum allowable touch potential.*

Safety instructions for all DEWETRON systems

- The DEWETRON data acquisition systems may only be installed by experts.
- Read your manual before operating the system.
- Observe local laws when using the instrument.
- Ground the equipment: For Safety Class 1 equipment (equipment having a protective earth terminal), a non interruptible safety earth ground must be provided from the mains power source to the product input wiring terminals or supplied power cable.
- DO NOT operate the product in an explosive atmosphere or in the presence of flammable gases or fumes and do not bring the system in contact with water.
- DO NOT operate damaged equipment: Whenever it is possible that the safety protection features built into this product have been impaired, either through physical damage, excessive moisture, or any other reason, REMOVE POWER and do not use the product until safe operation can be verified by service-trained personnel. If necessary, return the product to a DEWETRON sales and service office for service and repair to ensure that safety features are maintained.
- Keep away from live circuits: Operating personnel must not remove equipment covers or shields. Procedures involving the removal of covers or shields are for use by service-trained personnel only. Under certain conditions, dangerous voltages may exist even with the equipment switched off. To avoid dangerous electrical shock, DO NOT perform procedures involving cover or shield removal unless you are qualified to do so.
- No modifications are allowed at the instrument. The fuse in the power module has to be replaced by the same type. For continued protection against fire, replace the line fuse(s) only with fuse(s) of the same voltage and current rating and type. DO NOT use repaired fuses or short-circuited fuse holder labels and print on the power module may not be removed.
- DO NOT service or adjust alone. Do not attempt internal service or adjustment unless another person, capable of rendering first aid and resuscitation, is present.
- DO NOT substitute parts or modify equipment: Because of the danger of introducing additional hazards, do not install substitute parts or perform any unauthorized modification to the product. Return the product to a DEWETRON sales and service office for service and repair to ensure that safety features are maintained.
- Before opening the instrument (experts only) or exchanging the fuse in the power module disconnect power!
- Don't touch internal wiring!
- Don't use higher supply voltage than specified and take care of the correct polarity, otherwise the system will be damaged!
- Use only original plugs and cables for harnessing.
- Install filler-panels in unused slots.
- The power-cable and -connector serve as Power-Breaker. The cable must not exceed 10 feet, disconnect function must be possible without tools.
- Keep the ventilation slots free and check them frequently to avoid an overheating of the system. The cleaning interval of the filter pads depends on the environmental conditions.
- Safety of the operator and the unit depend on following these rules.
- DEWETRON is not responsible for any damage or injury that could result from improper connection or misuse!

General Information

CAUTION

- The system BIOS is protected by password. Any change in the BIOS may cause a system crash. When the system is booting, do not press ESC-button on keyboard. This may clear the BIOS settings and cause system faults.
- Any change in the file structure as deleting or adding files or directories might cause a system crash.
- Before installing software updates contact DEWETRON or your local distributor. Use only software packages which are released by DEWETRON. Further informations are also available in the internet (<http://www.dewetron.com>).
- After power off the system wait at least 10 seconds before switching the system on again. Otherwise the system may not boot correct. This prolongs also the life of all system components.

Environmental Considerations

Information about the environmental impact of the product.

Product End-of-Life Handling

Observe the following guidelines when recycling a DEWETRON system:

System and Components Recycling

Production of these components required the extraction and use of natural resources. The substances contained in the system could be harmful to your health and to the environment if the system is improperly handled at it's end of life! Please recycle this product in an appropriate way to avoid an unnecessary pollution of the environment and to keep natural resources.



This symbol indicates that this system complies with the European Union's requirements according to Directive 2002/96/EC on waste electrical and electronic equipment (WEEE). Please find further informations about recycling on the DEWETRON web site www.dewetron.com



Restriction of Hazardous Substances

This product has been classified as Monitoring and Control equipment, and is outside the scope of the 2002/95/EC RoHS Directive. This product is known to contain lead.

2 channel combustion analyzer

- Rugged small-size standalone instrument
- 2 DAQP-CHARGE-B inputs
- 6 direct voltage inputs
- 2 counter input (encoder), CAN-bus optional
- RS-485, prepared for EPAD expansion
- Local data storage or online data transfer via Ethernet
- A/D converter specs see appendix A



System specifications

	DEWE-201	
Power supply	8 to 24 V _{DC} (startup voltage 9 V, jumper setting 0)* 8 to 24 V _{DC} (startup voltage 12 V, jumper settings 1 - 7)*	
Operating temperature	0 °C to +50 °C	
Storage temperature	-20 °C to +70 °C	
Humidity (operating)	10 % to 80 %, non condensing 5 % to 95 %, rel. humidity	
Vibration test EN 60068-2-6	Shape	Sine
	Frequency range	10 - 150 Hz
	Acceleration	2 g
	Sweep rate	1 oct./min.
	Duration	20 Cycles
	Test in 3 directions	
Vibration test EN 60721-3-2 Class 2M2	Shape	Random
	Frequency range	10 - 200 Hz
	Power spectral density	1 m/s ² / Hz from 10 – 200 Hz
	Duration	30 Minutes per axis
Shocktests EN 60068-2-27	Shape	Half-sine
	Acceleration amplitude	15 g
	Duration	11 ms
	Test in 3 axis, 3 shocks in each axis and direction	
Dimensions (W x D x H)	285 x 230 x 88 mm (11.2 x 3.5 x 0.9 in.)	
Weight	typ. 4 kg (8.8 lbs), depending on configuration	

*) for further informations please refer to chapter: Smart power supply.

Main System

Connectors

Connector overview:

- | | |
|--|---|
| 1 Power-on button | 11 Audio inputs |
| 2 Ground connector | 12 PS/2 connector |
| 3 Direct voltage inputs | 13 Ethernet LAN connector |
| 4 DAQP-CHARGE-B inputs | 14 DVI connector |
| 5 Digital I/O connector | 15 Signal output 1 (wiring according to appendix B) |
| 6 EPAD interface | 16 Signal output 2 (wiring according to appendix B) |
| 7 USB interface connectors | 17 Crank Angle Sensor |
| 8 WLAN antenna | 18 CDM - angle position signal from high resolution encoders, TTL level input |
| 9 Power supply for accessories (12 VDC) Lemo FGG.1B.302 | 19 'Zero position' signal (upper death point signal), TTL level input |
| 10 Power supply input (EGJ.2B.303.CLA) | 20 CA Connector |

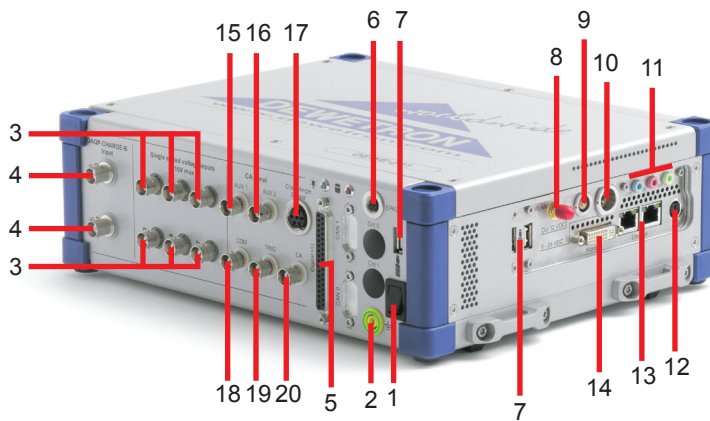

Typical DEWE-201-CA2-PROF front view

Note: The location of the connectors might vary from system to system and depends on system configuration

Dimensions*

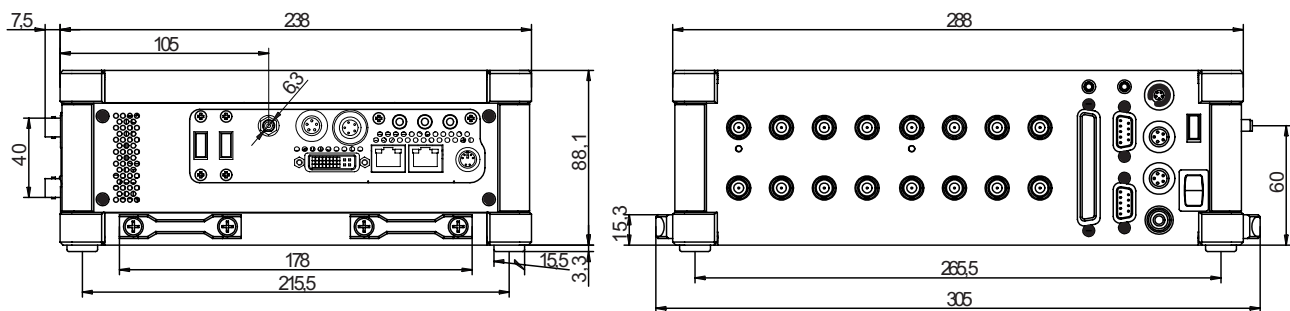

* Dimensions in mm
(1 inch = 25.4 mm)

Internal DC power supply

160 W DC power supply	
Input:	
Input range:	8 to 24 V _{DC} (startup voltage min. 9 V _{DC} , lab mode)* 8 to 24 V _{DC} (startup voltage min. 12 V _{DC} , in-vehicle mode)*
Input frequency:	DC
Max. input current:	15 A

¹⁾ For further informations please refer to chapter: Smart power supply.

Power supply pin assignment:

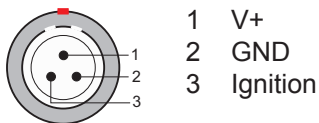

Lemo EGJ.2B.303.CLA

SMART Power supply

This device is equipped with a smart power supply. It can be configured for two different modes

1.) Lab mode

The device is powered through AC mains via an external AC/DC converter. Please set the jumpers as follows:



In this mode the DEWE-201 acts like a standard ATX compatible computer.

Note: like all such ATX compatible PC systems, the DEWE-201 will draw a little current also in power-off mode

Note: In the lab mode the system won't boot up below 8V supply voltage.

2.) In-vehicle mode

The device is powered out of the vehicle. Please set the jumpers as follows:



In this mode, the DEWE-201 senses the IGN pin for automatic power on / shut down. It is recommended to connect the IGN of the vehicle to the IGN pin. Without high level on this Pin, the system won't start.

- Connect to the vehicles power supply
- Switch on the ignition. After about 5 seconds the system will start to boot up. (I it supposed that in these 5 seconds the engine has been started)
- The device now can be shut down using the front button, as usual
- The device now can be shut down using the windows function, as usual
- If you switch off the ignition, after about 5 seconds the system will shut down automatically. After about 45 seconds, the device will shut off hard, even if Windows hangs.

Main System

Note: In the in-vehicle mode, the DEWE-201 will shut off completely after 45 seconds. So it can remain on the power supply also for long term without discharging the battery.

Attention: In the in-vehicle mode the system won't boot up below 11,5V supply voltage.

PS/2 mouse / keyboard connector

The mouse / keyboard connector could be used to connect a keyboard or an external PS/2 mouse. The connector meets standard PS/2 pin assignment.

USB interface connectors (Universal Serial Bus)

The USB interface connectors meets standard USB pin assignment.

VGA connector

The VGA connector offers the possibility to connect a CRT or other standard VGA displays to the system.

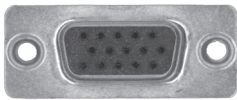

15-pin mini-SUB-D connector (male)

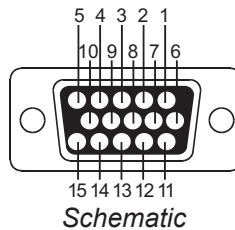

Pin assignment

- 1: Red video
- 2: Green video / Sync on green
- 3: Blue video
- 4: -
- 5: -
- 6: Red video ground
- 7: Green video ground
- 8: Blue video ground
- 9: -
- 10: Ground
- 11: Ground
- 12: Data line
- 13: H-Sync / HV-Sync
- 14: V-Sync
- 15: Clock line

Some systems have a DVI connector instead or additionally to the VGA.

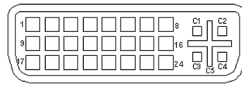

15-pin mini-SUB-D connector (male)

Schematic

Pin assignment

1: TDMS-data 2-	9: TDMS-data 1-	17: TDMS-data 0-	C1: Analog: red
2: TDMS-data 2+	10: TDMS-data 1+	18: TDMS-data 0+	C2: Analog: green
3: Shield TDMS-data 2,4	11: Shield TDMS-Daten 1,3	19: Shield TDMS-data 0,5	C3: Analog: blue
4: TDMS-data 4-	12: TDMS-data 3-	20: TDMS-data 5-	C4: Analog: H-Sync
5: TDMS-data 4+	13: TDMS-data 3+	21: TDMS-data 5+	C5: Analog: ground
6: DDC clock	14: +5 volt	22: Shield TDMS-Takt	
7: DDC data	15: Ground for +5 volt	23: TDMS-clock+	
8: Analog: V-Sync	16: Hotplug-Detect	24: TDMS-clock -	

Ethernet connector

The DEWE-201 system supports 10/100/1000 BaseT Ethernet with standard RJ45 connector.

Power-on button

When the power-on button is pressed while the DEWE-201 is already at Windows, the DEWE-201 will shut down. Press the power-on button for more than 3 seconds while the DEWE-201 is starting into Windows or when the DEWE-201 doesn't shut down at the normal way.

Digital I/O connector

This connector supports digital input and output lines of the built-in A/D board. If this board does not support digital I/O's, the connector is not available.

The pin assignment is depending on the used A/D board - details are available in appendix B.

Ground connector

For some kind of measurements, it's necessary to give the system an additional ground connection.

Power supply for accessories

To supply your accessories with 12 VDC. Plug in your accessories before starting the DEWE-201, otherwise it could happen that the DEWE-201 will reboot.



Lemo FGG.1B.302

EPAD connector

To connect DEWETRON EPAD modules to the system.

Main System

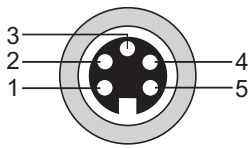

5-pin. Binder connector (female)

Pin assignment

- 1: RS-485 A
- 2: RS-485 B
- 3: +12 V
- 4: GND
- 5: Shield

Digital I/O connector

All the signals of the DEWE-ORION-0816-xx series A/D card are available on this 37-pin female SUB-D connector.

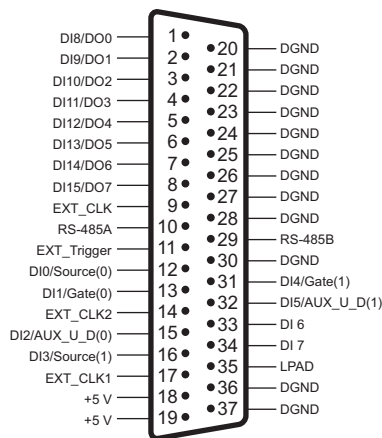

37-pin SUB-D connector

CAN interface connector (optional)

The CAN signals of the DEWE-20-CA2-PROF system are available on two 9-pin female D-SUB connectors.

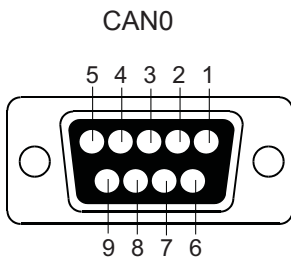

- CAN0
- 1.) +5 V
 - 2.) CAN0_L
 - 3.) GND
 - 4.) n.c.
 - 5.) n.c.
 - 6.) GND
 - 7.) CAN0_H
 - 8.) n.c.
 - 9.) +12 V

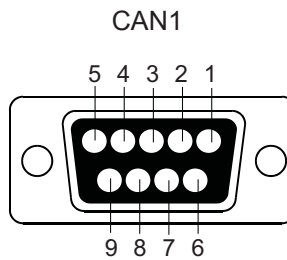

- CAN1
- 1.) +5 V
 - 2.) CAN1_L
 - 3.) GND
 - 4.) n.c.
 - 5.) n.c.
 - 6.) GND
 - 7.) CAN1_H
 - 8.) n.c.
 - 9.) +12 V

Special Combustion Analyzer I/O connectors

The Combustion Analyzer requires several special input signals to work.

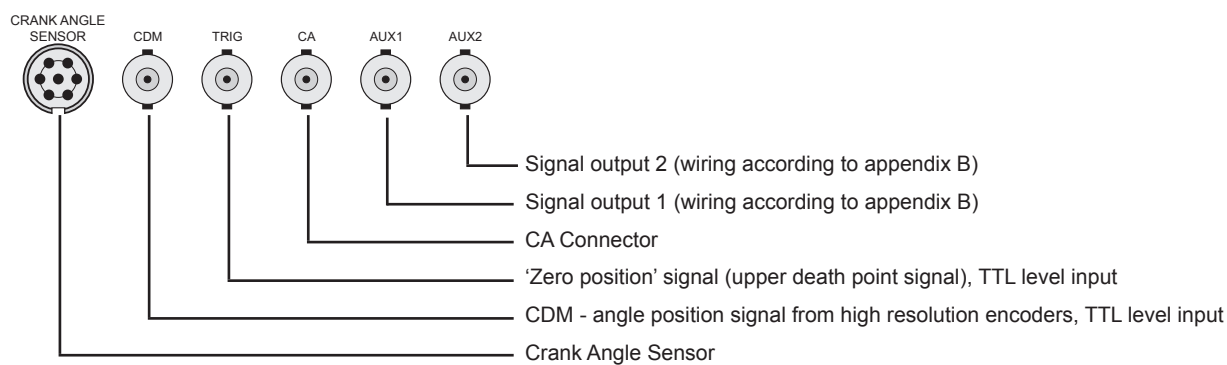

Crank angle encoder

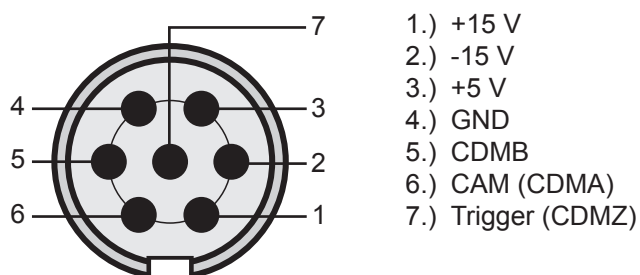

*For safety reasons max. 50 V may be applied to the BNC input-connectors!
Refer to the regulation of maximum allowable touch potential.*

Main System

Notes

Dynamic signal amplifier (internally installed)

- Input protection: Isolated input (1 kV ESD)
- Input sensitivity: 8 ranges from 100 pC to 1 000 000 pC
- Dynamic: Up to 93 dB
- Charge drift: < 0.03 pC/sec
- Bandwidth, filter: 100 kHz, 9 selectable low pass filters (10 Hz to 100 kHz)
- Custom range: Completely free programmable sensitivity and offset



Module specifications

	DAQP-CHARGE-B
Input ranges:	$\pm 100, \pm 500, \pm 2\,000, \pm 10\,000, \pm 40\,000, \pm 200\,000, \pm 1\,000\,000$ pC
Range selection:	Push button or software
Gain accuracy:	0.5 % of range (1 % of range for 100 and 500 pC)
Gain linearity:	± 0.05 %
Bandwidth, -3dB	100 kHz (± 1.5 dB @ f_0)
Filters (lowpass):	10 Hz, 30 Hz, 100 Hz, 300 Hz, 1 kHz, 3 kHz, 10 kHz, 30 kHz, 100 kHz (± 2 dB @ f_0)
Filter selection:	Push button or software
Filter characteristics:	Bessel or Butterworth (software programmable) 40 dB / decade (12 dB / octave)
Time constant:	
Long:	DC mode
Highpass filter on:	2 to 1000 sec.
Drift input current @ 25 °C:	< ± 0.03 pC/s
Amplifier reset:	Push button or software
Offset after reset:	± 2 mV or ± 1 pC (greater value is valid)
Typ. SNR @ max. bandwidth:	
Range 100 pC:	76 dB (82 dB @ 30 kHz / 85 dB @ 10 kHz)
Range > 2000 pC:	81 dB (89 dB @ 30 kHz / 93 dB @ 10 kHz)
Output noise:	
@ 100 kHz:	$0.3 \text{ mV}_{\text{RMS}} + 0.01 \text{ pC}_{\text{RMS}}$
@ 30 kHz:	$0.12 \text{ mV}_{\text{RMS}} + 0.008 \text{ pC}_{\text{RMS}}$
Cable noise:	< $10^{-5} \text{ pC}_{\text{RMS}}/\text{pF}$
CMR:	< 0.02 pC/V (difference between input and output ground)
Isolation:	350 V _{DC}
Input overvoltage protection:	1 kV ESD
Output voltage:	± 5 V
RS-485 interface:	Yes
Power supply voltage:	$\pm 9 \text{ V}_{\text{DC}} (\pm 1 \%)$
Power consumption:	1.5 W to 3.5 W (depending on signal range and frequency)

LED state

The DAQP-CHARGE-B series module has a set of 7 LEDs showing the current input range (constant active), the filter range (flashing). A selected custom range is displayed with constant lightening of the highest both range LEDs. The LED labeled with HP displays the state of the high pass filter: if the LED is active, the high pass filter is used, if the LED is flashing, the module is in reset mode.

Due to the large number of low pass filters, two LEDs are used to display the current frequency. The left LED indicates the multiplier, the right one shows the exponent with the base of 10. Example: for the 10 kHz frequency, the LED 1 and 4 are flashing (1×10^4 Hz = 10 000 Hz).

Main System

Input range and filter selection

The DAQP-CHARGE-B series module has two push buttons with multiple functions.

- Range button: Push the **RANGE** button several times shortly until the LED displays the desired input range. If a special custom range is defined in the module, it can be selected before the highest range ($1 \times 10^6 \text{ pC} = 1\,000\,000 \text{ pC}$) is activated.

Pressing the **RANGE** button for more than one second will activate the reset function.
- Filter button: Push the **FILTER** button once - the LEDs will flash for approx. 3 seconds and display the current lowpass filter setting.

Push the **FILTER** button within the three seconds several times until the flashing LED displays the desired filter range.

Pressing the **FILTER** button for more than one second will activate the highpass filter.

Block diagram

Base block diagram of the DAQP-CHARGE-B module:

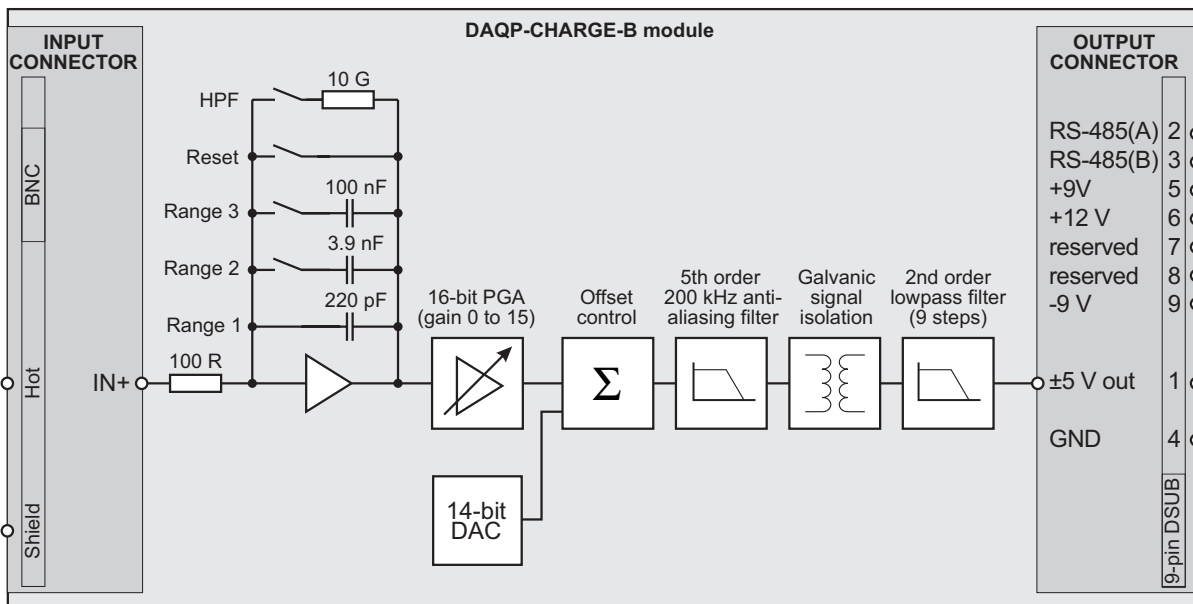

High pass filter

As shown in the schematic of the DAQP-CHARGE-B the time constant of the internal highpass filter depends on the used input range. For Range 1 (100 pC, 500 pC and 2 000 pC) the time constant is 2 seconds (or 0.07 Hz), for Range 2 (10 000 pC and 40 000 pC) the time constant is 40 seconds (or 3.9 mHz). For the highest both ranges (200 000 pC and 1 000 000 pC) the time constant is 1000 seconds or 0.16 mHz.

Sensor connection



A BNC to Microdot adapter is available as an option.

Power consumption

Charge is defined by current multiplied with time ($Q = I \times t$). That means that every charge amplifier (or better: charge to voltage converter) requires more power if the charge amplitude or the frequency increases. The relation between power, charge and frequency is defined by:

$$P [W] = Q [pC] \times f [Hz] \times 6.28 \times 10^{-11}$$

That means that the DAQP-CHARGE-B requires 6.28 W at 100 kHz and 1 000 000 pC of additional power (or 0.628 W @ 10 kHz and 1 000 000 pC). But the internal amplifier (and also the DEWE-RACK) is limited to 2 W for additional power.

Although this limitation the DAQP-CHARGE-B can also used with a 100 kHz and 1 000 000 pC signal for a short time. Up to 50 cycles with that high frequency can be handled without any limitation. After this 50 cycles it is necessary to have a break of at least 100 cycles to be within the maximum average power consumption.

Isolation

The DAQP-CHARGE-B series module offers an isolation between input and output (= factory default). This will eliminate nearly all errors which occur if the input GND (= sensor GND) has not exactly the same potential than the GND of the data acquisition system.

Different locations have different potential. Therefore errors may occur if many sensors are mounted on different locations.

But if the ground of the charge sensor is isolated or the potential where the sensor is mounted is floating better results can be achieved if the module input GND is connected to the module output GND. These can be done externally, but also with two internal jumpers. Set both jumpers to the lower position to connect the input and output GND and disable the isolation.

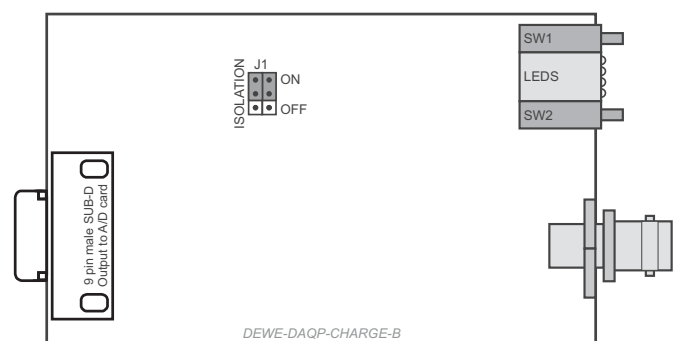

Main System

Notes

A/D & D/A Conversion

A/D Conversion

Detailed information about the A/D card are not included in this manual.

For detailed information see the manufacturer's A/D card manual.

D/A Conversion

Detailed information about the D/A card are not included in this manual.

For detailed information see the manufacturer's D/A card manual.

A/D & D/A Conversion

Notes

Declaration of conformity

Following products are in conformity with EN50081 (Electromagnetic compatibility, generic emission standard for light and heavy industry) and EN50082 (Electromagnetic compatibility, generic immunity standard for light and heavy industry):

DEWE-2000 / DEWE-2010 / DEWE-2500 series

DEWE-3000 / DEWE-3010 / DEWE-3020 series

DEWE-4000 / DEWE-4010 series

DEWE-200 series

DEWE-500 series

DEWE-5000 series

DEWE-600 series

DEWE-800 series

DEWE-900 series

DEWE-BOOK series

DEWE-RACK series

DAQ / MDAQ modules series

PAD / EPAD modules series

Note: Enhanced EMC specifications are achieved when using DC power supply input.

Manufacturer: DEWETRON Elektronische Messgeraete Ges.m.b.H.
Parkring 4
A-8074 Graz-Grambach
Austria
Tel.: +43 316 3070 0
Fax: +43 316 3070 90
e-mail: sales@dewetron.com
<http://www.dewetron.com>

Graz, Nov. 15th, 2004

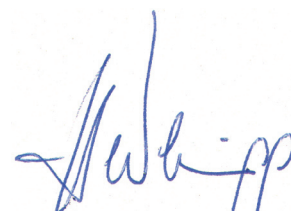

Ing. Herbert Wernigg
Managing director

Notes
