



Automotive
Energy & Power Analysis
Field Service
Environmental
Research & Development

DEWE-Modules

Technical Reference Manual



... the precision signal conditioning company



Copyright © DEWETRON elektronische Messgeraete Ges.m.b.H.

This document contains information which is protected by copyright. All rights are reserved. Reproduction, adaptation, or translation without prior written permission is prohibited, except as allowed under the copyright laws.

All trademarks and registered trademarks are acknowledged to be the property of their owners.

The information contained in this document is subject to change without notice.

DEWETRON elektronische Messgeraete Ges.m.b.H. (DEWETRON) shall not be liable for any errors contained in this document. DEWETRON MAKES NO WARRANTIES OF ANY KIND WITH REGARD TO THIS DOCUMENT, WHETHER EXPRESS OR IMPLIED. DEWETRON SPECIFICALLY DISCLAIMS THE IMPLIED WARRANTIES OF MERCHANTABILITY AND FITNESS FOR A PARTICULAR PURPOSE. DEWETRON shall not be liable for any direct, indirect, special, incidental, or consequential damages, whether based on contract, tort, or any other legal theory, in connection with the furnishing of this document or the use of the information in this document.

Warranty Information:

A copy of the specific warranty terms applicable to your DEWETRON product and replacement parts can be obtained from your local sales and service office.

Restricted Rights Legend:

Use austrian law for duplication or disclosure.

DEWETRON GesmbH

Parkring 4

A-8074 Graz-Grambach / Austria

Printing History:

Version 2.1.0

Released December 2, 2004

Copyright © 1998 - 2004 DEWETRON GesmbH

This document contains information which is protected by copyright. All rights are reserved. Reproduction, adaptation, or translation without prior written permission is prohibited, except as allowed under the copyright laws.

All trademarks and registered trademarks are acknowledged to be the property of their owners.

Notice

Safety symbols in the manual



Indicates hazardous voltages.

WARNING *Calls attention to a procedure, practice, or condition that could cause bodily injury or death.*

CAUTION *Calls attention to a procedure, practice, or condition that could possibly cause damage to equipment or permanent loss of data.*

WARNINGS

The following general safety precautions must be observed during all phases of operation, service, and repair of this product. Failure to comply with these precautions or with specific warnings elsewhere in this manual violates safety standards of design, manufacture, and intended use of the product. DEWETRON Elektronische Messgeraete Ges.m.b.H. assumes no liability for the customer's failure to comply with these requirements.

All accessories shown in this document are available as option and will not be shipped as standard parts.

Safety instructions for DEWETRON amplifiers

- The DEWETRON data acquisition systems and amplifiers may only be installed by experts.
- Read your manual carefully before operating.
- Observe local laws when using the amplifiers.
- Ground the equipment: For Safety Class 1 equipment (equipment having a protective earth terminal), a non interruptible safety earth ground must be provided from the mains power source to the product input wiring terminals or supplied power cable.
- DO NOT operate the product in an explosive atmosphere or in the presence of flammable gases or fumes.
- DO NOT operate damaged equipment: Whenever it is possible that the safety protection features built into this product have been impaired, either through physical damage, excessive moisture, or any other reason, REMOVE POWER and do not use the product until safe operation can be verified by service-trained personnel. If necessary, return the product to a DEWETRON sales and service office for service and repair to ensure that safety features are maintained.
- Keep away from live circuits: Operating personnel must not remove equipment covers or shields. Procedures involving the removal of covers or shields are for use by service-trained personnel only. Under certain conditions, dangerous voltages may exist even with the equipment switched off. To avoid dangerous electrical shock, DO NOT perform procedures involving cover or shield removal unless you are qualified to do so.
- No modifications are allowed at the amplifiers.
- DO NOT service or adjust alone. Do not attempt internal service or adjustment unless another person, capable of rendering first aid and resuscitation, is present.
- DO NOT substitute parts or modify equipment: Because of the danger of introducing additional hazards, do not install substitute parts or perform any unauthorized modification to the product. Return the product to a DEWETRON sales and service office for service and repair to ensure that safety features are maintained.
- DO NOT touch internal wiring!
- DO NOT use higher supply voltage than specified!
- Use only original plugs and cables for harnessing.
- Safety of the operator and the unit depend on following these rules.

Support

For any support please contact your local distributor first or DEWETRON directly.

For Asia and Europe, please contact:

DEWETRON Ges.m.b.H.
Parkring 4
A-8074 Graz-Grambach
AUSTRIA
Tel.: +43 316 3070
Fax: +43 316 307090
Email: support@dewetron.com
Web: <http://www.dewetron.com>

The telephone hotline is available Monday to Friday between 08:00 and 17:00 CET (GMT -1:00)

For the Americas, please contact:

DEWETRON, Inc.
PO Box 1460
Charlestown, RI 02813
U.S.A.
Tel.: +1 401 364 9464
Toll-free: +1 877 431 5166
Fax: +1 401 364 8565
Email: support@dewamerica.com
Web: <http://www.dewamerica.com>

The telephone hotline is available Monday to Friday between 08:00 and 17:00 GST (GMT +5:00)

General Module Information

Calibration information

All DEWETRON modules are calibrated at 25 °C and meet their specifications when leaving the factory. The time interval for recalibration depends on environmental conditions. Typically, the calibration should be checked once a year.

Calibration certificates are available from DEWETRON as an option. DEWETRON offers two types:

- ISO traceable DEWETRON certificate
- Calibration certificate according to ÖKD (equivalent to DKD)

This manual contains no calibration information. For self calibration, there is a separate calibration kit for the DAQ series modules available. The CAL-KIT contains the required cables, software and instructions.

Adjustment information are only mentioned if they are required for operation (e.g. DAQP-TRQ).

General module specifications

Module dimensions: 20 x 65 x 105 mm (0.79 x 2.56 x 4.13 in.)
(W x H x D without front cover and connectors)

Frontcover: 20 x 87 x 2 mm (0.79 x 3.43 x 0.08 in.)
(W x H x D without connector)

Environmental:

Temp. range storage: -30 °C to +85 °C (-30 °F to 185 °F)
Temp. range operating: -5 °C to +60 °C (-4 °F to 140 °F)

Relative humidity
(MIL202): 0 to 95 % at 60 °C, non-condensing

RFI susceptibility: ±0.5 % span error at 400 MHz, 5 W, 3 m

All modules are produced according ISO9001 and ISO14001.

Module connectors

Frontpanel connector: Accessable to the user. The connector type and pin assignment varies from module to module. Detailed pin assignment of each module is shown in the appropriate module description.

Rear connector: 9-pin male SUB-D, interface to the DEWE-System, not accessible to the user.



DAQx and PAD module
rear view

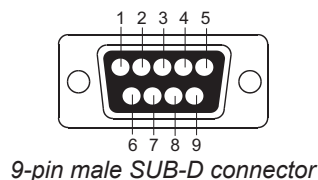

Interface pin assignment:

- 1 Module output (± 5 V)
- 2 RS-485 (A)
- 3 RS-485 (B)
- 4 GND
- 5 +9 V power supply
- 6 +12 V power / sensor supply
- 7 Module input (from D/A converter of the A/D board)
- 8 reserved
- 9 -9 V power supply

General Module Information

RS-232/485 interface

DAQP modules can be configured via RS-485 interface, PAD modules require this interface for all data transfers.

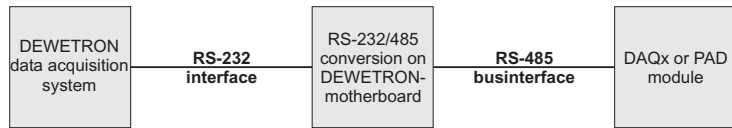

For all DEWETRON systems, an internal RS-232/485 converter is available

(standard with DEWE-2010, DEWE-3020, DEWE-4010 and DEWE-5000 systems). This converter allows communication with DAQP and PAD modules.

To communicate with the modules, the RS-232 interface has to be set to the following parameters:

baud rate:	9600 bps
data bits:	8
parity:	no parity
stop bits:	1
handshake:	not required

DAQP module configuration

1. Push button selection

All ranges and filters can be selected directly by pressing the push buttons on the module. Approx. 15 sec. after changing range and / or filter, the range and filter information is stored in an EEPROM. This procedure increases the lifetime of the EEPROM.

The current input range setting is shown all the time by LED. To change the range just press **RANGE** button a few times until the required range is displayed.

To see the current filter setting just press the **FILTER** button once. The corresponding LED is flashing for approx. 3 seconds. Within this time, the filter can be selected by pressing the **FILTER** button again. Approx. 3 seconds after the last key activity, the information will be stored, the LED stops flashing and shows the input range again.

CAUTION: Power loss during this time leaves the module in the former settings.

2. RS-232/485 programming

All ranges and filters can also be selected via RS-232/485 interface. All new DEWE-2010, DEWE-3020, DEWE-4010 and DEWE-5000 systems are prepared as a standard to work with DAQP modules.

The easiest way to change the configuration is to use the DEWEConfig software, which comes as a standard with the DEWETRON data acquisition system.

Detailed information about DAQP modules programming for customer applications is available in the *DEWE-Modules Programmers Reference Manual*.

CAUTION: All range and filter changes which are done via RS-232/485 interface are not stored in the EEPROM of the DAQP modules! You have to store this information in a separat initialisation file to keep settings information for next system start!

PAD module communication

All PAD modules are only working through the RS-232/485 interface. All new DEWE-2010, DEWE-3020 and DEWE-4010 systems are prepared as a standard to work with PAD modules. The easiest way to change the configuration is to use the DEWEConfig software, which comes as a standard with the DEWETRON data acquisition system.

Detailed information about PAD modules programming for customer applications is available in the *DEWE-Modules Programmers Reference Manual*.

Differential voltage amplifier

- Filter bandwidth: 300 kHz, 10 selectable lowpass filters (10 Hz to 300 kHz)
- Input ranges: 11 different ranges (20 mV to 50 V) unipolar and bipolar
- Input type: AC and DC coupling software selectable
- Amplifier: High signal to noise and common mode ratio
- Linearity: Very high amplifier linearity
- TEDS: Supports digital electronic data sheet sensors



Module specifications

DAQP-V-A		
Input ranges unipolar and bipolar	20 mV, 40 mV, 100 mV, 200 mV, 500 mV, 1 V, 2 V, 5 V, 10 V, 25 V, 50 V	
Push button selectable ranges	20 mV, 100 mV, 500 mV, 1 V, 5 V, 10 V, 50 V	
DC accuracy	Range	Accuracy
Bipolar	20 mV and 40 mV	±0.01 % of reading ±40 µV
	100 mV to 1V	±0.01 % of reading ±0.04 % of range
	2 V to 50 V	±0.01 % of reading ±0.04 % of range
Unipolar	20 mV and 40 mV	±0.02 % of reading ±40 µV
	100 mV to 1 V	±0.02 % of reading ±0.06 % of range
	2 V to 50 V	±0.02 % of reading ±0.06 % of range
Input coupling	DC or AC software selectable (1.5 Hz standard, cust.on request down to 0,01 Hz)	
Gain linearity	0.01 %	
Gain drift bipolar range	Typically 20 ppm/°K	
Offset drift	Bipolar	Unipolar
20 mV to 1 V	1 µV/°K	1 µV/°K
1 V ⁽¹⁾ to 50 V	50 µV/°K	10 µV/°K + 10 ppm of range/°K
Input resistance	1 MOhm	
Bandwidth	300 kHz	
Filter selection	Push button or software	
Filter	10, 30, 100, 300, 1k, 3k, 10k, 30k, 100k, 300 kHz ⁽²⁾	
Filter type	Bessel or Butterworth 40 dB/decade	
Typical SNR	300 kHz	10 kHz
20 mV	71 dB	74 dB
1 V	90 dB	93 dB
50 V	89 dB	99 dB
Typical CMR	500 mV range:	50 V range:
	100 dB @ 0Hz	80 dB @ 0 Hz
	100 dB @ 50 Hz	80 dB @ 50 Hz
	100 dB @ 10 kHz	80 dB @ 10 kHz
Input overvoltage protection	350 V _{DC}	
Maximum common mode voltage	0.2 V to 1 V range	5 V _{DC}
	1V ⁽¹⁾ to 50 V range	200 V _{DC}
Sensor supply	±9 V max 50 mA , 12 V max 50 mA, others on request	
Supply voltage accuracy	±5 %	
Output voltage	±5 V	
Output resistance	<10 Ohm	
Output current	5 mA	
Output protection	Short to ground for 10 sec.	
Power supply	±9 V _{DC} ± 1%	
Power consumption	0.6 W without sensor supply	
Operating temperature	0 to 60 °C	
Interface	RS-485	
TEDS	Hardware support for TEDS (Transducer Electronic Data Sheet)	
Supported TEDS chips	DS2406, DS2430A, DS2432, DS2433	
⁽¹⁾ 1 V high common mode range		
⁽²⁾ 300 kHz exclusively for Bessel filter characteristic		

DAQP-V-A

LED state

The DAQP-V-A module has a set of 8 LEDs showing the current input range (constant active), the filter range (flashing) and the input mode setting. Seven of the different input ranges are indicated directly by the LEDs. The additional four input ranges (only software selectable) are indicated by lightening the two “neighbour” ranges. For example the 25 V input range is shown by the LEDs 50 V and 10 V.

Due to the large number of low pass filters, two LEDs are used to display the current frequency. The left LED indicates the multiplier, the right one shows the exponent with the base of 10. Example: for the 10 kHz frequency range, the lower left and the upper right LED are flashing ($1 \times 10^4 \text{ Hz} = 10\,000 \text{ Hz}$).

The U/B LED shows the input mode: If this LED is off, the bipolar input range is selected, otherwise the unipolar mode is selected. Flashing of the LED indicates an input common mode voltage overload during the measurement cycle.

Input range and filter selection

The DAQP-V-A module has two push buttons with multiple functions.

- Range button: Push the **RANGE** button several times until the LED displays the desired input range.
Pressing the **RANGE** button for more than one second will activate the reset function.
- Filter button: Push the **FILTER** button once - the LEDs will flash for approx. 3 seconds and display the current filter setting. Push the **FILTER** button within the three seconds several times until the flashing LED displays the desired filter range.
Press the **FILTER** button for more than 3 sec. resets the common mode voltage overflow flag.

Block diagram

The base block diagram of the DAQP-V-A gives an idea of the internal structure. For ranges above 1 V the input voltage is used to get the high voltage input and common mode range. The following programmable differential amplifier combined with the calibration amplifier serves you 11 different input ranges.

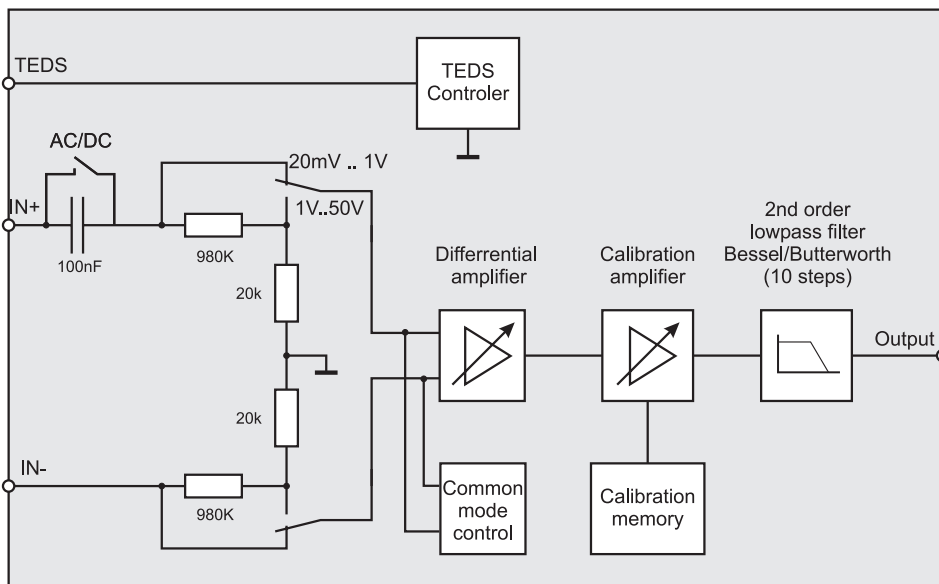

Internal solder bridges

The solder bridges can be used for special levels of sensor supply voltage. Also an area for adding an 1 Watt DC/DC converter is reserved for this kind of application. Please contact your local engineer for detailed information.

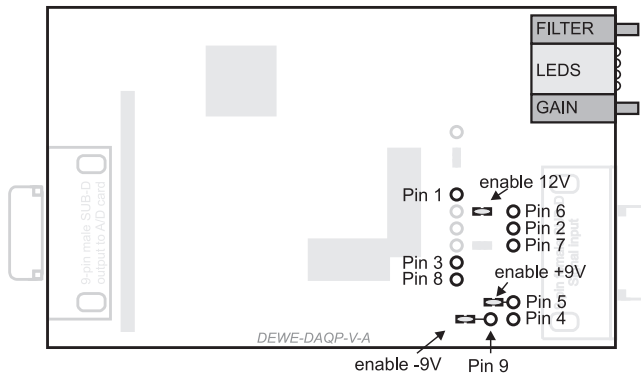

Signal connection

DAQP-V-A module



Voltage measurement
Current measurement (with shunt resistor)

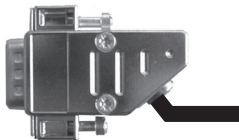

- 1 TEDS Input
- 2 Input (+)
- 3 Reserved for custom sensor supplies
- 4 GND
- 5 +9 V
- 6 +12 V
- 7 Input (-)
- 8 Reserved for custom sensor supplies
- 9 -9 V

DAQP-V-A-LEMO module



Voltage measurement via LEMO cord



- 1 Input (+)
- 2 Input (-)
- 3 +9 V
- 4 -9 V
- 5 GND
- 6 +12 V

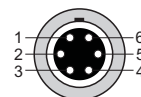

6-pin LEMO connector female
EGG.1B.306.CLA

DAQP-V-A

Typical sensor connection

Sensor with differential output powered by the module

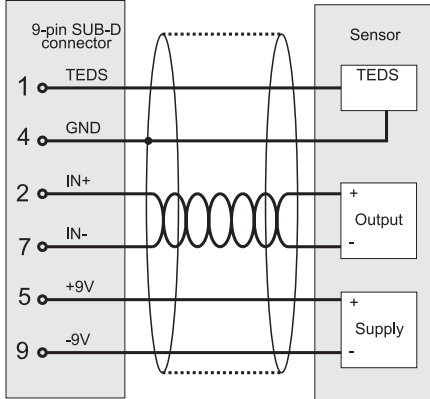

Current measurement

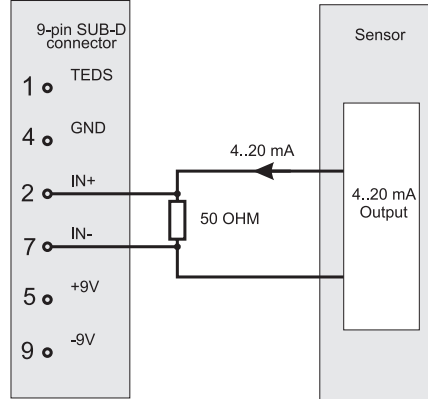

Loop powered sensor

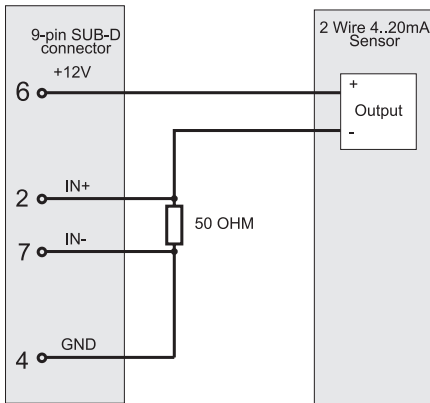

Sensor with common ground

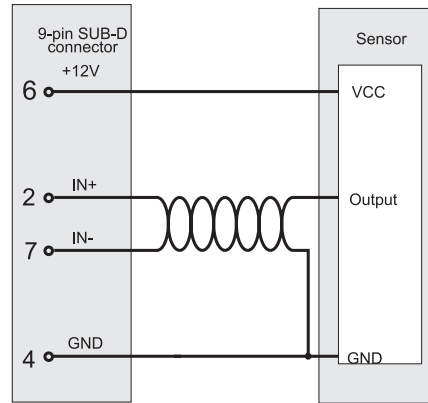

Common mode voltage range

In contrast to isolated amplifiers the input common voltage range is limited at differential amplifiers. The measurement configuration below shows to possibilities to measure the current of a 12 V supplied system.

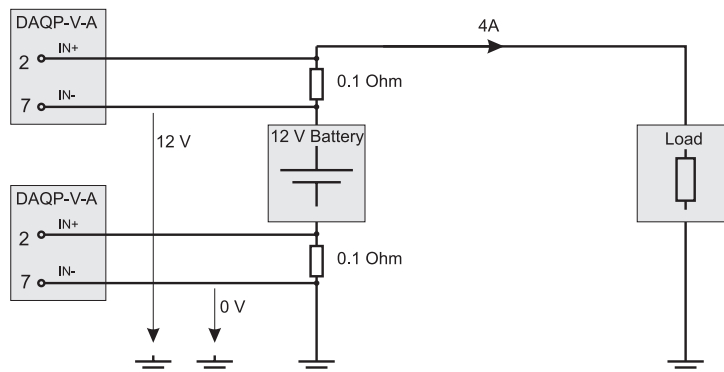

The optimum input range in that case is 500 mV. That will work fine for the lower DAQP-V-A module shown in the picture, but not for the upper one. This module will detect an overflow (U/B LED flashes) because the common mode voltage applied to this module is higher than 5 V. In that case it is necessary to select at least the '1 V high common mode' range.