



Automotive  
Energy & Power Analysis  
Aerospace & Defense  
Transportation  
General Test & Measurement

# DEWE-ORION-1622-10x

*Technical reference manual*



Test & Measurement Solutions



Copyright © DEWETRON elektronische Messgeraete Ges.m.b.H.

This document contains information which is protected by copyright. All rights are reserved. Reproduction, adaptation, or translation without prior written permission is prohibited, except as allowed under the copyright laws.

All trademarks and registered trademarks are acknowledged to be the property of their owners.  
DEWESoft™ is a trademark of Dewesoft d.o.o

## Content

<b>General Information, Safety Instructions</b>	<b>5</b>
Warranty Information .....	5
Support .....	5
Printing History.....	5
Safety symbols in the manual .....	6
Safety instructions for all DEWETRON DAQ boards.....	7
Environmental Considerations .....	8
Product End-of-Life Handling .....	8
System and Components Recycling .....	8
Restriction of Hazardous Substances .....	8
<b>DEWE-ORION-1622-10x</b>	<b>9</b>
1 Introduction .....	9
1.1 Key features.....	9
1.2 How to use the manual .....	9
1.3 Overview .....	9
1.4 Requirements for using the DEWE-ORION-1622-10x .....	10
1.5 Unpacking .....	10
2 Using DEWE-ORION-1622-10x .....	11
2.1 Hardware installation .....	11
2.2 Software installation .....	12
2.2.1 DEWESoft installation .....	12
2.3 Connecting signals .....	15
2.3.1 Naming .....	15
2.3.2 Connectors .....	16
2.3.2.1 Connector base board .....	16
2.3.2.2 Adapters for base board .....	16
2.3.2.3 Connectors for TTL counter expansion: .....	17
2.3.2.4 Signal connection for TTL counter expansion .....	18
2.3.2.5 Connectors for adjustable counter expansion .....	20
2.3.2.6 Adapters for adjustable counter expansion .....	20
2.3.2.7 Connectors for analog expansion .....	22
2.3.2.8 Connection of CAN interface .....	22
2.3.2.9 Internal synchronisation connector .....	23
2.4 Analog signals.....	24
2.5 Counter and digital I/O .....	25
2.5.1 General functionality .....	25
2.5.1.1 DEWESoft settings .....	26
2.5.2 Basic counter organisation .....	26
2.5.3 Counter and DI/O DEWE-ORION-1622-100/101 .....	27
2.5.4 Counter and DI/O DEWE-ORION-1622-102/103 .....	28
2.5.5 Counter and DI/O DEWE-ORION-1622-104/105 .....	29
2.6 Clock and trigger I/O .....	31
2.7 CAN interface .....	33
2.8 RS-485 interface .....	33
2.9 Synchronizing multiple devices .....	34
2.9.1 Internal synchronisation .....	34
2.9.2 Synchronising multiple systems .....	35
2.9.3 Defining the board order .....	36

# Table of content

---

3	Theory of operation .....	38
3.1	Analog Input.....	38
3.1.1	Functional overview .....	38
3.1.2	Analog input configuration .....	38
3.1.3	Analog to digital conversion .....	39
3.1.4	Anti-alias filter .....	39
3.1.5	Sample clock selection.....	41
3.1.6	Output data format .....	42
3.1.7	Calibration .....	42
3.2	Counter input .....	43
3.2.1	Counter applications.....	43
3.2.1.1	Event Counting .....	43
3.2.1.2	Gated Event Counting .....	44
3.2.1.3	Up/Down Counter .....	45
3.2.1.4	Period Time Measurement.....	46
3.2.1.5	Pulse Width Measurement.....	46
3.2.1.6	Two Pulse Edge Separation Measurement.....	47
3.2.1.7	Motion Encoder .....	48
3.2.1.8	Quadrature Encoder .....	49
3.2.1.9	A-Up/B-Down Encoder .....	51
3.2.1.10	Frequency Measurement.....	52
3.2.2	Miscellaneous counter functions .....	54
3.2.2.1	Filters.....	54
3.2.2.2	Reset on start measure .....	55
3.2.2.3	Count Direction .....	55
3.2.2.4	No new value available .....	55
4	Specifications .....	56
4.1	Analog input.....	56
4.2	Digital and Counter input .....	59
4.3	Digital and clock divider output.....	60
4.4	CAN interface .....	60
4.5	Power requirements .....	60
4.6	General Specifications .....	61
	<b>CE-Certificate of conformity</b> .....	<b>C1</b>

The information contained in this document is subject to change without notice.

DEWETRON elektronische Messgeraete Ges.m.b.H. (DEWETRON) shall not be liable for any errors contained in this document. DEWETRON MAKES NO WARRANTIES OF ANY KIND WITH REGARD TO THIS DOCUMENT, WHETHER EXPRESS OR IMPLIED. DEWETRON SPECIFICALLY DISCLAIMS THE IMPLIED WARRANTIES OF MERCHANTABILITY AND FITNESS FOR A PARTICULAR PURPOSE. DEWETRON shall not be liable for any direct, indirect, special, incidental, or consequential damages, whether based on contract, tort, or any other legal theory, in connection with the furnishing of this document or the use of the information in this document.

## Warranty Information

A copy of the specific warranty terms applicable to your DEWETRON product and replacement parts can be obtained from your local sales and service office.

## Support

For any support please contact your local distributor first or DEWETRON directly.

For Asia and Europe, please contact:

DEWETRON Ges.m.b.H.  
Parkring 4  
A-8074 Graz-Grambach  
AUSTRIA  
Tel.: +43 316 3070  
Fax: +43 316 307090  
Email: [support@dewetron.com](mailto:support@dewetron.com)  
Web: <http://www.dewetron.com>

The telephone hotline is available  
Monday to Friday between  
08:00 and 17:00 CET (GMT +1:00)

For the Americas, please contact:

DEWETRON, Inc.  
10 High Street, Suite K  
Wakefield, RI 02879  
U.S.A.  
Tel.: +1 401 284 3750  
Toll-free: +1 877 431 5166  
Fax: +1 401 284 3755  
Email: [support@dewamerica.com](mailto:support@dewamerica.com)  
Web: <http://www.dewamerica.com>

The telephone hotline is available  
Monday to Friday between  
08:00 and 17:00 GST (GMT -5:00)

## Restricted Rights Legend

Use austrian law for duplication or disclosure.

DEWETRON GesmbH  
Parkring 4  
A-8074 Graz-Grambach / Austria

## Printing History

Please refer to the page bottom for printing version.

Copyright 2005 © DEWETRON elektronische Messgeraete Ges.m.b.H.

This document contains information which is protected by copyright. All rights are reserved. Reproduction, adaptation, or translation without prior written permission is prohibited, except as allowed under the copyright laws.

All trademarks and registered trademarks are acknowledged to be the property of their owners.

# Safety instructions

---

## Safety symbols in the manual

---



*Indicates hazardous voltages.*

---

**WARNING** *Calls attention to a procedure, practice, or condition that could cause bodily injury or death.*

---

**CAUTION** *Calls attention to a procedure, practice, or condition that could possibly cause damage to equipment or permanent loss of data.*

---

### **WARNINGS**

*The following general safety precautions must be observed during all phases of operation, service, and repair of this product. Failure to comply with these precautions or with specific warnings elsewhere in this manual violates safety standards of design, manufacture, and intended use of the product. DEWETRON Elektronische Messgeraete Ges.m.b.H. assumes no liability for the customer's failure to comply with these requirements.*

---

**All accessories shown in this document are available as option and will not be shipped as standard parts.**

## Safety instructions for all DEWETRON DAQ boards

- The DEWETRON data acquisition boards may only be installed by experts.
- Read your manual before operating the board.
- Observe local laws when using the board.
- DO NOT operate the product in an explosive atmosphere or in the presence of flammable gases or fumes.
- DO NOT operate damaged equipment: Whenever it is possible that the safety protection features built into this product have been impaired, either through physical damage, excessive moisture, or any other reason, REMOVE POWER and do not use the product until safe operation can be verified by service-trained personnel. If necessary, return the product to a DEWETRON sales and service office for service and repair to ensure that safety features are maintained.
- Keep away from live circuits: Operating personnel must not remove equipment covers or shields. Procedures involving the removal of covers or shields are for use by service-trained personnel only. Under certain conditions, dangerous voltages may exist even with the equipment switched off. To avoid dangerous electrical shock, DO NOT perform procedures involving cover or shield removal unless you are qualified to do so.
- DO NOT try to service or adjust the board.
- DO NOT substitute parts or modify equipment.
- Before opening the instrument or computer (experts only) disconnect power!
- Don't touch internal wiring (electrostatic damage is possible).
- Don't use higher supply voltage than specified!
- Use only original plugs and cables for harnessing.
- Safety of the operator and the unit depend on following these rules.
- Using the board for medical applications only at owner's risk

# General System Information

---

## Environmental Considerations

Information about the environmental impact of the product.

### Product End-of-Life Handling

Observe the following guidelines when recycling a DEWETRON system:

### System and Components Recycling

Production of this components required the extraction and use of natural resources. The substances contained in the system could be harmful to your health and to the environment if the system is improperly handled at it's end of life! Please recycle this product in an appropriate way to avoid an unnecessary pollution of the environment and to keep natural resources.



This symbol indicates that this system complies with the European Union's requirements according to Directive 2002/96/EC on waste electrical and electronic equipment (WEEE). Please find further informations about recycling on the DEWETRON web site [www.dewetron.com](http://www.dewetron.com)



### Restriction of Hazardous Substances

This product has been classified as Monitoring and Control equipment, and is outside the scope of the 2002/95/EC RoHS Directive. This product is known to contain lead.

## 1 Introduction

### 1.1 Key features

- 16 simultaneous sampled channels
- 102.4 kS/s per channel
- 22-bit resolution
- Anti-aliasing filter
- High dynamic range 102 dB
- Single ended inputs with remote sense
- Two 32-bit synchronous counter/encoder
- 8 synchronous digital inputs with TTL level
- 8 digital in- and outputs with TTL level
- RS-485 interface



#### Options:

- Two high speed CAN 2.0B controllers
- 16 additional analog/digital inputs (ORION-3222-100)
- 8 additional counter/encoder or 32 TTL inputs (ORION-1622-102)
- 8 additional counter/encoder or 32 inputs adjustable trigger levels (ORION-1622-104)

### 1.2 How to use the manual

- In Chapter one you find an overview about the card-types and possibilities of configurations.
- Chapter two explains how to install the card and connect the sensors.
- The ADC conversion and the counter-functions are described in chapter three.
- All specifications are listed in chapter four.

### 1.3 Overview

The DEWE-ORION-1622-10x combines high resolution (22-bit) with high speed (102.4 kS/s per channel) and high accuracy (typical 0.002 dB inter channel gain mismatch). All this has been arranged on a PCI half-size board. In addition each channel has an anti-aliasing filter which is automatically set to the half of the sample frequency. This can be reached with an internal oversampling of the ADC of up to 256 times. That means if the sample frequency is set to 50 kHz, the ADC converts data with 12.8 MHz!

Due to the multiple board synchronisation features it is possible to install up to 8 DEWE-ORION-1622-10x boards in one system working absolutely synchronous. Using more than 8 boards (in an external system or connected with a PCI to PCI-Bridge to the main system) requires the usage of a SYNCH-BUS-REPEATER (option ORION-DSA-SYNC).

This high channel count, combined with high sample rate, requires a high speed and high capacity data storing system behind the boards. For example: 128 channels, each with 102.4 kHz sample rate and 22-bit resolution results in nearly 50 Mbyte of data per second (22-bit data will be transferred as a 32-bit value). To reduce this by a factor of two, a unique 16-bit data transfer mode (packed mode) is implemented. It is no simple reduction to 16-bit resolution. The technique picks the 16 bits of interest out of the whole 22-bit analog range for the data transfer.

The board is also equipped with 16 digital inputs where 8 of them can be also used as digital outputs. Two onboard counter/encoder support the unique advanced counter mode allowing counting and frequency measurement with just one counter input. The onboard RS-485 interface controls DEWETRON signal conditioning amplifiers and can directly acquire data from PAD/EPAD series modules.

For guaranteed synchronous data acquisition with the analog inputs, the DEWE-ORION-1622-10x offers 2 high speed CAN interface channels as an option. The boards can be expanded with 16 additional analog/digital inputs or 8 additional 32-bit counter/encoder channels.

# DEWE-ORION-1622-10x

Model	Analog input channels	Max. sampling rate / channel	Digital input channels	Digital I/O	Ext. Clock	Ext. Trigger	Counter Encoder TTL	Counter Encoder ADJ	CAN
DEWE-ORION-1622-100	16	102.4 kS/s	2 (8*)	8	-	1	2	-	-
DEWE-ORION-1622-101	16	102.4 kS/s	2 (8*)	8	-	1	2	-	2
DEWE-ORION-1622-102	16	102.4 kS/s	10 (40*)	8	-	1	2 + 8	-	-
DEWE-ORION-1622-103	16	102.4 kS/s	10 (40*)	8	-	1	2 + 8	-	2
DEWE-ORION-1622-104	16	102.4 kS/s	10 (40*)	8	-	1	2	8	-
DEWE-ORION-1622-105	16	102.4 kS/s	10 (40*)	8	-	1	2	8	2
DEWE-ORION-3222-100	32	102.4 kS/s	18 (24*)	8	1	1	2	-	-
DEWE-ORION-3222-101	32	102.4 kS/s	18 (24*)	8	1	1	2	-	2

\* Without using counter inputs

## Options:



Built-in digital I/O and counter/encoder connectors

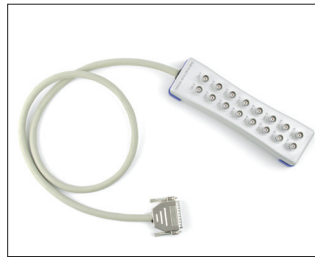

ORION-1622-CB16-BNC  
16 channel connector box for easy sensor connection



ORION-CB-CNT8 connection box for easy sensor connection



DEWE-CAN-CAB-2  
2 channel CAN adaptor

## 1.4 Requirements for using the DEWE-ORION-1622-10x

To install and use the DEWE-ORION-1622-10x device you need:

- PC with one free PCI slot
- WINDOWS 2000 or XP operating system
- DEWE-ORION-1622-10x board
- DEWE-ORION-1622-10x Technical Reference Manual (shipped with the board or available on [www.dewetron.com](http://www.dewetron.com) or [ftp.dewetron.com](ftp://ftp.dewetron.com))
- Device driver (shipped with the board)

Recommended options (not shipped with the board):

- Signal connection (e.g. BNC connector box ORION-CB16-BNC)
- DEWESoft 6.5.2 (or higher) or other application software

## 1.5 Unpacking

Transport and store the DEWE-ORION-1622-10x in the antistatic plastic package (ESD packaging), where it was originally packed in. Otherwise the device may be damaged by electrostatic discharge. The unpacking and the mounting in your computer should be done in an electrostatic protected area. Don't touch the exposed pins of the connectors! Inspect the device for loose components or other sign of damage before mounting it. Don't install a damaged device into your computer.

## 2 Using DEWE-ORION-1622-10x

### 2.1 Hardware installation

Shut down your computer and remove power. Install the board into your computer in correspondence with the instructions in your PC manual. When you have finished the hardware installation and boot up your computer, the operating system will alert that it found a new hardware. Cancel the windows hardware-driver wizard.

Insert the DEWE-System DVD shipped together with the board into your DVD drive (for example D:\) and start the following executable file: D:\Install\Drivers\16\_DaqBoards\Dewetron\OrionDAQ\OrionSetup.exe. After the installation you have to reboot the system.

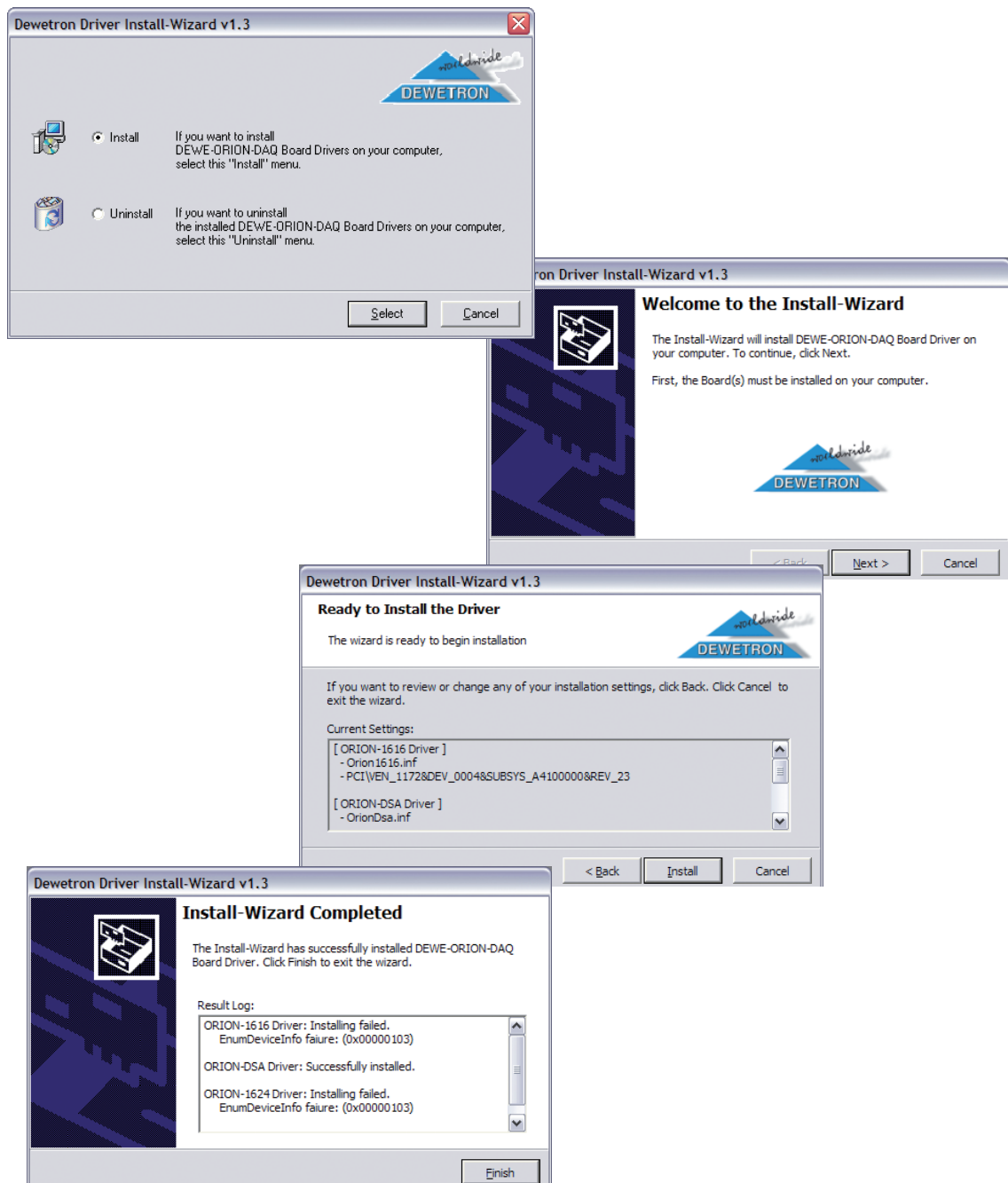

# DEWE-ORION-1622-10x

## 2.2 Software installation

### 2.2.1 DEWESoft installation

If the installation software doesn't start when you insert the DEWE-System DVD into the computer, start it manually by clicking on the **ShelExec.exe** file on the DVD or navigate to "HTML" and start the **index.html**. Follow the instructions of the installer.

The screenshots show the following navigation path:

- DEWETRON System DVD**: Main menu with categories: DRIVER, SOFTWARE, TOOLS, MANUALS, VIDEOS, BROWSE. Version information: Version: 7.0.3\_e, Released: 08/2011.
- DEWESoft**: Sub-menu under SOFTWARE with categories: DEWESoft, DEWETrans, TOOLS, MANUALS, VIDEOS, BROWSE.
- DEWESoft 7**: Sub-menu under DEWESoft with categories: DEWESoft 7, DEWESoft 6, DEWESoft Manuals.
- Index von file:///file:/SystemDVD/System DVD/Install/Software/DEWESoft7**: File list showing the target file **DEWESoft\_FULL\_7\_0\_3.exe**.

Name	Größe	Zuletzt verändert
DEWESoft_FULL_7_0_3.exe	134118 KB	28.02.2011 08:13:52
PlugIn_BatMan		09.11.2010 17:48:44
PlugIn_CPAD2		21.12.2010 10:10:50
PlugIn_EPAD-BASE-2		22.11.2010 14:47:54

# DEWE-ORION-1622-10x

The install shield wizard will simplify the installing procedure.

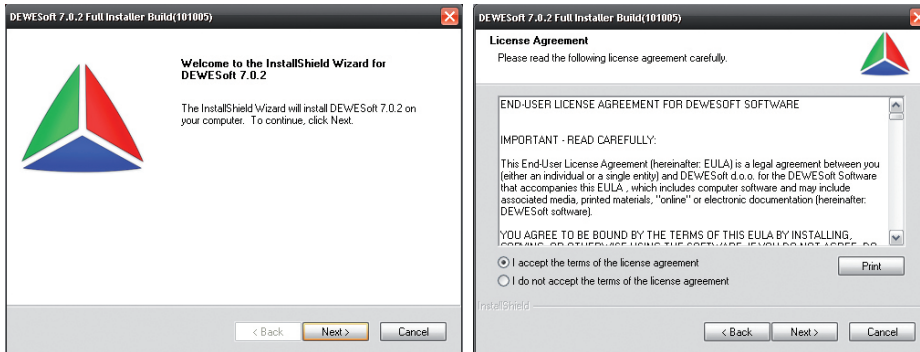

Select the needed options you want to install and enter your information.

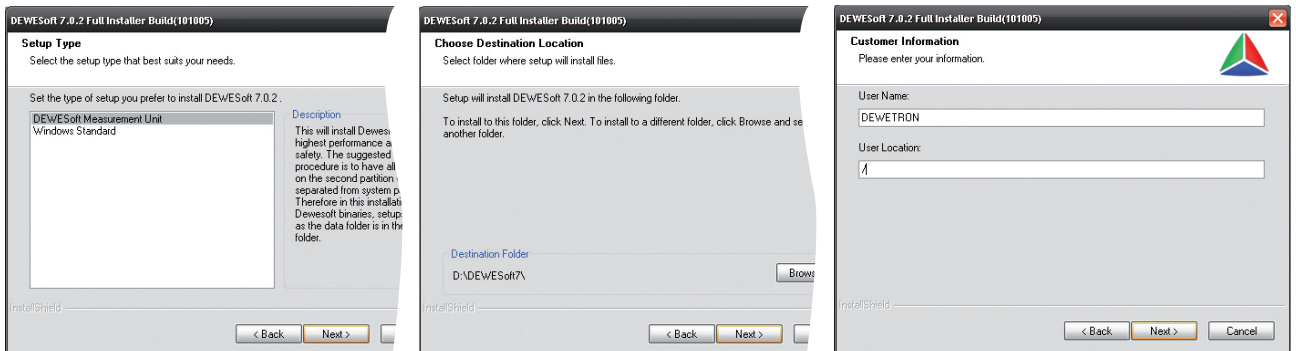

Select the features you want to install and start the installation.

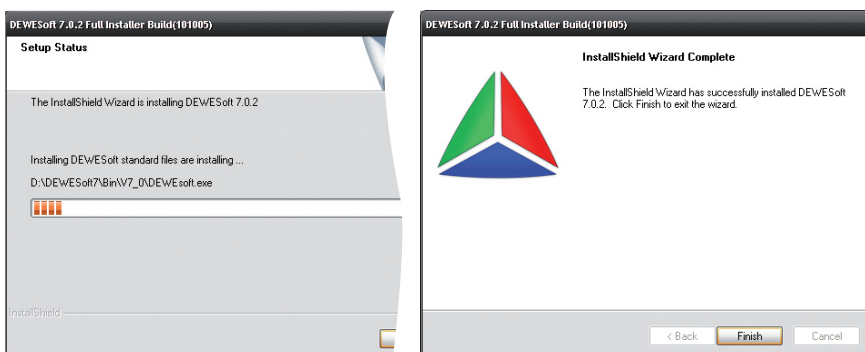
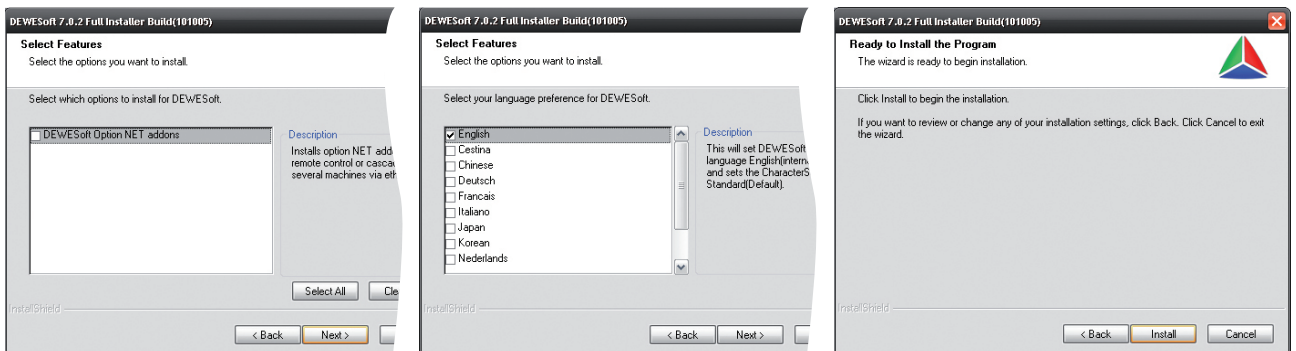

# DEWE-ORION-1622-10x

Now DEWESoft is installed on your computer. The software creates some directories on your harddisk. You can start the software in the Windows start menu or use the icon created on your desktop. For more information about the DEWESoft installation please refer to the *DEWESoft Software Users Manual*.

To modify the hardware settings, select System - Hardware setup in the menu. Select **DEWETRON DSA** as analog device.

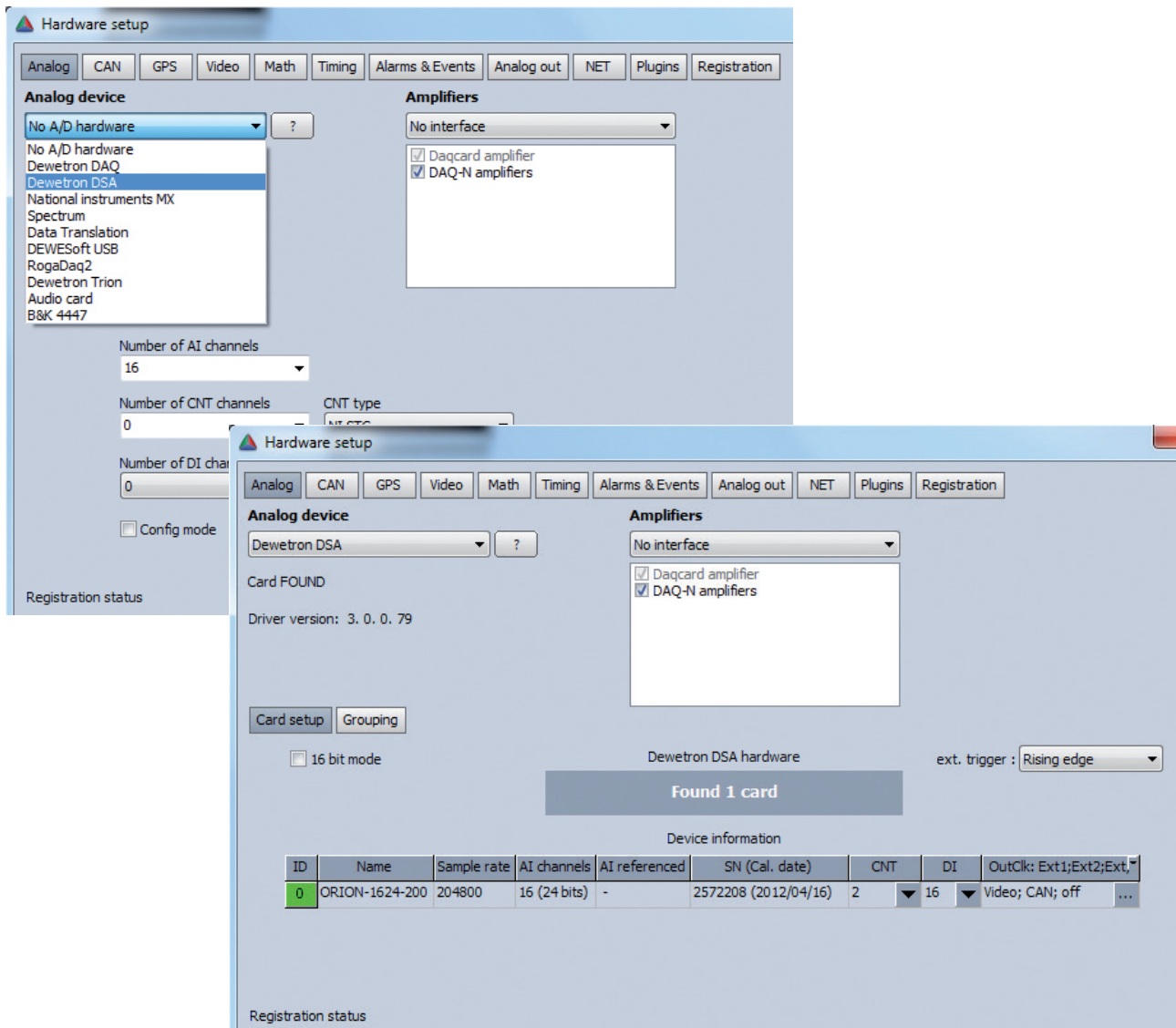

## 2.3 Connecting signals

### 2.3.1 Naming

In multiple board systems a clear defined channel name structure is important to avoid inconstancy in the channel connection. Usually analog input channels are just named in a row. Therefore at a 3 board system the channels are named from CH 0 to CH 47. Due to the flexible structure of the digital and counter inputs the naming in a row is not possible. That's why each input at the ORION base board (code letter B) and also at the expansion board (code letter E) gets a channel prefix name like shown in the example below for a two board system.

Following block diagram explains the naming:

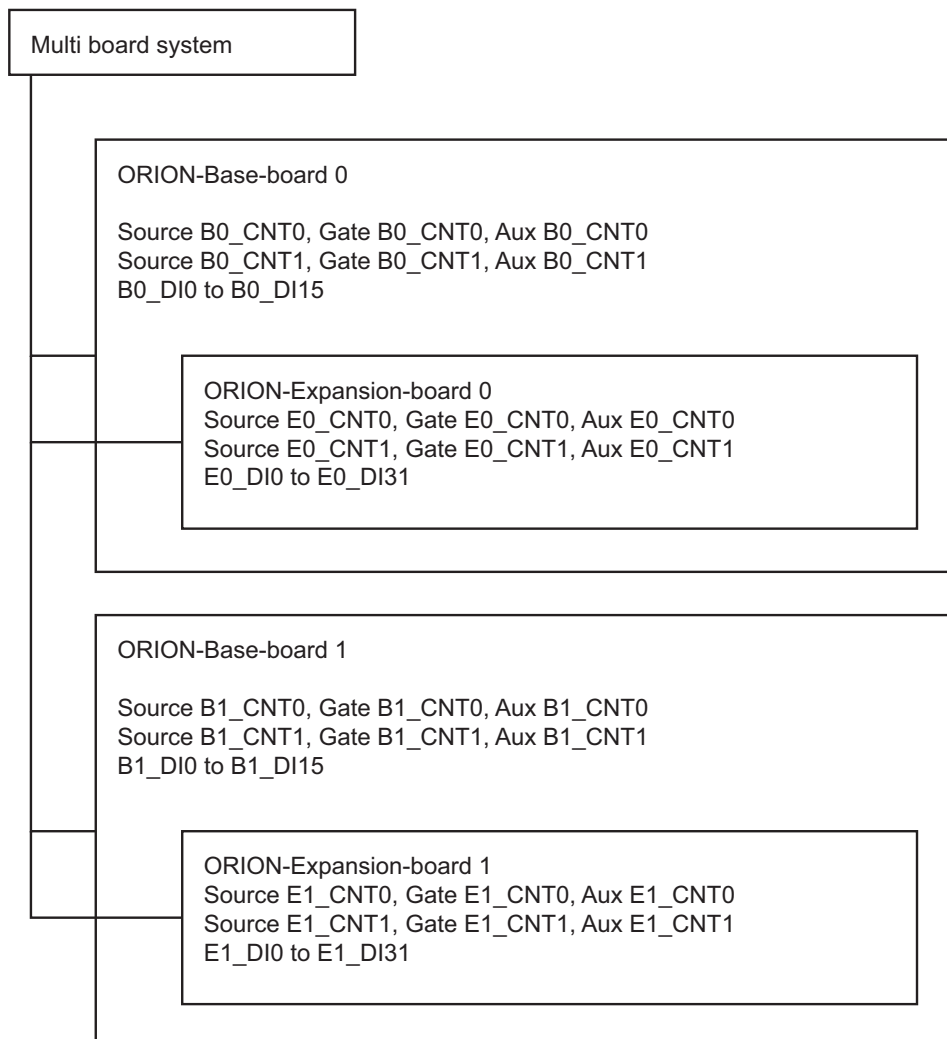

Source B0\_CNT0: Is the source input of CNT0 on ORION-Base-board 0

E1\_DI5: Is the fifth digital input on ORION-Expansion-board 1

# DEWE-ORION-1622-10x

## 2.3.2 Connectors

### 2.3.2.1 Connector base board

The schematic shows the pin assignment of the input connector. A standard 68-pin high density female type with 0.05 inch pin distance can be used for the signal connection.

The ±15 V output is able to supply up to 50 mA (2 W). The supply is protected against short circuits. Overloading this output may cause an overheating of the DEWE-ORION-1622-10x and lowers the signal quality. The +5 V output can supply up to 500 mA.

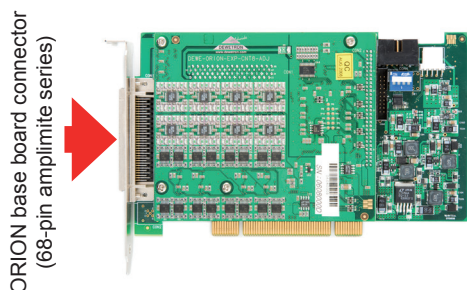

Digital Input				Digital Input
-	+15AV	35 == 1	-15AV	-
-	AGND	36 == 2	AGND	-
-	AGND	37 == 3	AGND	-
-	AGND	38 == 4	CH15+	-
-	AGND	39 == 5	CH14+	-
-	AGND	40 == 6	CH13+	-
-	AGND	41 == 7	CH12+	-
-	AGND	42 == 8	CH11+	-
-	AGND	43 == 9	CH10+	-
-	AGND	44 == 10	CH9+	-
-	AISENSE2	45 == 11	CH8+	-
-	AGND	46 == 12	CH7+	-
-	AGND	47 == 13	CH6+	-
-	AGND	48 == 14	CH5+	-
-	AGND	49 == 15	CH4+	-
-	AGND	50 == 16	CH3+	-
-	AGND	51 == 17	CH2+	-
-	AGND	52 == 18	CH1+	-
-	AISENSE1	53 == 19	CH0+	-
-	AGND	54 == 20	AGND	-
Bx_DI 8	Bx_DO 0	55 == 21	Source Bx_CNT0	Bx_DI 0
Bx_DI 9	Bx_DO 1	56 == 22	Gate Bx_CNT0	Bx_DI 1
Bx_DI 10	Bx_DO 2	57 == 23	Aux Bx_CNT0	Bx_DI 2
Bx_DI 11	Bx_DO 3	58 == 24	Source Bx_CNT1	Bx_DI 3
Bx_DI 12	Bx_DO 4	59 == 25	Gate Bx_CNT1	Bx_DI 4
Bx_DI 13	Bx_DO 5	60 == 26	Aux Bx_CNT1	Bx_DI 5
Bx_DI 14	Bx_DO 6	61 == 27	RS-485A	-
Bx_DI 15	Bx_DO 7	62 == 28	RS-485B	-
-	+5DV	63 == 29	-	Bx_DI 6
-	DGND	64 == 30	-	Bx_DI 7
-	DGND	65 == 31	EXT_CLK	-
-	+5DV	66 == 32	EXT_Trigger	-
-	DGND	67 == 33	EXT_CLK1	-
-	DGND	68 == 34	EXT_CLK2	-

68-pin Amplimite series  
(AMP: 174339-5) SCSI II

### 2.3.2.2 Adapters for base board

For easy access to the digital and counter inputs DEWETRON instruments are equipped with a DB37 connector for board 0. Also all hardware synchronisation signals (for example clocking the camera, synchronisation external 3rd party hardware, external trigger...) are available on this connector

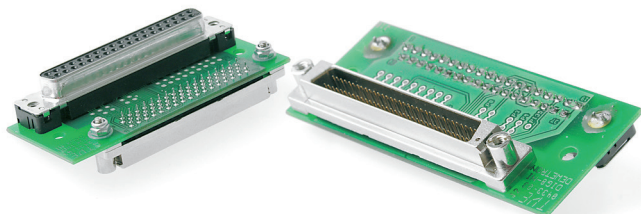

Digital Input	Counter Input		Counter Input	Digital Input	
Bx_DI 8	Bx_DO 0	1 ●	●20	DGND	-
Bx_DI 9	Bx_DO 1	2 ●	●21	DGND	-
Bx_DI 10	Bx_DO 2	3 ●	●22	DGND	-
Bx_DI 11	Bx_DO 3	4 ●	●23	DGND	-
Bx_DI 12	Bx_DO 4	5 ●	●24	DGND	-
Bx_DI 13	Bx_DO 5	6 ●	●25	DGND	-
Bx_DI 14	Bx_DO 6	7 ●	●26	DGND	-
Bx_DI 15	Bx_DO 7	8 ●	●27	DGND	-
-	EXT_CLK	9 ●	●28	DGND	-
-	RS-485A	10 ●	●29	RS-485B	-
-	EXT_Trigger	11 ●	●30	DGND	-
Bx_DI 0	Source Bx_CNT0	12 ●	●31	Gate Bx_CNT1	Bx_DI 4
Bx_DI 1	Gate Bx_CNT0	13 ●	●32	Aux Bx_CNT1	Bx_DI 5
-	EXT_CLK2	14 ●	●33	-	Bx_DI 6
Bx_DI 2	Aux Bx_CNT0	15 ●	●34	-	Bx_DI 7
Bx_DI 3	Source Bx_CNT1	16 ●	●35	RES.*	-
-	EXT_CLK1	17 ●	●36	DGND	-
-	+5 DV	18 ●	●37	DGND	-
-	+5 DV	19 ●			

37-pin SUB-D connector

# DEWE-ORION-1622-10x

## Optional ORION-CNT2-LEMO

As an option (ORION-CNT2-LEMO) the two counters can be also wired to a 7-pin female lemo connector for direct connection of encoders or any other counter channel source.

- 1: Source Bx\_CNT(n)
  - 2: Aux\_Bx\_CNT(n)
  - 3: Gate Bx\_CNT(n)
  - 4: Power GND
  - 5: +5 V (max. 500 mA)
  - 6: +12 V (max. 500 mA)
  - 7: Signal GND
- n .. channels 0 to 1 of counter board

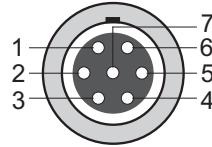

7-pin female LEMO connector  
EGG1B307CLL

## Optional ORION-BASE-DI-ISO

Some applications require isolated digital inputs. This can be achieved with the option ORION-BASE-DI-ISO. All inputs are isolated from the input to the ORION board but also isolated between each other.

\*) 12V only available on instruments! N.c. on DEWE-5x-PCI-xx expansion systems.

Digital Input      Counter Input

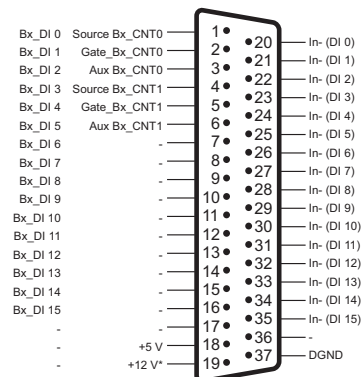

### 2.3.2.3 Connectors for TTL counter expansion:

The DEWE-ORION-1622-100 can be expanded with 8 additional counters or 32 digital inputs with TTL input level. These boards are named with

DEWE-ORION-1622-102 (without CAN) or  
DEWE-ORION-1622-103 (with CAN)

The pin assignment is shown in the schematic:

ORION expansion board connector  
(68-pin amplimite series)

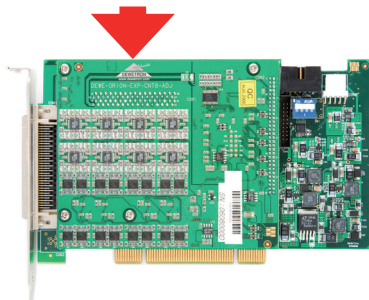

Counter expansion

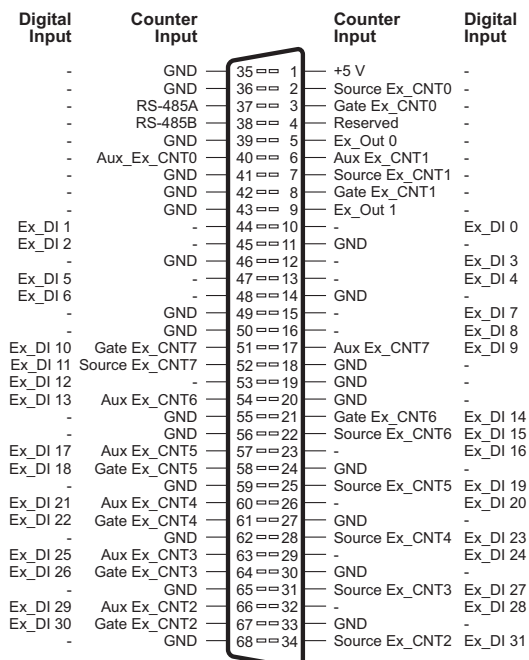

Digital expansion Ex  
68-pin Amplimite series  
(AMP: 174339-5) SCSI II

# DEWE-ORION-1622-10x

## 2.3.2.4 Signal connection for TTL counter expansion

Without any option the counter or digital inputs are wired to a 68 pin female connector on DEWETRON instruments. An easy sensor connection possibility is given with ORION-CB-CNT8 connection box. For direct connection of the sensor to the instrument various options for counter panels are available:

### ORION-DIO-PANEL-1

These panels should be used if mainly counter/encoder signals will be measured. All eight counters are wired to 7-pin Lemo connectors and Ex\_DI 0 to Ex\_DI 15 are connected to a DB37.

### ORION-DIO-PANEL-2

All 32 digital inputs are wired to two DB37 connectors. Ex\_CNT 0 and Ex\_CNT 1 are connected to a 7-pin Lemo. Therefore this panel is suitable if mainly standard digital inputs are requested.

### ORION-DIO-PANEL-3

This option is similar to Panel-2 except the digital inputs are galvanically isolated. The two counter inputs are not isolated.

### Non isolated DB37 pinout for ORION-DIO-PANEL-1 and ORION-DIO-PANEL-2:

**Digital Input**      **Counter Input**

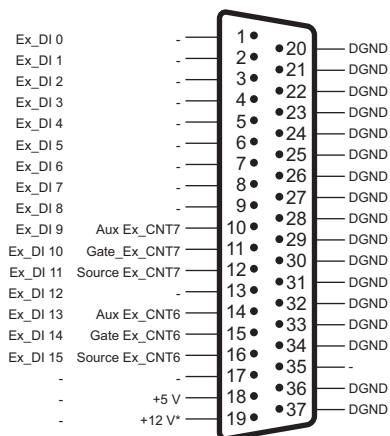

Ex\_DI0 .. DI15  
37-pin female SUB-D connector

**Digital Input**      **Counter Input**

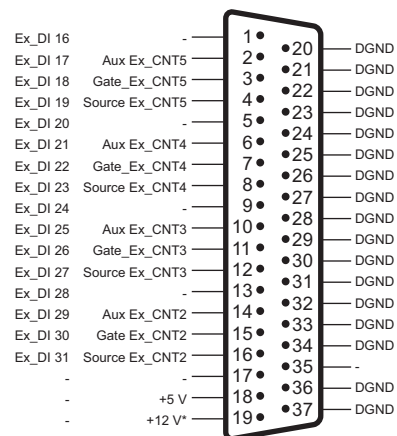

Ex\_DI16 .. DI31  
37-pin female SUB-D connector

\*) 12V only available on instruments! N.c. on DEWE-5x-PCI-xx expansion systems.

## Isolated DB37 pinout for ORION-DIO-PANEL-3

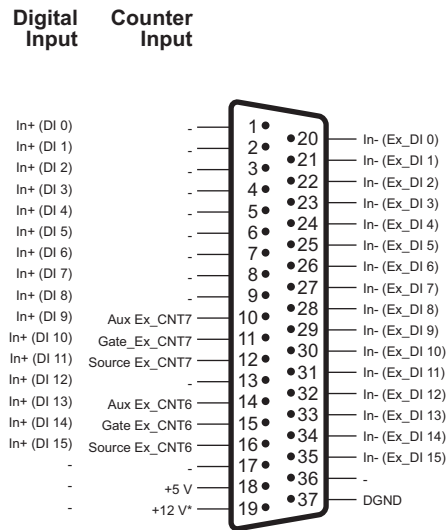

*Ex\_DI0 .. DI15*

*37-pin female SUB-D connector*

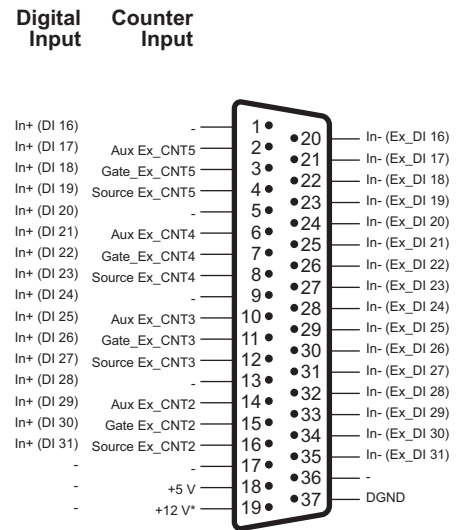

*Ex\_DI16 .. DI31*

*37-pin female SUB-D connector*

\*) 12V only available on instruments! N.c. on DEWE-5x-PCI-xx expansion systems.

## Counter/Encoder connector for all panel options

- 1: Source Ex\_CNT(n)
  - 2: Aux\_Ex\_CNT(n)
  - 3: Gate Ex\_CNT(n)
  - 4: Power GND
  - 5: +5 V (max. 500 mA)
  - 6: +12 V (max. 500 mA)
  - 7: Signal GND
- n .. channels 0 to 1 of counter board

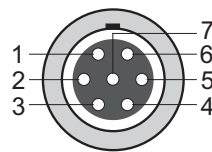

*7-pin female LEMO connector  
EGG1B307CLL*

# DEWE-ORION-1622-10x

## 2.3.2.5 Connectors for adjustable counter expansion

The DEWE-ORION-1622-100 can be expanded with 8 additional counters or 32 digital inputs with differential input, adjustable trigger inputs and programmable AC/DC coupling. These boards are named with

DEWE-ORION-1622-104 (without CAN) or DEWE-ORION-1622-105 (with CAN)

The pin assignment is shown in the schematic:

ORION expansion board connector  
(68-pin amplimite series)

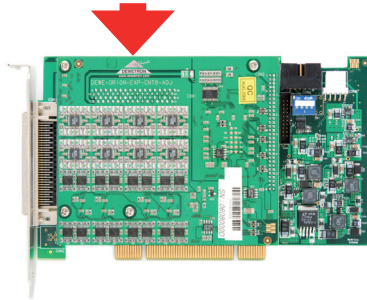

Counter expansion

Digital Input	Counter Input	Counter Input	Counter Input	Digital Input
-	GND	35 == 1	+5 V	-
-	In- Ex_CNT0	36 == 2	Source Ex_CNT0	-
-	RS-485A	37 == 3	Gate Ex_CNT0	-
-	RS-485B	38 == 4	Reserved	-
-	GND	39 == 5	Ex_Out 0	-
-	Aux_ Ex_CNT0	40 == 6	Aux_ Ex_CNT1	-
-	In- Ex_CNT1	41 == 7	Source Ex_CNT1	-
-	GND	42 == 8	Gate Ex_CNT1	-
-	GND	43 == 9	Ex_Out 1	-
Ex_DI 1	-	44 == 10	-	Ex_DI 0
Ex_DI 2	-	45 == 11	GND	-
-	GND	46 == 12	-	Ex_DI 3
Ex_DI 5	-	47 == 13	-	Ex_DI 4
Ex_DI 6	-	48 == 14	GND	-
-	GND	49 == 15	-	Ex_DI 7
-	GND	50 == 16	-	Ex_DI 8
Ex_DI 10	Gate Ex_CNT7	51 == 17	Aux_ Ex_CNT7	Ex_DI 9
Ex_DI 11	Source Ex_CNT7	52 == 18	In- Ex_CNT7	-
Ex_DI 12	-	53 == 19	GND	-
Ex_DI 13	Aux_ Ex_CNT6	54 == 20	GND	-
-	GND	55 == 21	Gate Ex_CNT6	Ex_DI 14
-	In- Ex_CNT6	56 == 22	Source Ex_CNT6	Ex_DI 15
Ex_DI 17	Aux_ Ex_CNT5	57 == 23	-	Ex_DI 16
Ex_DI 18	Gate Ex_CNT5	58 == 24	GND	-
-	In- Ex_CNT5	59 == 25	Source Ex_CNT5	Ex_DI 19
Ex_DI 21	Aux_ Ex_CNT4	60 == 26	-	Ex_DI 20
Ex_DI 22	Gate Ex_CNT4	61 == 27	GND	-
-	In- Ex_CNT4	62 == 28	Source Ex_CNT4	Ex_DI 23
Ex_DI 25	Aux_ Ex_CNT3	63 == 29	-	Ex_DI 24
Ex_DI 26	Gate Ex_CNT3	64 == 30	GND	-
-	In- Ex_CNT3	65 == 31	Source Ex_CNT3	Ex_DI 27
Ex_DI 29	Aux_ Ex_CNT2	66 == 32	-	Ex_DI 28
Ex_DI 30	Gate Ex_CNT2	67 == 33	GND	-
-	In- Ex_CNT2	68 == 34	Source Ex_CNT2	Ex_DI 31

Digital expansion Ex  
68-pin Amplimite series  
(AMP: 174339-5) SCSI II

## 2.3.2.6 Adapters for adjustable counter expansion

Without any option the counter or digital inputs are wired to a 68 pin female connector on DEWETRON instruments. An easy sensor connection possibility is given with ORION-CB-CNT8 connection box. For direct connection of the sensor to the instrument various options for counter panels are available:

### ORION-DIO-PANEL-1

These panels should be used if mainly counter/encoder signals will be measured. All eight counters are wired to 7-pin Lemo connectors and Ex\_DI 0 to Ex\_DI 15 are connected to a DB37.

### ORION-DIO-PANEL-2

All 32 digital inputs are wired to two DB37 connectors. Ex\_CNT 0 and Ex\_CNT 1 are connected to a 7-pin Lemo. Therefore this panel is suitable if mainly standard digital inputs are requested.

### ORION-DIO-PANEL-3

This option is similar to Panel-2 except the digital inputs are galvanically isolated. The two counter inputs are not isolated.

# DEWE-ORION-1622-10x

## Non isolated DB37 pinout for ORION-DIO-PANEL-1 and ORION-DIO-PANEL-2

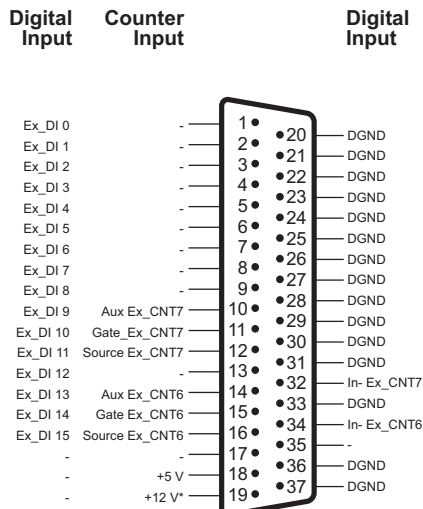

Ex\_DI0 .. DI15

37-pin female SUB-D connector

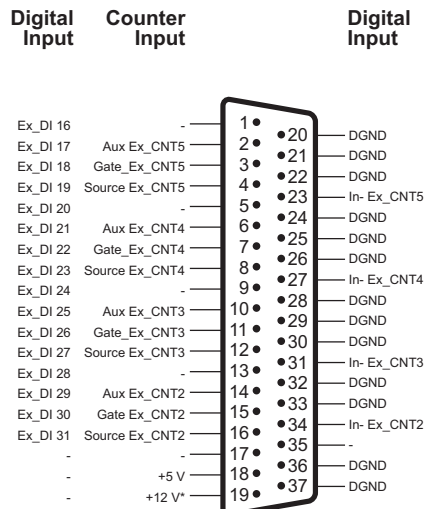

Ex\_DI16 .. DI31

37-pin female SUB-D connector

## Isolated DB37 pinout for ORION-DIO-PANEL-3 (optional)

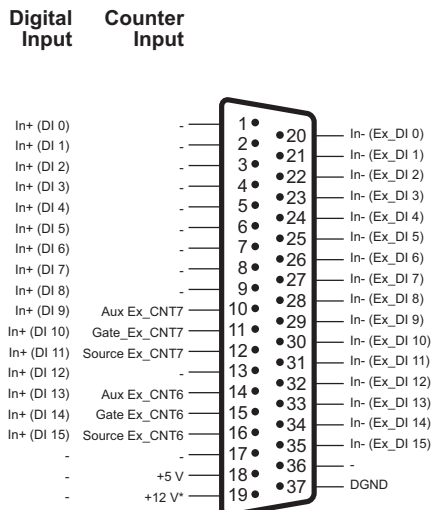

Ex\_DI0 .. DI15

37-pin female SUB-D connector

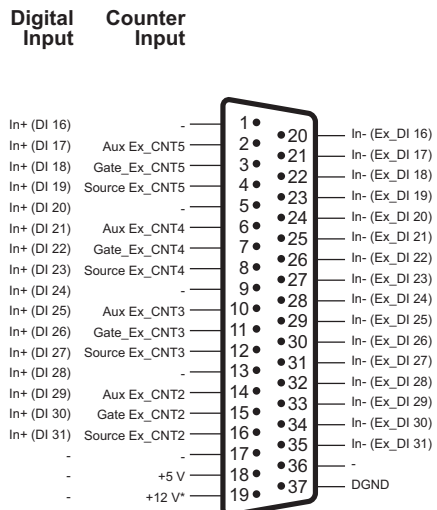

Ex\_DI16 .. DI31

37-pin female SUB-D connector

\*) 12V only available on instruments! N.c. on DEWE-5x-PCI-xx expansion systems.

## Counter/Encoder connector for all panel options

- 1: Source Ex\_CNT(n)
  - 2: Aux\_Ex\_CNT(n)
  - 3: Gate Ex\_CNT(n)
  - 4: Power GND
  - 5: +5 V (max. 500 mA)
  - 6: +12 V (max. 500 mA)
  - 7: In- Ex\_CNT(n)
- n .. channels 0 to 1 of counter board

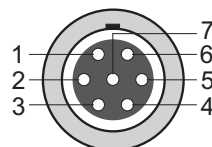

7-pin female LEMO connector  
EGG1B307CLL

# DEWE-ORION-1622-10x

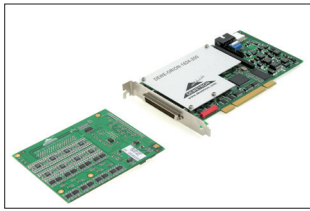

DEWE-ORION-1622-104 with ORION-EXP-CNT8-ADJ board

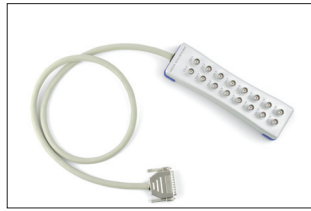

ORION-1622-CB16-BNC 16 channel connector box for easy sensor connection



BOX-ORION-CB-CNT8 for easy sensor connection



DEWE-CAN-CAB-2 2 channel CAN adaptor

## 2.3.2.7 Connectors for analog expansion

The analog expansion connector supports no counter channels. But 16 additional digital input channels are available. The signals EXT\_CLK-Out, EXT\_Trigger-Out, EXT\_CLK1-Out and EXT\_CLK2-Out are always used as output. This is independent of the main board signal direction. These boards are named with:

DEWE-ORION-3222-100 (without CAN) or  
DEWE-ORION-3222-101 (with CAN)

The pin assignment is shown in the schematic:

### Analog expansion

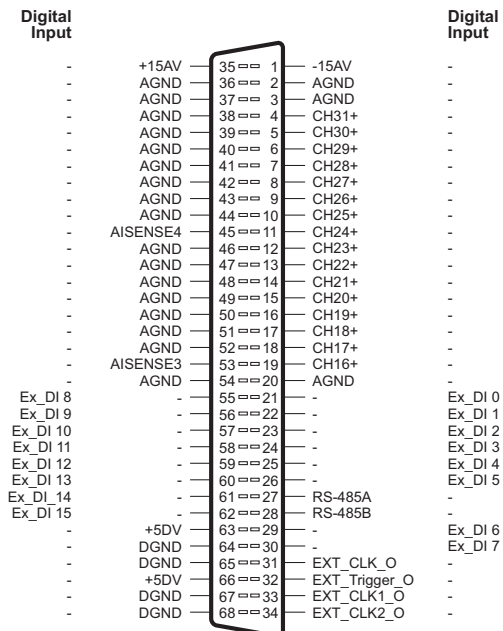

Analog expansion Ex  
68-pin Amplimite series  
(AMP: 174339-5) SCSI II

## 2.3.2.8 Connection of CAN interface

There are two possibilities to connect CAN signals to the board. An adaptor connects the 16-pin Micro Match connector with two 9-pin SUB-D connectors. They are prepared to be mounted inside the system.

Pin assignment of the on-board 16-pin Micro Match connector:

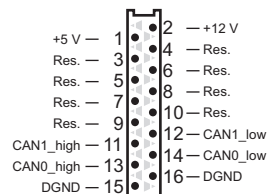
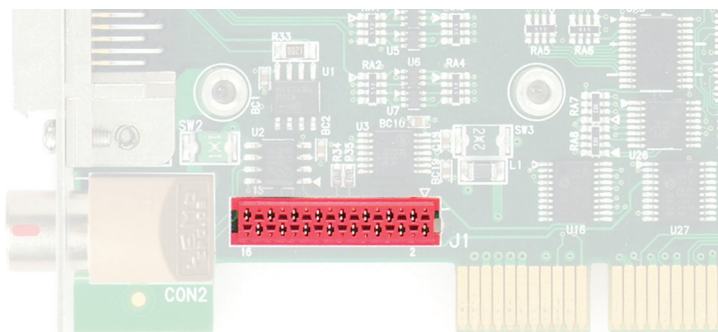

16-pin Micro Match connector

# DEWE-ORION-1622-10x

Pin assignment of the 9-pin connectors on the DB9-adaptor.



Two 9-pin SUB-D connectors prepared to be mounted inside systems

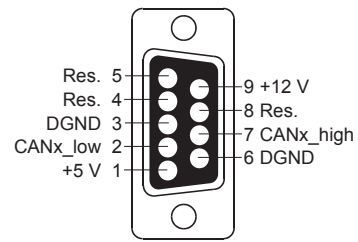

9-pin SUB-D connector male



DEWE-CAN-CAB-2 with two 9-pin SUB-D connectors

Pin assignment of the on-board 7-pin Lemo connector

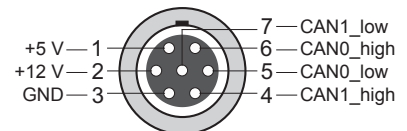
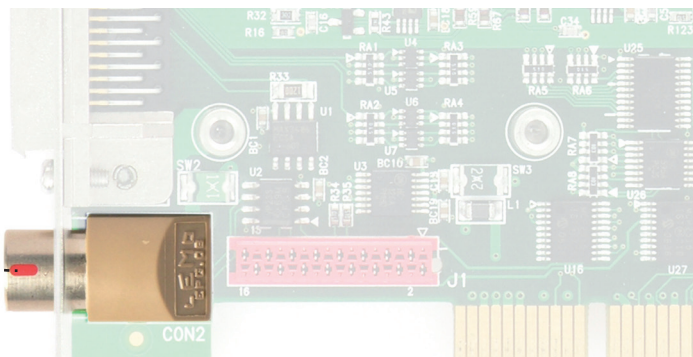

7-pin Lemo connector female  
Type: EPG.0B.307.HLN

## 2.3.2.9 Internal synchronisation connector

For multiple device operation the DEWE-ORION-1622-10x is equipped with an additional synchronization connector. Pin assignment of the on-board 10-pin Synch-connector:

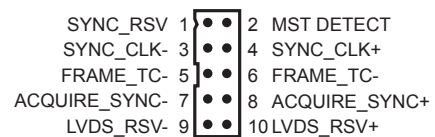
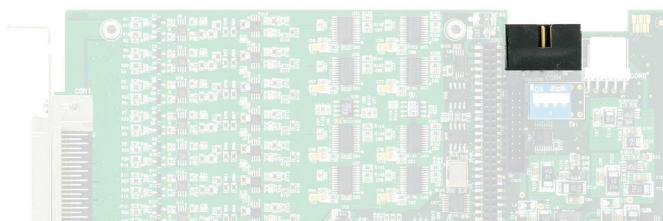

10-pin connector male

# DEWE-ORION-1622-10x

The signal from the 5-pin Molex connector is also available on the analog input connector and can be used for hardware synchronisation of 3rd party measurement hardware.

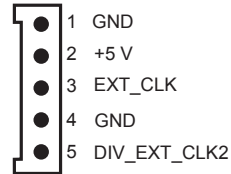
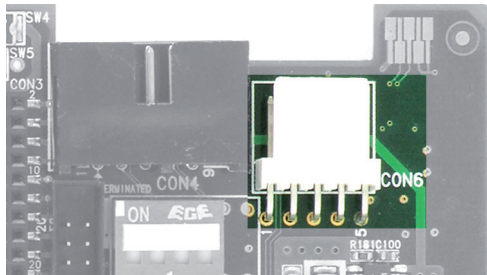

Type: 5-pin CON6 connector (MOLEX KK® series)

## 2.4 Analog signals

The block diagram below (figure 1) gives an idea of the analog input configuration. The DEWE-ORION-1622-10x consists of 16 separate input amplifiers and analog to digital converters.

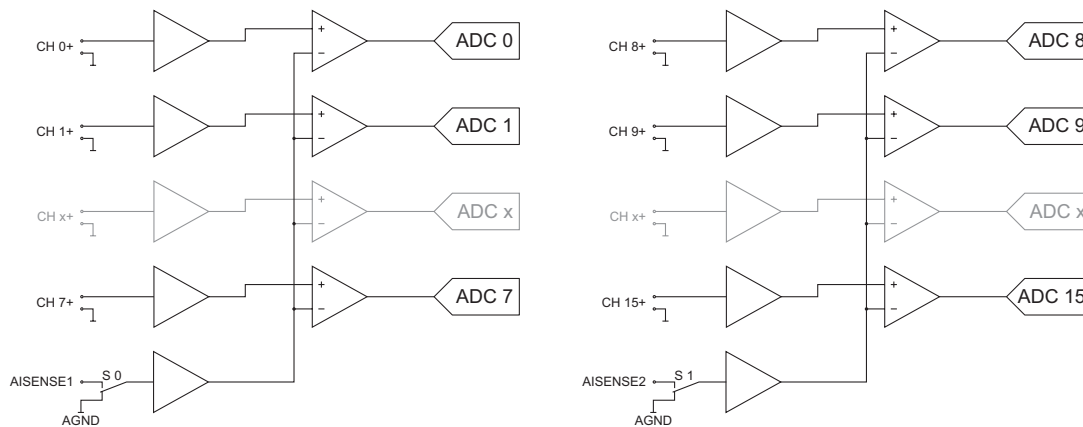

Figure 1: Analog input configuration

The configuration can be changed between single ended (referenced to AGND) and sensed (referenced to sense) mode. The sensed mode is similar to a differential input. The difference to real differential input is that there is just one minus input available in sensed measurement mode. With this technique the influence of ground loops between signal source and the DEWE-ORION-1622-10x can be completely eliminated.

Figure 2 shows the principle of the sensed mode configuration. Usually the level of the signal source is referenced directly to the minus point, which is usually its power supply ground. On the other hand without sensed configuration the DEWE-ORION-1622-10x is also referenced to its power supply ground. Due to the supply current and the line resistance of the signal source and the AD board the ground of both is different. The result of this chain would be an offset error.

# DEWE-ORION-1622-10x

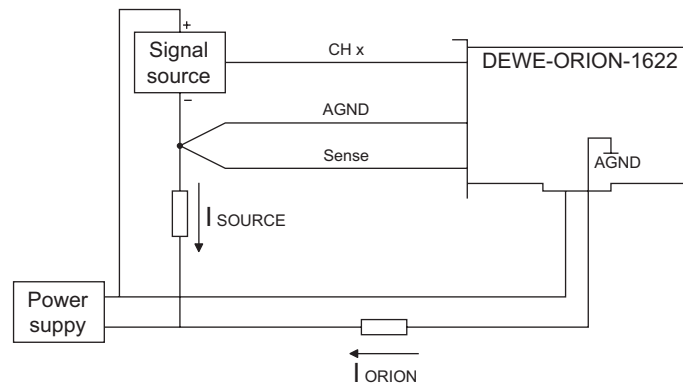

Figure 2: Sensed mode configuration

In the sensed configuration the reference voltage is taken directly at the minus (or power ground) of the sensor to remove this offset error.

*Note: In sensed configuration the input range of all channels have to set to the same value!*

The input voltage range in sensed mode is limited to  $\pm 11.5$  V.

Examples:

Ch x = +11 V, Sense = +7 V, voltage difference = 4 V, result is valid

Ch x = +11 V, Sense = +13 V, voltage difference = -2 V, result is not valid (the input voltage is less than 11.5 V but the sense voltage level (13 V) is higher than the input range).

If you use a customized cable for signal connection, we strongly recommend using twisted pair cables. Although the single ended configuration each channel has to get its own twisted pair with signal and AGND. Otherwise the high channel to channel isolation (channel cross Talk) get lost. Also the high signal to noise ratio can only be guaranteed by using a shielded twisted pair cable to connect the signal sources to the DEWE-ORION-1622-10x.

The analog input structure of the analog expansion board (DEWE-ORION-3222-10x) is absolute identical to the structure of the main board.

## 2.5 Counter and digital I/O

### 2.5.1 General functionality

The DEWE-ORION-1622-10x is also suited with synchronous 32-bit advanced counters and digital inputs. The flexible signal routing allows easy signal connection and the usage of the same input pin for all counter input functions and for digital inputs. Some pins also can be used for digital output. In addition to the basic counter function like simple event counting, up/down counting and gated event counting also period time, pulse width, two-edge separation, frequency and all encoder measurements are supported.

# DEWE-ORION-1622-10x

## 2.5.1.1 DEWESoft settings

In Dewesoft there are three basically functions implemented:



## 2.5.2 Basic counter organisation

Figure 3 shows the principal of a counter block. Every counter channel consists basically of a main counter and a sub counter.

The main counter consists of 4 inputs. The input “Armed” is needed for starting and triggering the counter. The basic input of a counter is the source pin. The default usage of this input is event counting. In addition to the gated counting mode the “GATE” input is also the standard input for period measurement. The AUX input is for special functions like up/down counting or encoder measurement.

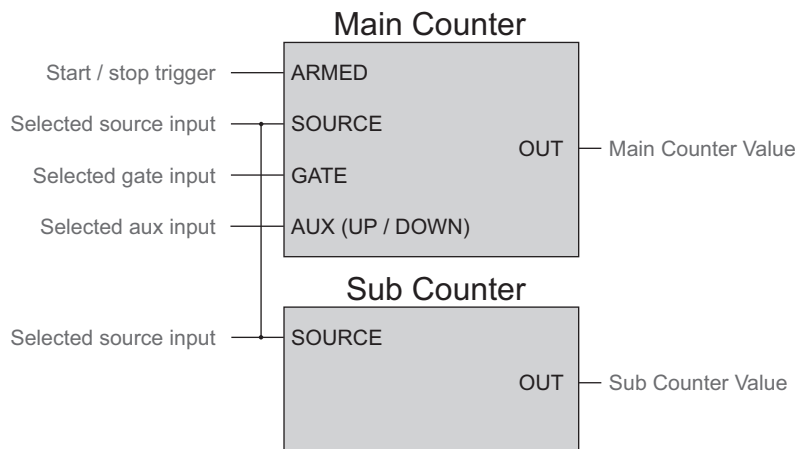

Figure 3: Counter functions

# DEWE-ORION-1622-10x

The sub counter is automatically switched on in the background if the measurement result needs principal two counters. For example measuring the duty cycle of an input signal needs the information of the period time and the pulse width for the calculation. Also for precise measurement the frequency of a signal synchronized to analog samples two counters are needed.

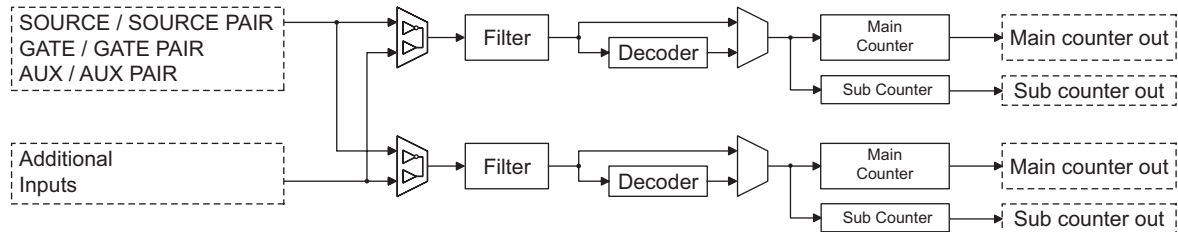

Figure 4: Basic counter organization

## 2.5.3 Counter and DI/O DEWE-ORION-1622-100/101

The counters and digital input and output at the DEWE-ORION-1622-100 can be configured in the most flexible way. DI0 to DI7 can be used as digital input and / or for the counter inputs. Please refer also to the input connector description above.

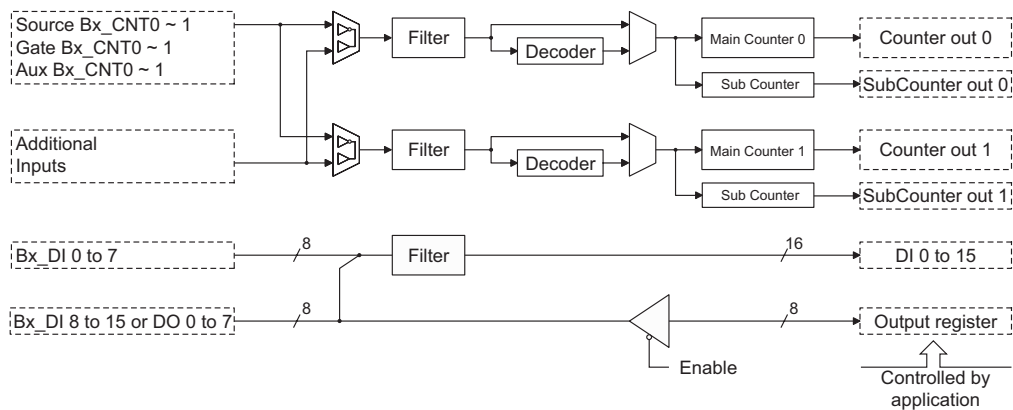

Figure 5: Counter and digital input organization

In addition to the basic counter input selections also several additional inputs can be used as counter source.

Source input	Gate input	AUX input
Source Bx_CNT(n)	Gate Bx_CNT(n)	Aux Bx_CNT(n)
Source from pair counter	Gate from pair counter	AUX form pair counter
Gate Bx_CNT(n)	Source Bx_CNT(n)	Source Bx_CNT(n)
Gate from pair counter	Source from pair counter	Source from pair counter
Aux Bx_CNT(n)	Aux Bx_CNT(n)	Gate Bx_CNT(n)
AUX form pair counter	AUX form pair counter	Gate from pair counter
ADC Clock	ADC Clock	ADC Clock
40 MHz		
Bx_DI6	Bx_DI6	Bx_DI6
Bx_DI7	Bx_DI7	Bx_DI7
EXT_CLK	EXT_CLK	EXT_CLK
EXT Trigger	EXT Trigger	EXT Trigger
EXT_CLK1	EXT_CLK1	EXT_CLK1
EXT_CLK2	EXT_CLK2	EXT_CLK2

The upper 8 bits of the digital input word also can be configured to output. Writing the outputs is an asynchronous action defined by the host application software. But even when if the output mode is activated the output level also can be measured to get the exact timing information when the output is really set.

# DEWE-ORION-1622-10x

## 2.5.4 Counter and DI/O DEWE-ORION-1622-102/103

The number of counters and digital inputs can be expanded with the counter expansion add-on board. All the baseboard functionality stays the same like in the standard configuration. Similar to the counter inputs of DEWE-ORION-1622-100/101, the input pins can also share the function for digital inputs or counter inputs. Please also refer to the pin-out description in chapter 2.3.1. The block diagram (figure 6) indicates that eight counter channels and theoretically 16 digital inputs can be transferred at once. If higher digital input count is used the counter no. 7 is switched off.

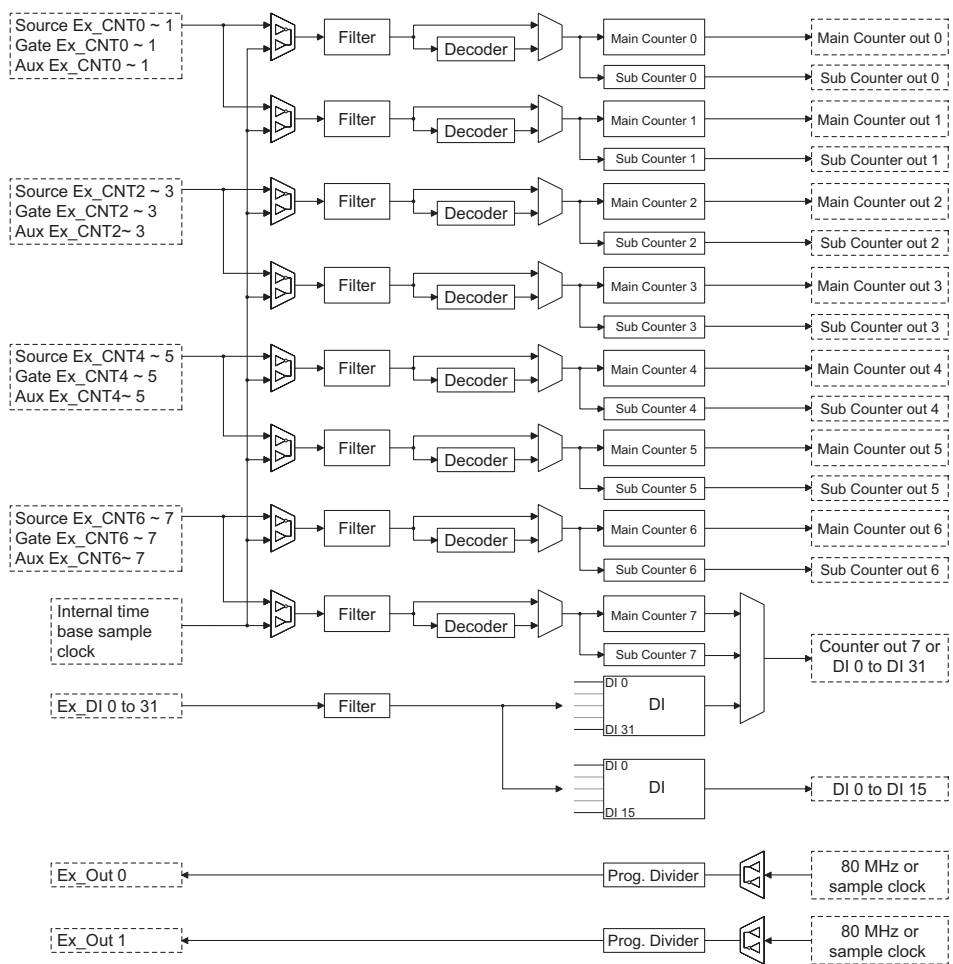

Figure 6: Counter and digital input organization

The counter input selection table below shows the input routing possibilities.

Source input	Gate input	AUX input
Source Ex_CNT(n)	Gate Ex_CNT(n)	Aux Ex_CNT(n)
Source from pair counter	Gate from pair counter	AUX form pair counter
Gate Ex_CNT(n)	Source Ex_CNT(n)	Source Ex_CNT(n)
Gate from pair counter	Source from pair counter	Source from pair counter
Aux Ex_CNT(n)	Aux Ex_CNT(n)	Gate Ex_CNT(n)
AUX form pair counter	AUX form pair counter	Gate from pair counter
ADC Clock	ADC Clock	ADC Clock
40 MHz testsignal		

There are two output channels available. Each channel can be connected to two input signals via multiplexer (80 Mhz or sample clock). After the input selection, the signal passes the programmable divider, where high time and low time of the signal can be varied. The output channels are activated if the ORION-EXP-CNT8-TTL is in data acquisition mode. Otherwise the output channels are inactive.

# DEWE-ORION-1622-10x

The output settings can be done inside the hardware setup of DEWESoft.

Device information									
ID	Name	Sample rate	AI chnls	AI bits	SN (Cal. date)	CNT chnls	DI chnls	OutClk: Ext1;Ext2;Ext;	
0	ORION-1622-102	102400	16	22	SN:2571292 (2008/01/24)	2	0	Video; CAN; Off	
0	Expansion CNT	102400	-	-	SN:15460003	8	0	Out0: Off;Out1: Off;	

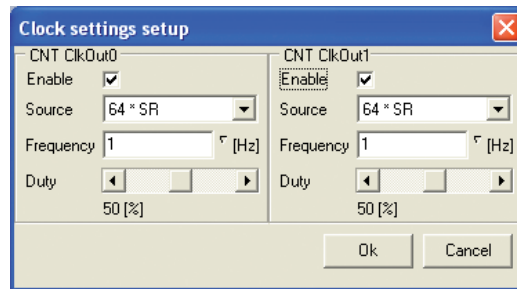

## 2.5.5 Counter and DI/O DEWE-ORION-1622-104/105

Similar to DEWE-ORION-1622-102/103 this board provides eight advanced counter channels and up to 32 digital inputs where the input pins can share this functionality.

The difference is just the electrical input circuit. The DEWE-ORION-1622-104/105 provides high voltage differential inputs protected up to 100 Vpeak with a common minus input (for example In- Ex\_CNT0) for each counter. Furthermore a programmable trigger and re-trigger level of each input, from 0 to 40 Volt and a software selectable AC/DC coupling with 1 Hz cut off frequency, is included.

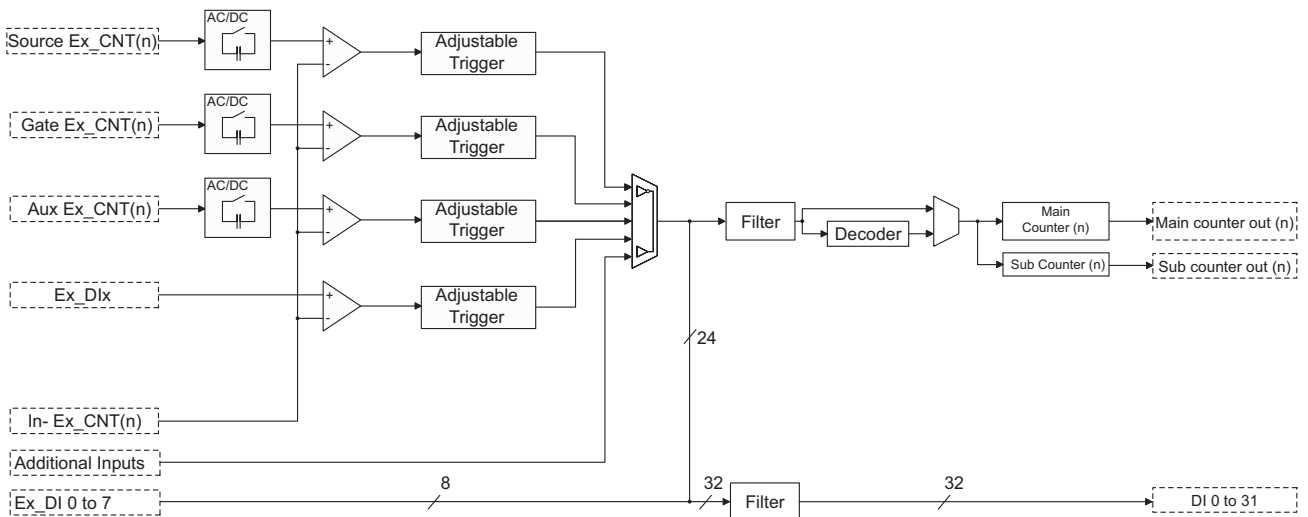

With the adjustable counter expansion ORION-EXP-CNT8-ADJ it is possible to set the trigger level and the Retrigger level between 0 and 40 V with a resolution of 40 mV. If the input signal exceeds the value of the trigger level the logical value will be "HIGH" and if the input signal falls below the Retrigger level the logical value is "LOW". As an additional feature the input can be also set to AC coupling for removing the DC component of the input signal.

The diagram on the next page illustrates the functionality of the settable trigger levels.

# DEWE-ORION-1622-10x

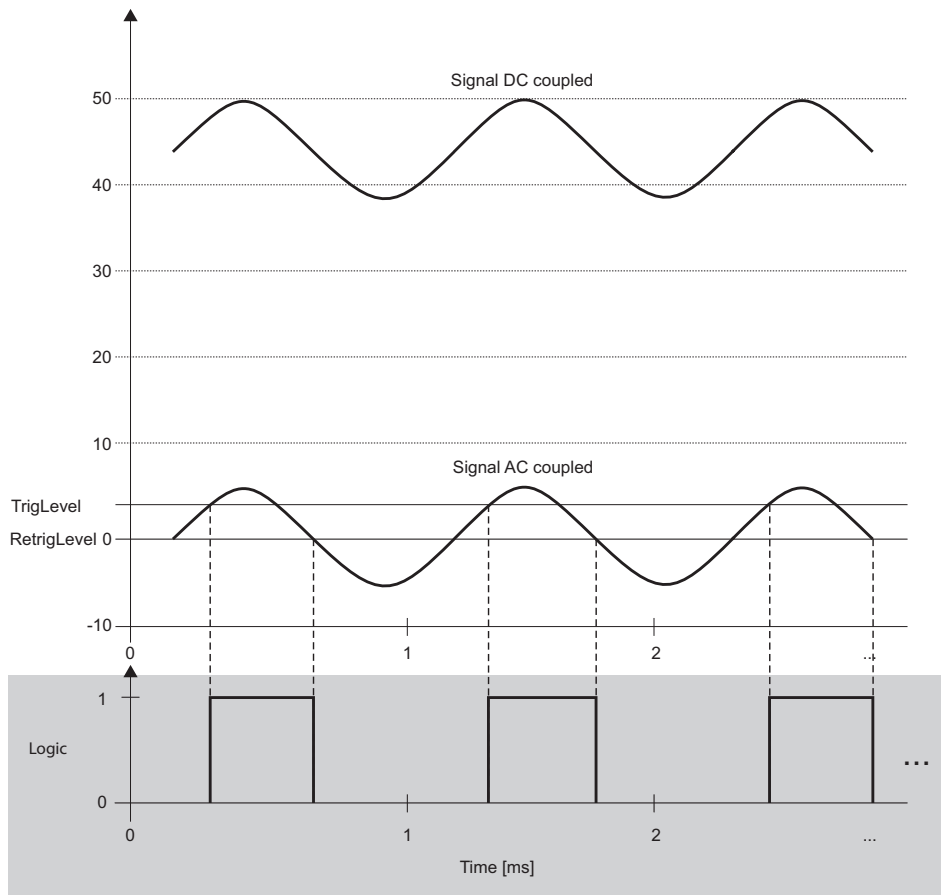

The levels can be set for each input independent like shown on the next page. Some common used levels are predefined (like TTL, inductive pick-up sensors...). Selecting “Custom” as the trigger type. All parameters are free definable.

Signal	Source	Trig type	Coupling	TrigLevel [V]	ReTrigLevel [V]
Signal A	Source_B0_CNT0	Custom	AC	4	0
Signal B	Aux_B0_CNT0	TTL/CMOS	DC	2	0,8
Signal Z	Gate_B0_CNT0	Inductive	AC	1	0,4

Channel	Source	Revs	Start	End	Revs
Unused	B0_CNT0	0	1	0	-5
					0 revs 5

If the sensor signal is not known, an automatic algorithm for finding the trigger levels is implemented. A sensor like the shown encoder has usually for all outputs the same signal level. Enabling “trigger settings same for all lines” sets automatically the same level to all used inputs.

# DEWE-ORION-1622-10x



## 2.6 Clock and trigger I/O

The DEWE-ORION-1622-10x allows external triggering for start of the acquisition using the pin EXT\_Trigger. The default detection for the trigger signal is the rising edge but can be configured to falling or both edge (change of input signal) detection. Changing the direction to output, the start of acquisition can be indicated.

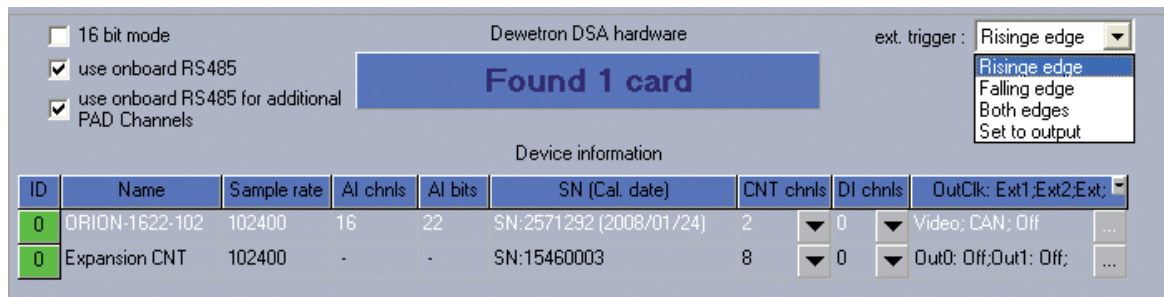

EXT\_CLKx are used as standard for hardware synchronization to DEWE-CAM, CAN or 3<sup>rd</sup> party hardware. Each output can set individually. The predefined settings are:

- Video:** The output frequency is automatically set to the frame rate of the selected video device. If no camera is selected, the output is disabled
- CAN:** The signal is automatically set for hardware synchronisation of NI-CAN device. If no CAN device is selected, the output is disabled
- FAN:** This allows to switch off the system FAN during storing the data. This specially feature is important for sound measurement and needs to be ordered separately.
- Fixed:** Outputs the entered frequency synchronized to the sample clock oscillator based on a 12.8 MHz divider. The output starts and stops with the acquisition. The selection of "continuous out" allows to output the clock rate also after the acquisition is stopped. Continuous out selection at signal EXT\_CLK starts also the acquisition always synchronised with the rising edge of the output.

# DEWE-ORION-1622-10x

*Note: This output frequency is only synchronized to the sample frequency at the master board*

ADC\_CLK: Outputs the actual sample frequency. The selection “continuous out” is only allowed at the master board (board 0).

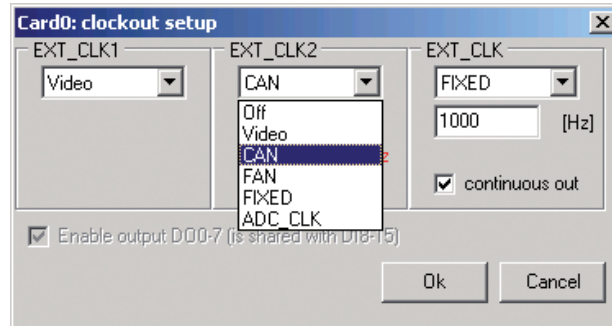

The default settings for the master board are:

EXT\_CLK1: Video  
 EXT\_CLK2: CAN  
 EXT\_CLK: Off

The output of all slave board is switched off.

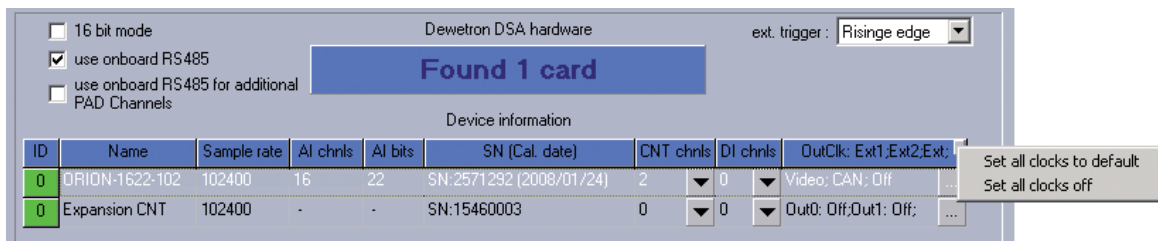

The diagram below gives an idea of the internal structure of EXT\_CLKx and EXT\_Trigger circuit:

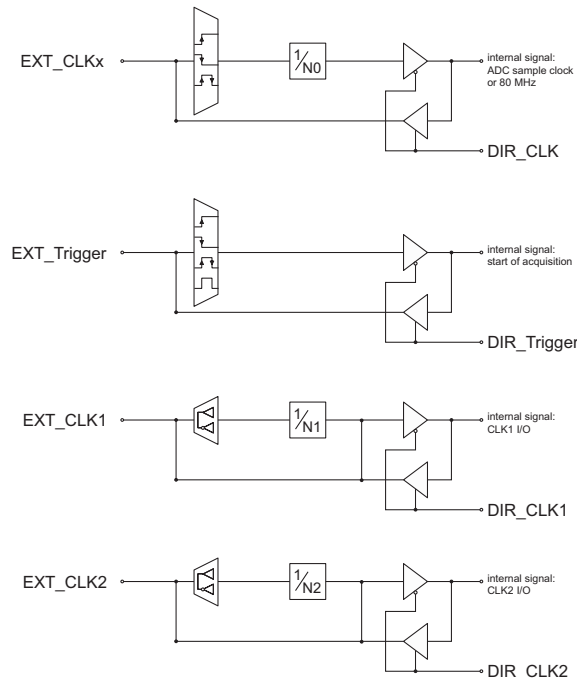

Figure 7: Clock and trigger I/O configuration

The direction (input or output) of each pin can be switched separately.

## 2.7 CAN interface

As an option the DEWE-ORION-1622-10x also can be suited with two high speed CAN interfaces. Both ports are compatible with CAN 2.0B specification. The CAN transceiver (TI SN65HVD235) has a bus-pin fault protection of up to  $\pm 36$  V.

The main application for these CAN-ports is acquiring CAN data together with analog data. Although the CAN data is asynchronous to the analog data, the DEWE-ORION-1622-10x series guarantees perfect synchronization. Each incoming CAN message is directly time stamped to the analog sample count number before the data is transferred to the application software.

If just CAN acquisition of CAN messages is required the “Listen Only” mode can be used. In this mode the DEWE-ORION-1622-10x board generates no output data even if the CAN-baud-rate is wrong selected. But this mode is not working using just a direct connection to a sensor. In a point-to-point connection the “Listen Only” mode has to be deactivated at the CAN-Interface. The setup in DEWESoft is shown in the screenshot on the next page.

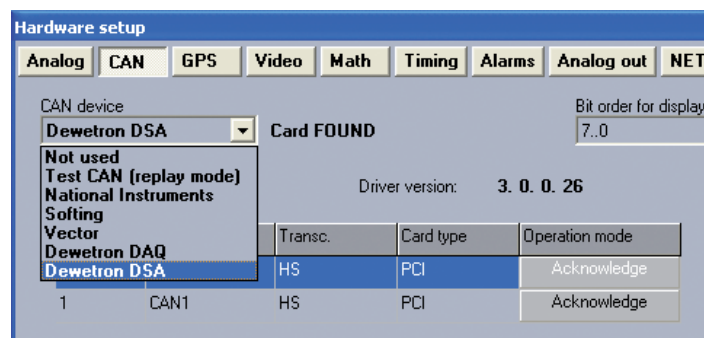

CAN setup in DEWESoft

## 2.8 RS-485 interface

The DEWE-ORION-1622-10x is suited with an RS-485 interfaced as standard. The baud-rate is fixed to 9600, 8 Data, 1 Stop bit and no parity. This interface is used for configuration of the DAQ and MDAQ signal conditioning modules. Also the acquiring of PAD and EPAD from DEWETRON is possible with this RS-485 port. The interface of the main board and the expansion boards (DEWE-ORION-1622-102, DEWE-ORION-1622-104, DEWE-ORION-3222-100 with counter expansion) is controlled separately.

# DEWE-ORION-1622-10x

## 2.9 Synchronizing multiple devices

### 2.9.1 Internal synchronisation

For multiple device operation the DEWE-ORION-1622-10x is equipped with an additional synchronization connector. A standard 10-pin connector with 1.27 mm flat ribbon cable is available for easy connection between the boards. To reduce electromagnetic influences because of the very high frequency at this synchronization bus, IEEE 1394 compatible LVDS (low voltage difference signals) are used.

The LVDS interface is current-based. Therefore the last board has to be terminated. This can be done with a switch, positioned directly below the sync connector.

*If you use only one DEWE-ORION-1622-10x in your system, the board has to be terminated.*

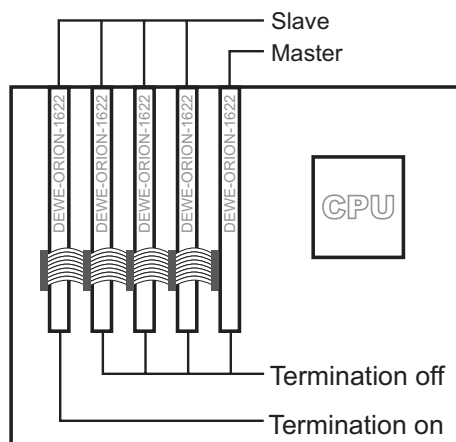
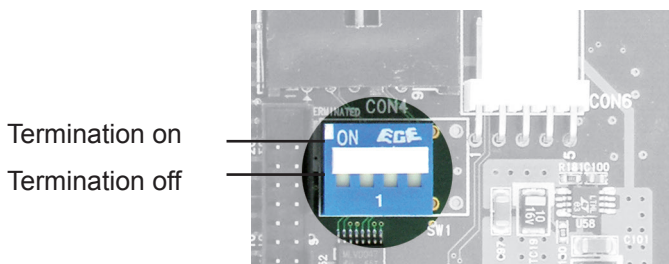

## 2.9.2 Synchronising multiple systems

If multiple systems or PCI expansion systems are used, a synch-bus repeater (ORION-DSA-SYNC) has to be used (ordering option ORION-1624-SYNC). This repeater decouples the internal synch-bus with the external synchronization input and output connector. This gives the possibility to expand the distance between two systems by up to 35 meters using standard CAT5 Ethernet cables.

*Please contact DEWETRON if longer synchronization distance is required! Please also refer to DEWE-GPS-CLOCK or DEWE-IRIG-CLOCK for additional synchronisation methods.*

The ORION-DSA-SYNC also includes the security circuit if two master systems have to be connected together over the synch bus connection. As soon as the system is configured to a master system the external synch is ignored by disabling the SYNC-IN amplifier. The LED MI (master internal) indicates if the system is configured to a master system. ME (master external) is on, if at the SYNC-IN connector a valid SYNC signal is connected.

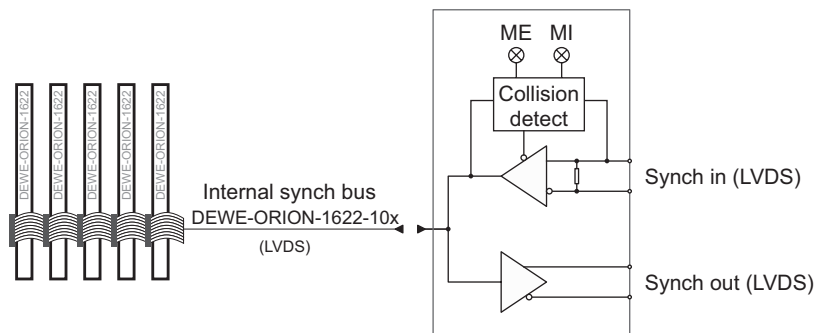
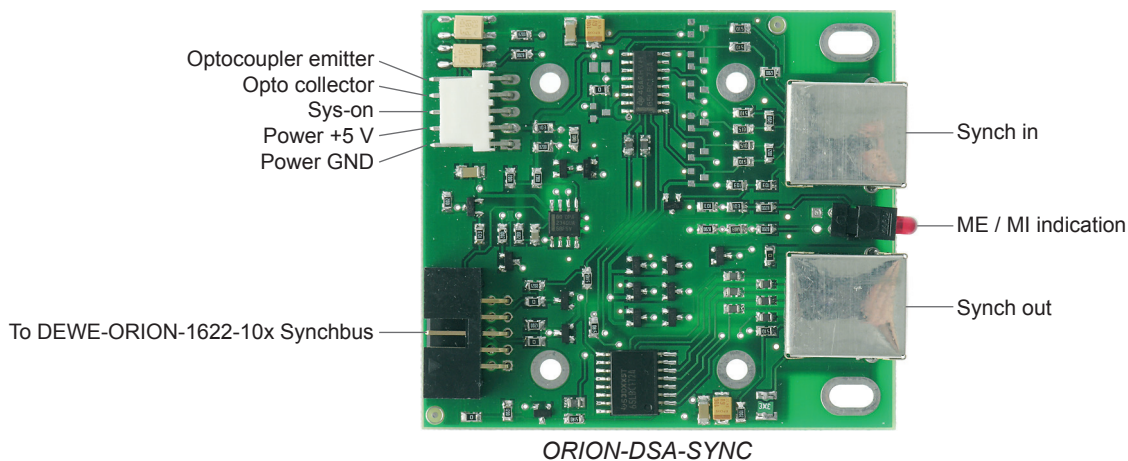

Figure 9: Synchronizing multiple systems

The delay of the synchronisation bus within on system is negligible low (<1 nsec). But also the delay of the ORION-SYNC is lower than 14 nsec (one input and one output amplifier) and will have no significant effect on the inter channel phase mismatch of the complete data acquisition system. A delay of 14 nsec is nearly the same delay produced by 3.5 m cable (current time inside the cable)



In addition to the synchronization function the ORION-DSA-SYNC allows also to remote power the slave-system. As soon as a master system is present an opto coupler output (PC817) is activated to switch on the power supply. The remote power on also can be controlled with an external control voltage (+5 V@Sys-On).

# DEWE-ORION-1622-10x

## 2.9.3 Defining the board order

In multiple boards application the location of each single board has to be known. This is required to get the correct channel mapping at the application software. The PCI bus structure does not allow a guaranteed board allocation. However, the whole PCI-bus in a PC system is organized in bus and device numbers. The combination of both numbers is unique inside a PCI-bus based system.

By default the DEWE-ORION-1622-10x device driver orders the board beginning with the lowest PCI-bus No. and lowest device number to increasing device No. and PCI-bus No ...

If the system configuration needs to be changed, please modify the settings shown in the next screens. Get this window at Start > Settings > Control Panel > System > Hardware > Device Manager

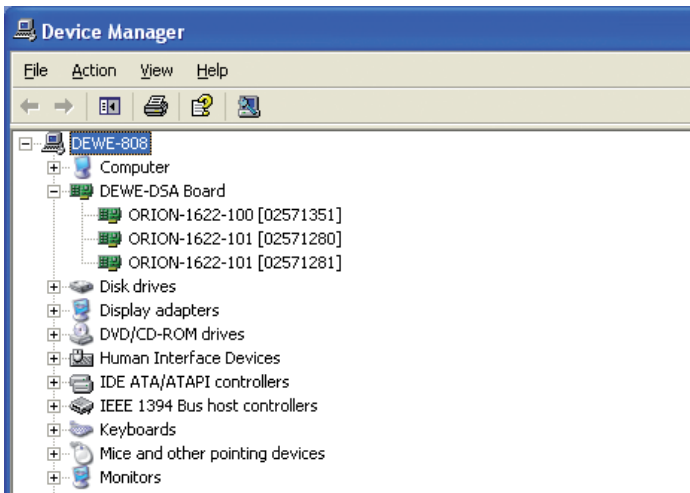

Device manager

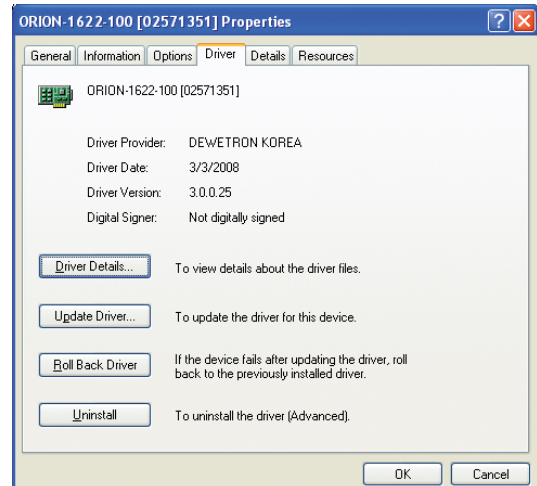

Click on "driver details" to get the next screen

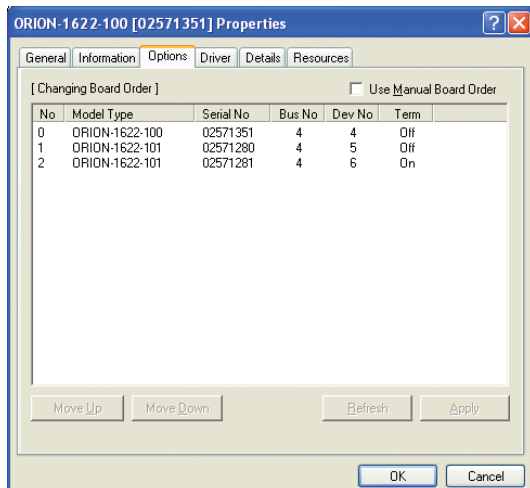

Info screen

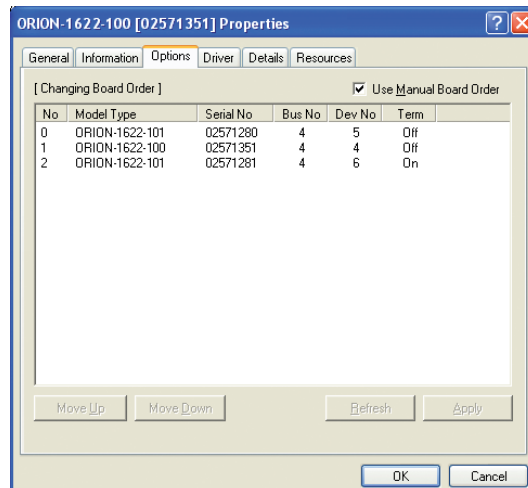

ORION cards in manual sorted order

The order can be changed by clicking on the name of the board and moving it with the move up/down buttons. Please note that the settings are taken only after clicking the button <Apply>. A click on the <Refresh> button shows the actual settings.

## Notes

# DEWE-ORION-1622-10x

## 3 Theory of operation

### 3.1 Analog Input

#### 3.1.1 Functional overview

The analog function block diagram below shows the signal processing of the DEWE-ORION-1622-100.

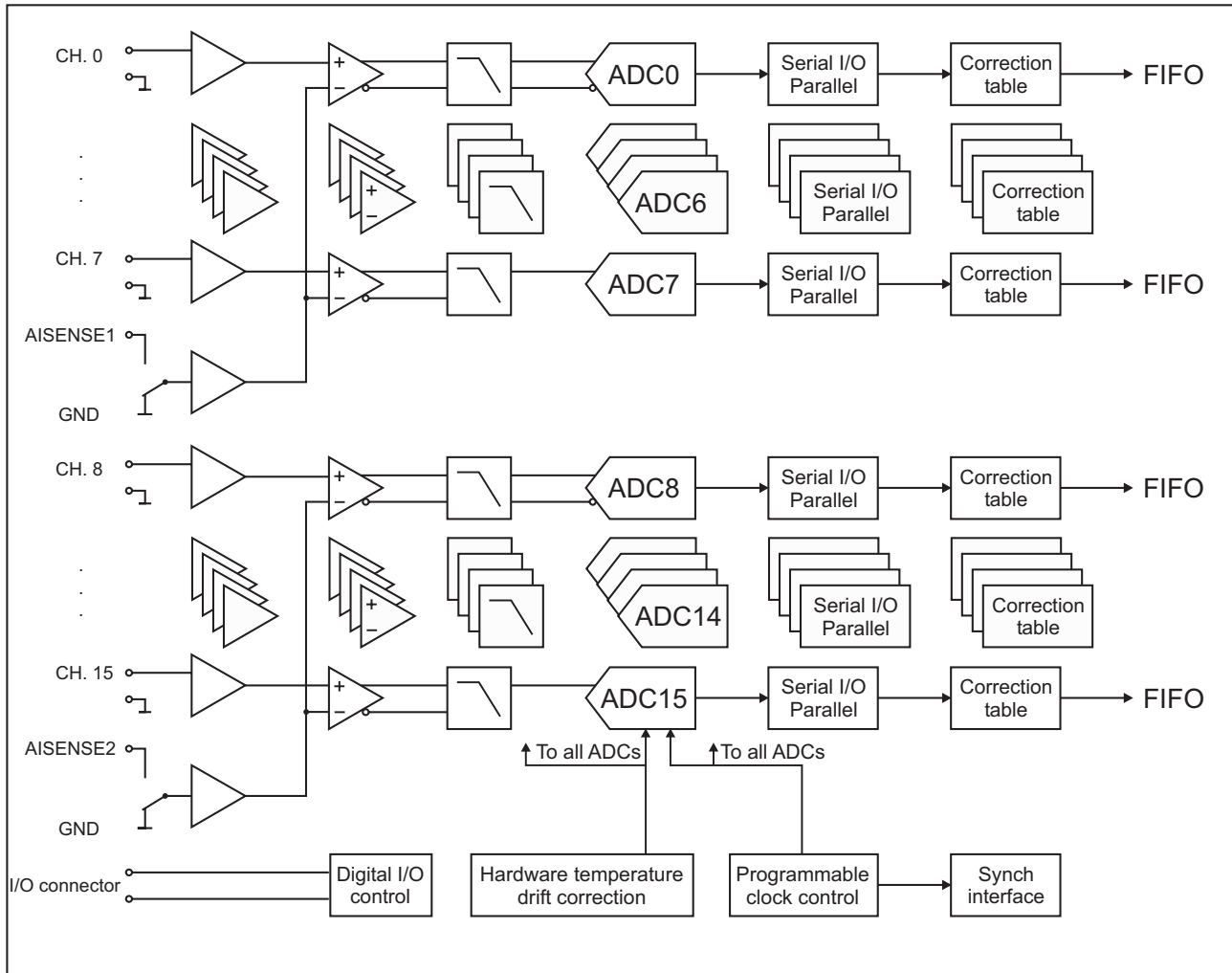

#### 3.1.2 Analog input configuration

Block diagram for one of the 16 identical DEWE-ORION-1622-10x analog inputs.

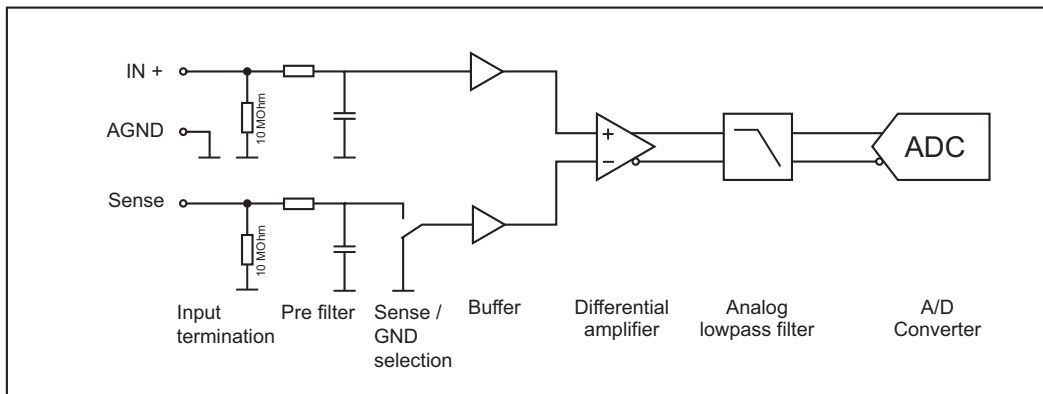

The high input impedance (10 MOhm ground referenced) has no distortion influence to the measured signals. 22-bit resolution and software-programmable rates up to 102.4 kS/s allow high performance data acquisition.

### 3.1.3 Analog to digital conversion

The DEWE-ORION-1622-10x uses 16 delta-sigma A/D converters. If you sample with a data rate of 102.4 kS/s, the ADC actually samples the input signal with 13.1072 MS/s (multiply the data rate with 128) and produces 1-bit samples which are applied to the digital filter. The filter expands the data to 22-bits and rejects signal parts greater than 51.2 kHz (Nyquist frequency). It also re-samples the data to the more conventional rate of 102.4 kS/s.

A 1-bit quantizer introduces many quantization errors to the signal. The 1-bit, 13.1072 MS/s from the ADC carry all information to produce 22-bit samples at 102.4 kS/s. The delta-sigma ADC converts from high speed to high resolution by adding much random noise to the signal. In this way the resulting quantization noise is restricted to frequencies above 100 kHz. This noise is not correlated with the useful signal and is rejected by the digital filter.

### 3.1.4 Anti-alias filter

ADCs can only represent signals of a limited bandwidth. The maximum frequency you can represent is the half of the sampling rate. This maximum frequency is also called Nyquist frequency. The bandwidth between 0 Hz and the Nyquist frequency is called Nyquist bandwidth. Signals exceeding this frequency range can not be converted correctly by the sampler.

For example, the sample rate is 1000 S/s, the Nyquist frequency is 500 Hz. If the input signal is a 375 Hz sine wave, the resulting samples represent a 375 Hz sine wave. If a 625 Hz sine wave is sampled, the resulting samples represent a 375 Hz sine wave too. This happens because signals exceeds the Nyquist frequency (500 Hz). The represented frequency of the sine wave is the absolute value of the difference between the input frequency and the closest integer multiple of the sampling rate (in this case 1000 Hz).

Some examples:

Input sine wave 2280 Hz, sampling frequency 1000 Hz:  $2280 - 2 * 1000 = 280$  Hz

Input sine wave 3890 Hz, sampling frequency 1000 Hz:  $4 * 1000 - 3890 = 110$  Hz

When the sampler modulates frequencies out of the Nyquist bandwidth back to the 0 to 500 Hz baseband it is called aliasing. Signals which are not pure sine wave can have many components (harmonics) above the Nyquist frequency. These harmonics are erroneously aliased back to the baseband, added to parts of the accurately sampled signal and produces a distorted data set. To block frequencies out of the Nyquist bandwidth, a lowpass filter is applied to the signal before it reaches the sampler.

Each input channel has its two pole anti-alias lowpass filter with a cutoff frequency of about 250 kHz. The very high cutoff frequency allows an extremely flat frequency response in the bandwidth of interest and a small phase error. The analog filter precedes the analog sampler. The analog sampler operates at 256 times the selected sample rate for rates below 51.2 kS/s, 128 times for rates between 51.2 kS/s and 102.4 kS/s. For rates over 102.4 kS/s the oversampling is 64 times. That means, the ADC operates at 13.1072 MS/s if you select a sample rate of 102.4 kS/s ( $128 * 102.4$  kS/s).

The 1-bit oversampled data is passed to a digital anti-aliasing filter. This filter has no phase error and an extremely flat frequency response. It also has an extremely sharp roll-off near the cutoff frequency (0.38 to 0.494 times the sample rate) and the rejection above 0.5465 times the sample rate is greater than 92 dB. The output stage of the digital filter resamples higher frequencies to 22-bit samples.

The digital filter passes only signal components within the Nyquist bandwidth or within the Nyquist bandwidth at 128 or 256 times (depending on sampling rate) the sample rate and multiples of it. The analog filter rejects most noise near these multiples. The following diagrams show the frequency response of the input circuitry.

# DEWE-ORION-1622-10x

Sample rate 1 kS/s to 51.2 kS/s

Input frequency response

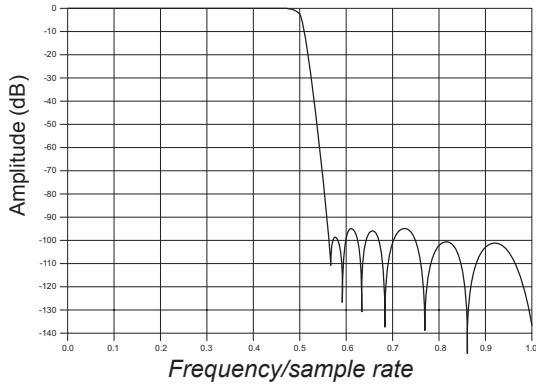

Input frequency response near the cutoff

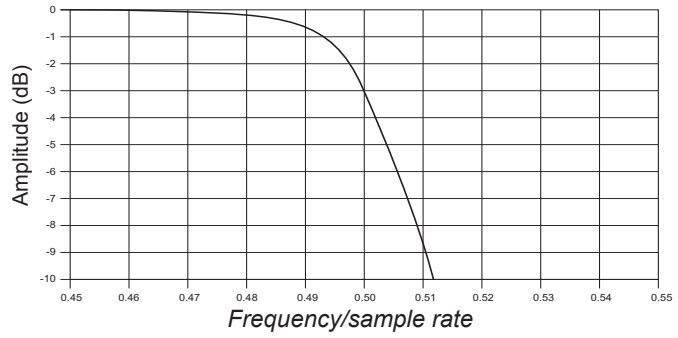

Sample rate 51.2 kS/s to 102.4 kS/s

Input frequency response

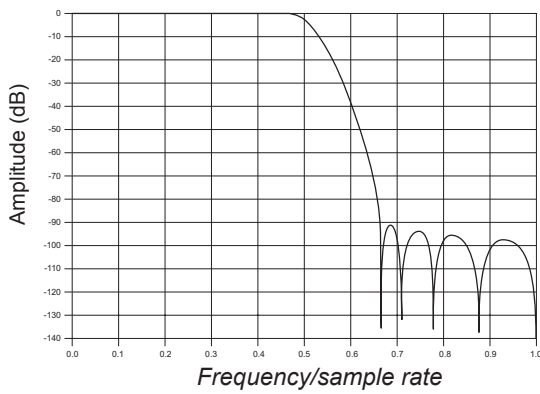

Input frequency response near the cutoff

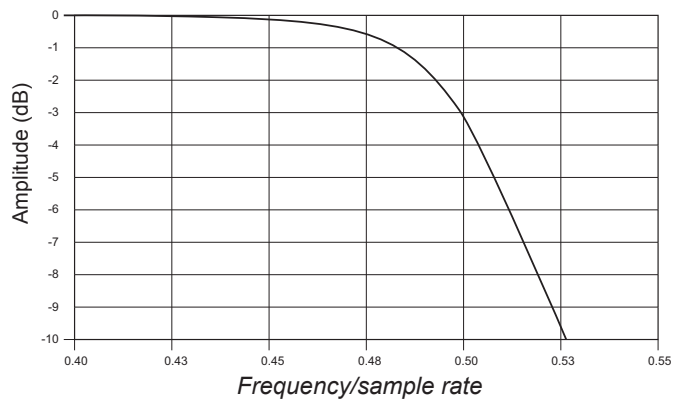

The ADC samples at 128 or 256 times the data rate (depending on the adjusted sample rate). Frequency components above one half of the oversampling rate (> 64 or 128) can alias. Most of this frequency range is rejected by the digital filter. The filter can not reject components that lie close ( $\pm$ Nyquist bandwidth) to integer multiples of the oversampling rate because it can not differentiate these components from components between 0 Hz and the Nyquist frequency. That means, if the sample rate is 10 kS/s and a signal component is between 2.555 and 2.565 MHz ( $256 \times 10 \text{ kHz} \pm \text{Nyquist bandwidth}$ ), this signal will be aliased into the passband region and is not rejected by the digital filter. The analog filter removes these components before they get to the digital filter and the sampler.

The frequency response of the analog filter is fixed. The filter is optimized to produce high-frequency alias rejection and to have a flat in-band frequency response. It is a second order filter with a slow roll-off that rejects aliases at lower sample rates not so good. But the filter has very good alias rejection at higher sample rates.

If aliasing is caused by a clipped or overranged waveform, (exceeding the voltage range of the ADC) it can not be rejected with any filter. The ADC assumes the closest value to the actual value of the signal in its digital range when the signal is clipping. The result of clipping is also a sudden change in the signal slope and results in corrupt digital data with high-frequency energy. This energy is spread over the complete frequency spectrum and is aliased back into the baseband. Do not allow the signal to exceed the input range to avoid this.

### 3.1.5 Sample clock selection

Due to the nature of delta sigma converters they have to overclock the ADC to reach the high accuracy specification. The overclocking rate varies with the sample rate:

256 for  $1 \text{ kS/s} \leq 51.2 \text{ kS/s}$

128 for  $1 \text{ kS/s} < f_s \leq 102.4 \text{ kS/s}$

That means at 50 kS/s the delta sigma converter is clocked with 12.8 Mhz ( $50 \text{ kHz} * 256$ ).

To set nearly each frequency a low jitter programmable PLL (phase locked loop) circuit is used for generating the clocking frequency. PLL gives the best solution for variable frequency setting with small steps between the frequency. But still not every frequency is possible to set. The formula below gives you an idea how the frequency can be set to get different sample rates:

$$\frac{12.8 \text{ MHz}}{Q} \cdot P \cdot \frac{1}{N} \cdot \frac{1}{OC}$$

where Q is limited from 2 to 51; P is limited from 8 to 1600 and N is limited from 1 to 127. OC for  $f_s$  1kS/s  $\leq 51.2 \text{ kS/s}$  equals 1024 and for higher sample rates it is fixed to 256. Also the product of  $12.8 \text{ MHz}/Q * P$  has to be in the range of 100 to 400 MHz for stable operation. The factors Q, P and N are integer values and automatically set the best performance values. The table below give a rough idea about the sample rate resolution at different sample rates.

Sample rate	Resolution [ppm]	Resolution [Hz]
1kS/sec	40	0,04 Hz
10kS/sec	70	0,7 Hz
50kS/sec	400	20 Hz
100kS/sec	400	40 Hz

The exact value of the sample is read back (and displayed in DEWESoft) for knowing the exact sample rate.

The factors Q, P and N are integer values and automatically set the best performance values. The exact value of the sample is read back (and displayed in DEWESoft) for knowing the exact sample rate.

*All channels have to be acquired with the same sample rate. It is not possible to set different sample rates to some channels.*

# DEWE-ORION-1622-10x

## 3.1.6 Output data format

Due to the nature of the PCI Bus, each channel is transferred as a 32-bit value, although the converter output is only a 22-bit value. Multiple channel applications with high sample rates may limit the maximum sample rate. A 128 channel system with 100 kS/s will give a total output data stream of 51.2 MByte/sec.

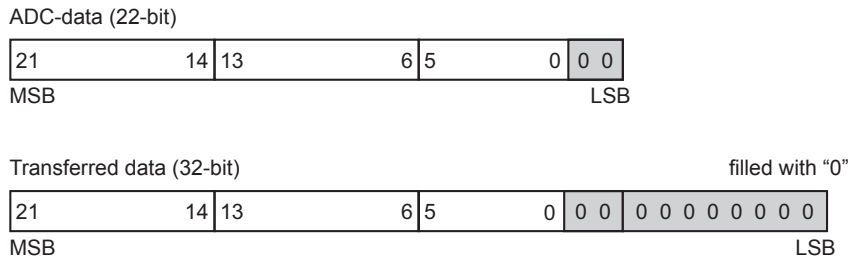

To reduce this high amount of data by half, a 16-bit mode is implemented. This 16-bit mode will only transfer 16 bits per ADC. Due to the selection of most significant 16 bits of the 22-bit ADC value, it is also possible to define the interesting array of bits which should be transferred. That means you have a kind of programmable range, using this packed mode.

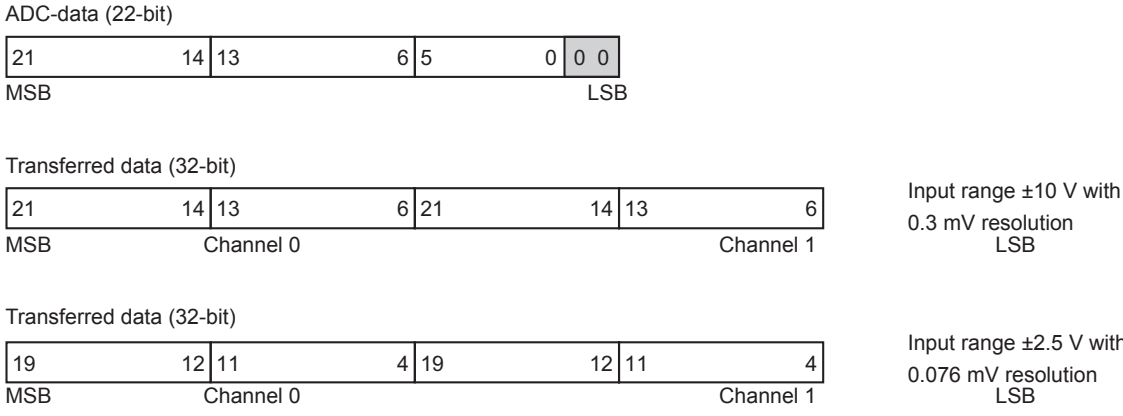

## 3.1.7 Calibration

Your DEWE-ORION-1622-10x is shipped with a calibration certificate. Typically a recalibration is required every year. The calibration constants are stored in the on-board EEPROM. The calibration can only be done with an optional available calibration kit. You are also able to send the DEWE-ORION-1622-10x back to DEWETRON for recalibration.

## 3.2 Counter input

### 3.2.1 Counter applications

As mentioned above each counter block is equipped with three inputs. With this three inputs the following applications can be done:

- Event Counting
- Gated Event Counting
- Up/Down Counter
- Frequency Measurement
- Period Time Measurement
- Pulse Width Measurement
- Two Pulse Edge Separation
- Quadrature Encoder (X1, X2, X4, A-Up/B-Down)

#### 3.2.1.1 Event Counting

In Event Counting the counter counts the number of pulses that occur on counter source. At every sample clock the counter value is read without disturbing the counting process.

Figure 12 shows an example of event counting where the counter counts eight events on *Counter Source*. *Synchronized Value* is the value read by the DEWE-ORION-1622-10x board at *Sample Clock* (encircled numbers in the figure, e.g. ①, ②).

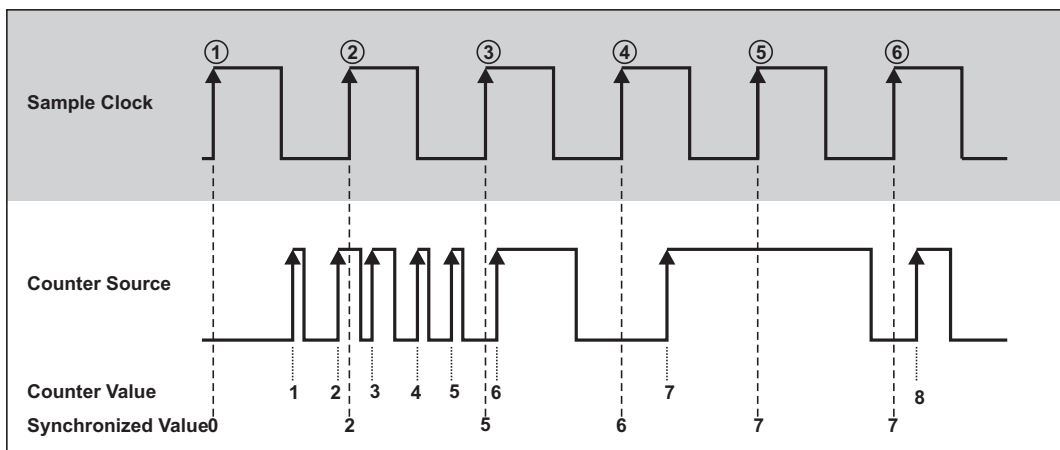
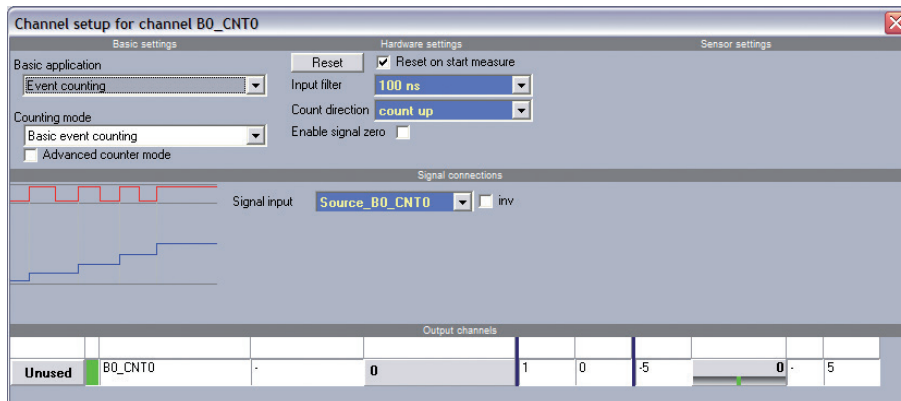

Figure 12: Event Counting

*If counting at falling edges is necessary, the input signal has to be inverted. This can be done directly on the ORION-EXP-CNT6 by selecting inverted input.*

# DEWE-ORION-1622-10x



### 3.2.1.2 Gated Event Counting

Gated Event Counting is similar to Event Counting except that the counting process is gated. When *Counter Gate* is active, the counter counts pulses which occur on counter source. When *Counter Gate* is inactive the counter retains the current count value. At every *Sample Clock* the value is read.

Figure 13 shows an example of Gated Event Counting where the counter counts three events on *Counter Source*. At ① and ② the counter value is zero, because the gate signal is inactive. At sample clock ③, ④ and ⑤ the actual counter value is read out. At ⑥ the same value as at ⑤ is typed out.

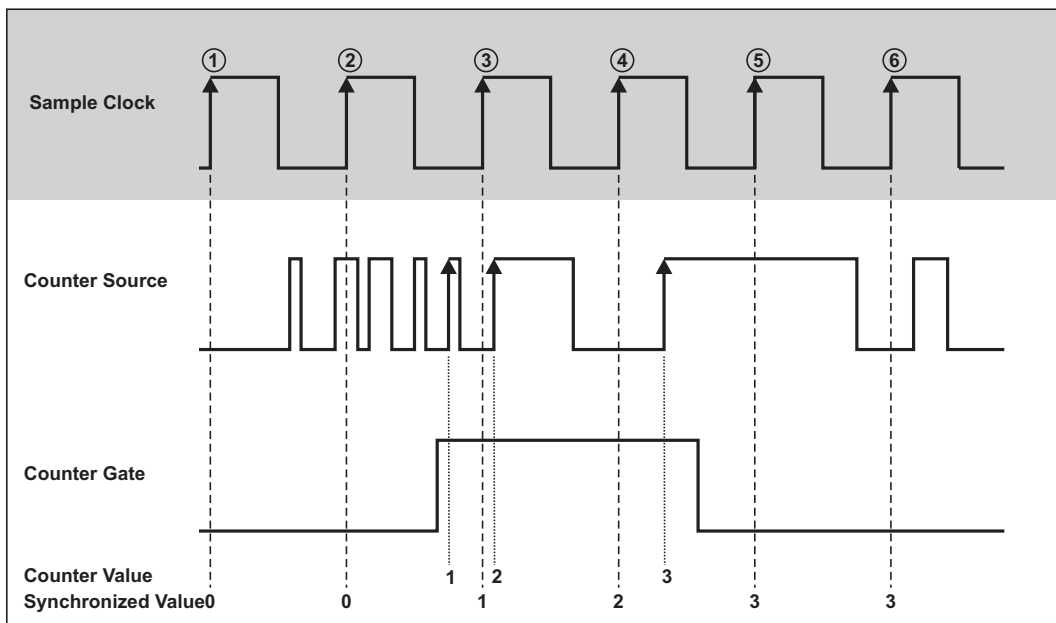
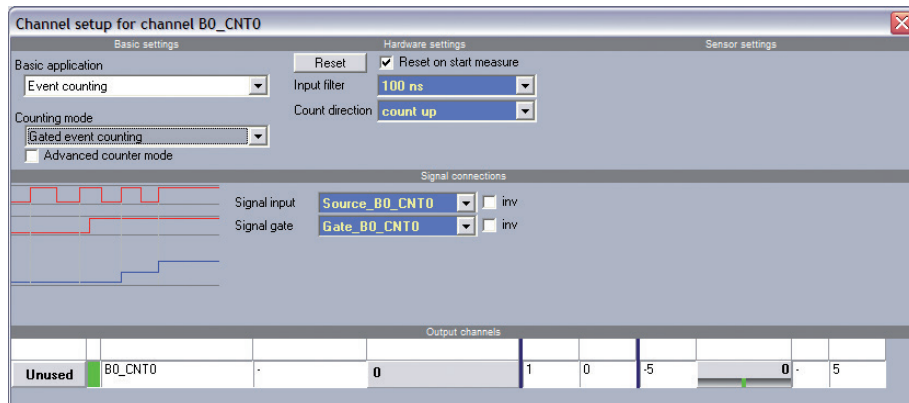

Figure 13: Gated Event Counting

*It is also possible, as in Event Counting, to invert the input signals.*



### 3.2.1.3 Up/Down Counter

The Up/Down Counter counts the rising edges on *Counter Source*. The direction of the counting depends on the signal state on *Counter Aux*. If *Counter Aux* is active (high level), the counter is increasing the counter value; if *Counter Aux* is inactive (low level), the counter is decreasing the counter value.

Figure 14 shows Up/Down counting.

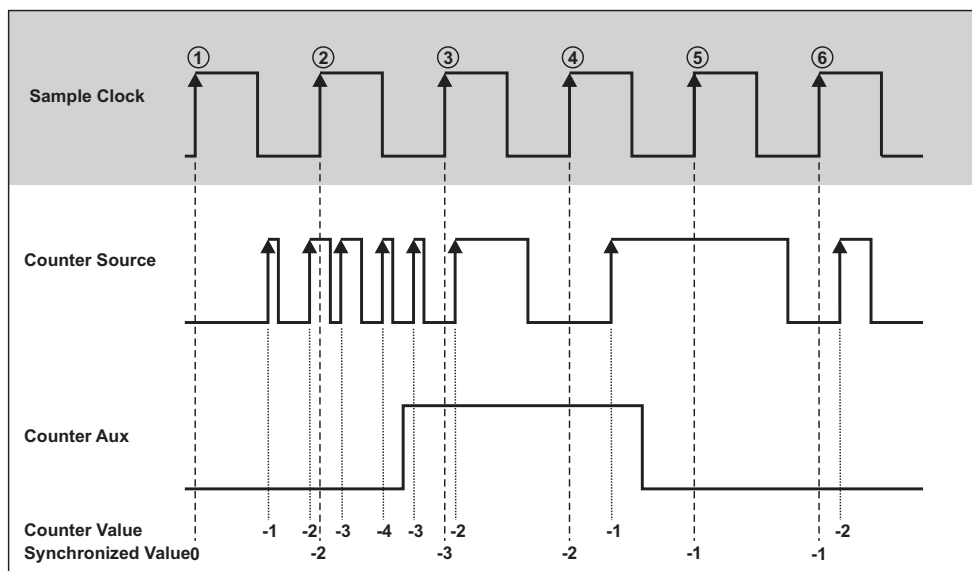
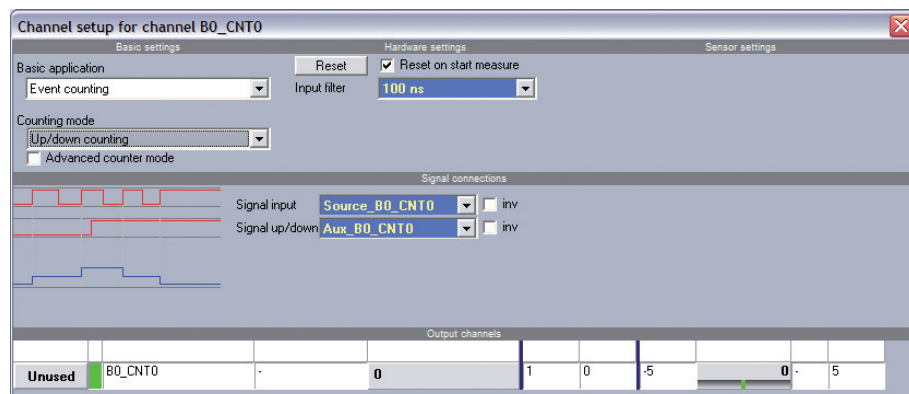

Figure 14: Up/Down Counter



# DEWE-ORION-1622-10x

## 3.2.1.4 Period Time Measurement

In Period Time Measurement the counter uses the internal time base to measure the period time of the signal present on *Counter Source*. The counter counts the rising edges of the internal time base which occurs between two rising edges on *Counter Source*. At the completion of the period interval the counter value is stored in a register and the counter starts counting from zero. At every *Sample Clock* (①, ②, ..., ⑥) the register value is read out.

Figure 15 shows a Period Time Measurement.

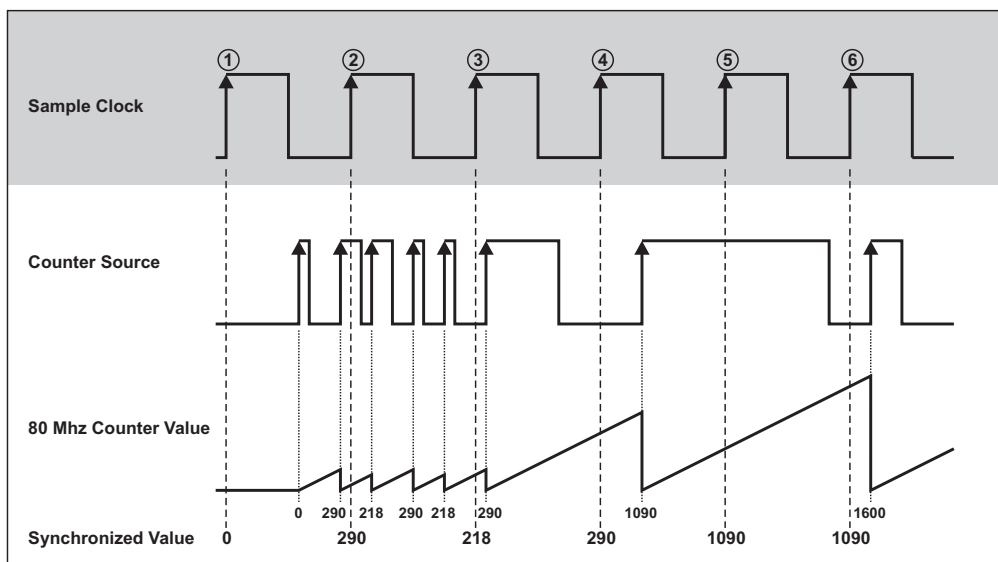
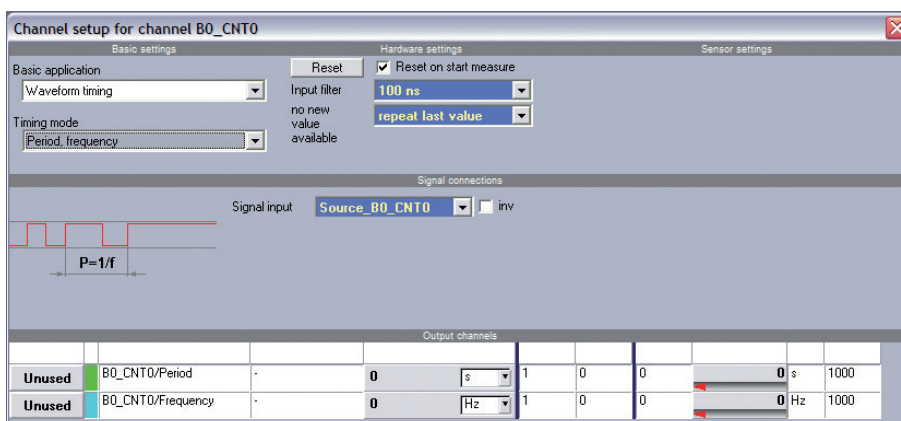

Figure 15: Period Time Measurement



## 3.2.1.5 Pulse Width Measurement

In Pulse Width Measurement the counter uses the internal time base to measure the pulse width of the signal present on *Counter Source*. The counter counts the rising edges of the internal time base after a rising edge occurs on counter source. At the falling edge on *Counter Source* the counter value is stored in a register and the counter is set to zero. With the next rising edge on *Counter Source* the counter starts counting again. At every *Sample Clock* (①, ②, ..., ⑥) the register value is read out.

Figure 16 shows a pulse width measurement.

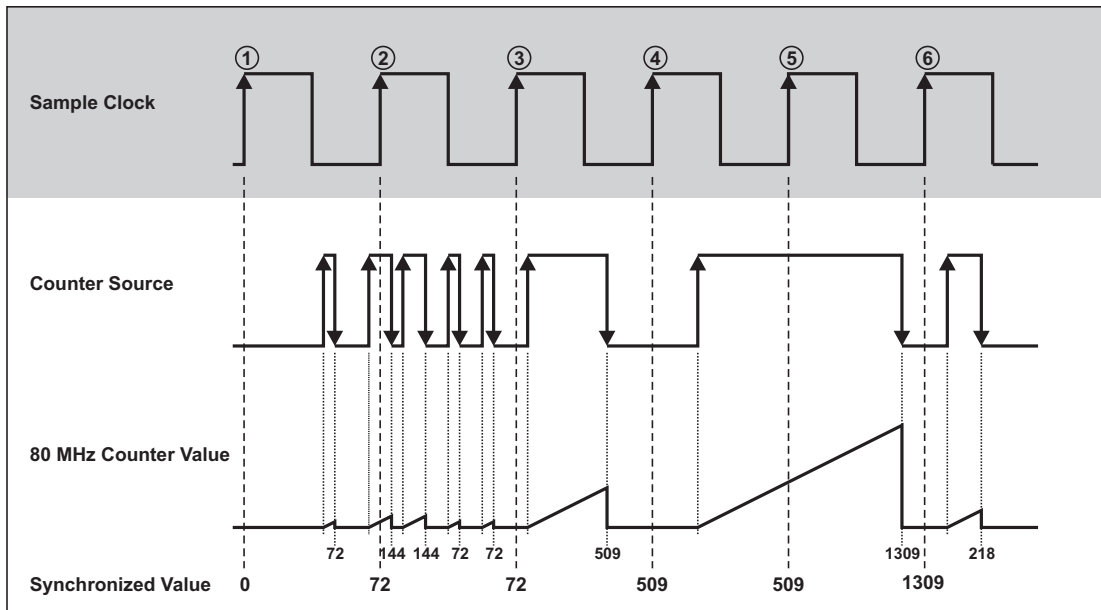
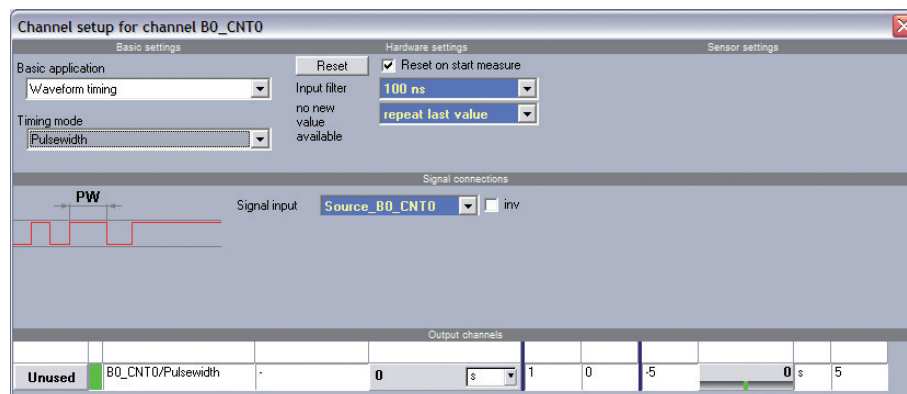

Figure 16: Pulse Width Measurement

For measuring the low time of the signal, the input signal has to be inverted on the ORION-EXP-CNT8.



### 3.2.1.6 Two Pulse Edge Separation Measurement

The two pulse edge separation measurement is similar to the pulse width measurement, except that there are two input signals: *Counter Start* and *Counter Stop*. After a rising edge has occurred on *Counter Start* the counter counts rising edges of the internal time base. Additional edges on signal start are ignored. After a rising edge has occurred on *Counter Stop* the counter stops counting and the value is stored in a register. At the next rising edge on *Counter Start* the counter starts counting from zero again. At every *Sample Clock* (①, ②, ..., ⑥) the register value is read out.

# DEWE-ORION-1622-10x

Figure 17 shows an example of Two Pulse Edge Separation Measurement.

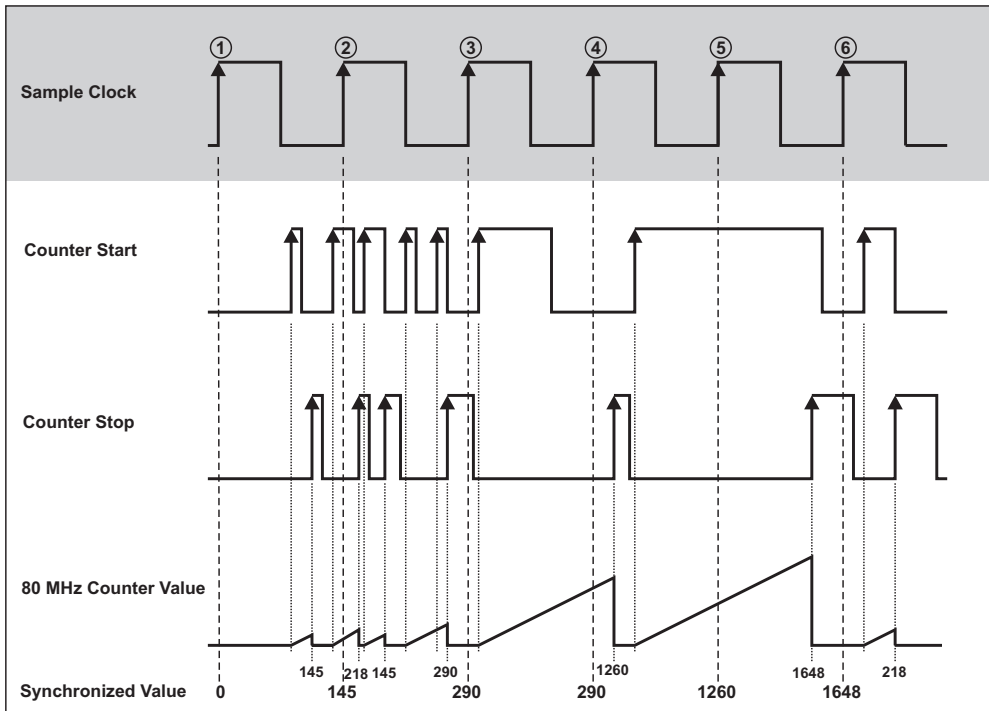
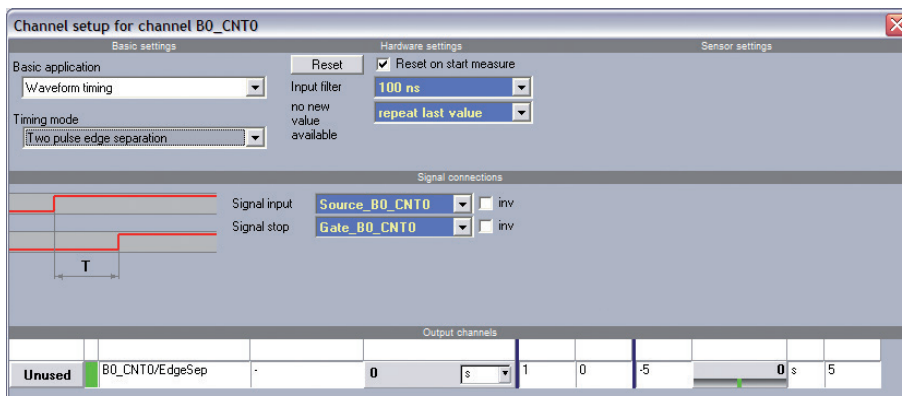

Figure 17: Two Pulse Edge Separation Measurement

*If the input signals are inverted the counter takes the falling edges for counting.*



### 3.2.1.7 Motion Encoder

Motion encoders have usually three channels: channel A, B and Z. Channel A and channel B are providing the square signals for the counter, and have a phase shift of 90°. With this phase shift the decoder is able to recognize the rotation direction of the motion encoder. The third channel types out one pulse at a certain position at each revolution. This pulse is used to set the counter to zero. The amount of counts per cycle at a given motion encoder depends on the type of decoding: X1, X2, X4. All three types are provided by the ORION-EXP-CNT8-TTL/ADJ. Some motion encoders have two outputs, which are working in a different way. Either channel A or channel B providing the square signal, depending on the direction of the rotation. Also this type is supplied by the ORION-EXP-CNT8-TTL/ADJ.

## 3.2.1.8 Quadrature Encoder

In the first case X1 decoding is explained. When *Input A* leads *Input B* in a quadrature cycle, the counter increments on rising edges of *Input A*. When *Input B* leads *Input A* in a quadrature cycle, the counter decrements on the falling edges of *Input A*. At every *Sample Clock* (①, ②, ..., ⑨) the counter value is read out.

Figure 18 shows the resulting increments and decrements for X1 encoding.

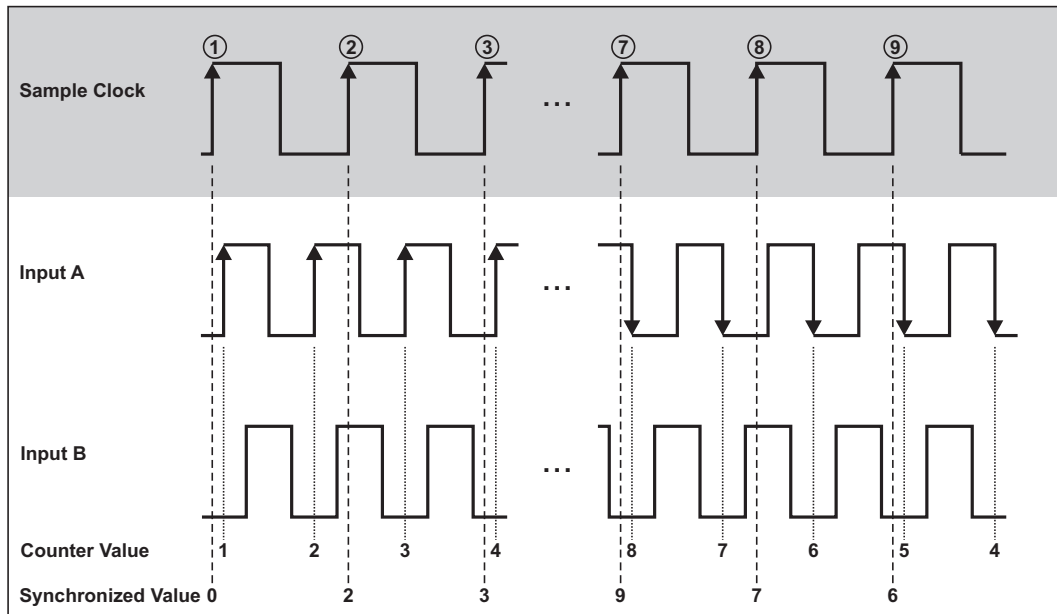

Figure 18: Quadrature Encoder X1 Mode

For X2 encoding the rising edges and the falling edges of *Input A* are used to increment or decrement. The counter increments if *Input A* leads *Input B* and decrements if *Input B* leads *Input A*. This is shown in Figure 19.

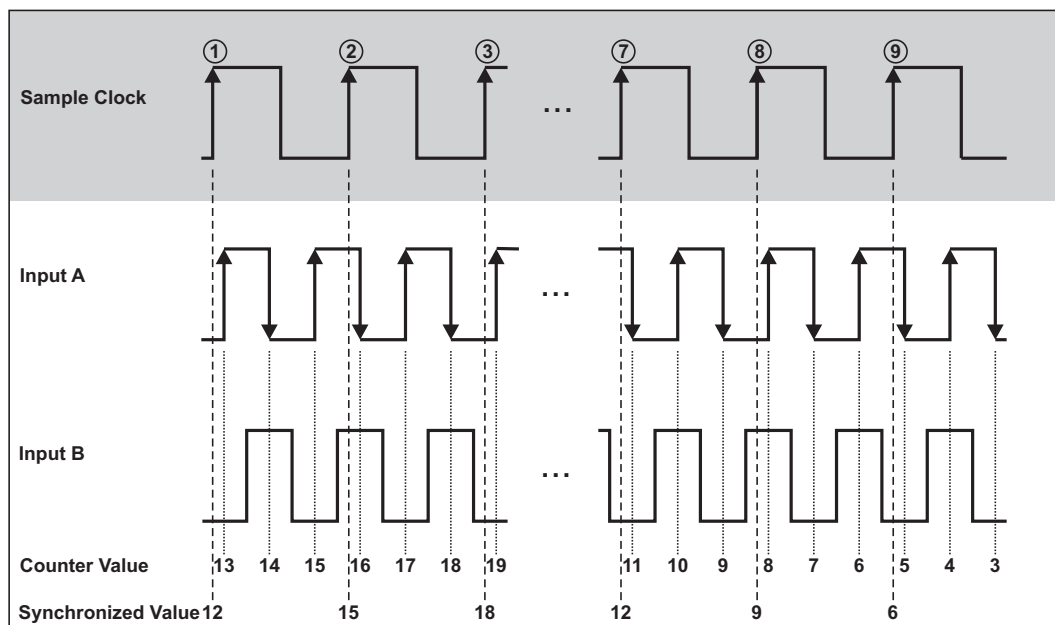

Figure 19: Quadrature Encoder X2 Mode

Similarly, the counter increments or decrements on each edge of *Input A* and *Input B* for X4 decoding. The condition for increment and decrement is the same as for X1 and X2.

# DEWE-ORION-1622-10x

Figure 20 shows the results for X4 encoding.

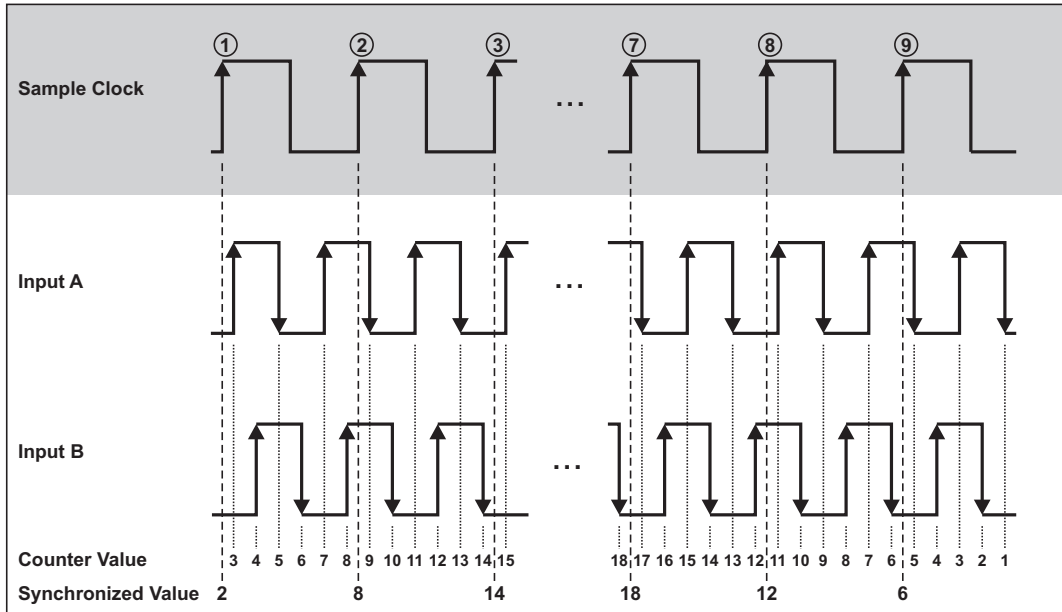

Figure 20: Quadrature Encoder X4 Mode

The third channel *Input Z*, which is also referred as the index channel, causes the counter to be reloaded with zero in a specific phase of the quadrature cycle.

Figure 21 shows the results for X1 encoding with input Z.

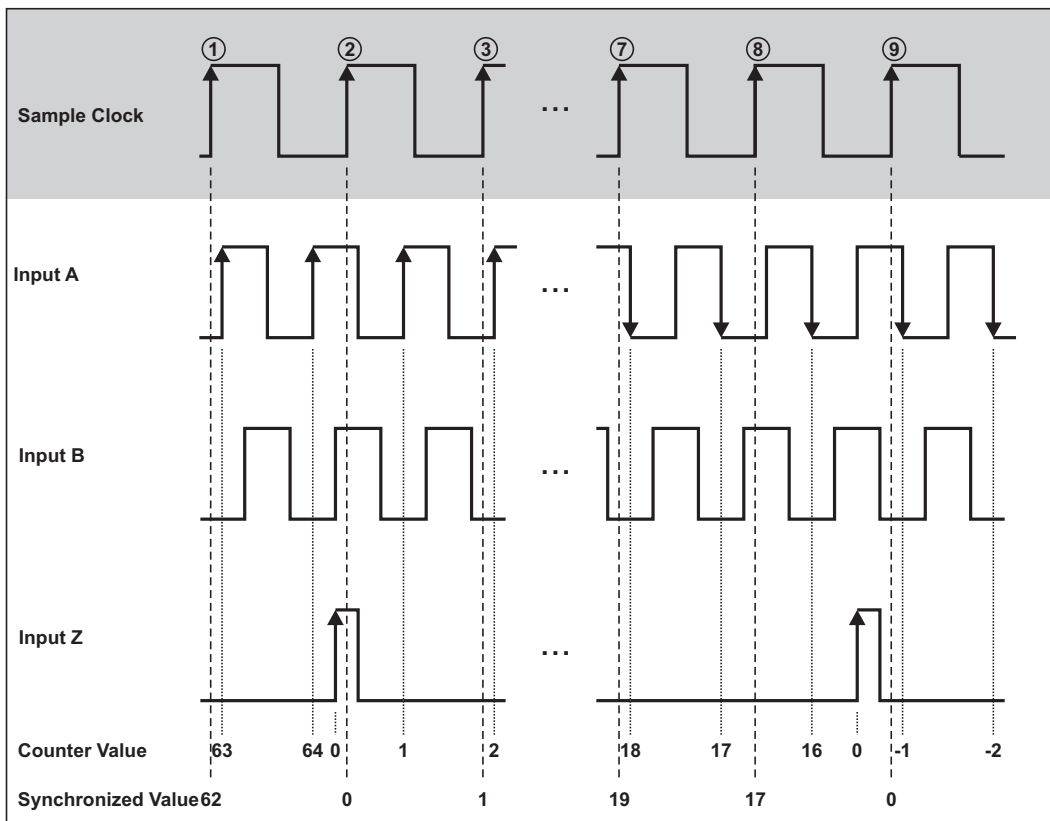
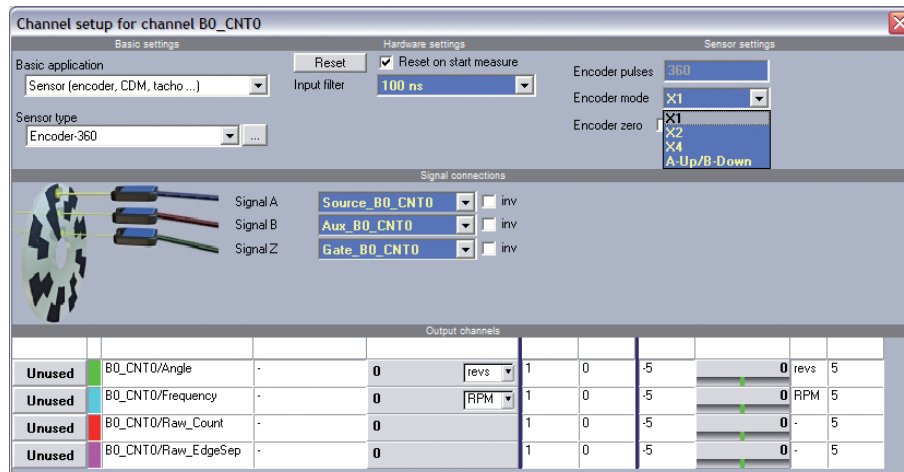

Figure 21: Quadrature Encoder with channel Z



### 3.2.1.9 A-Up/B-Down Encoder

The A-Up/B-Down Encoder supports two inputs, A and B. A pulse on *Input A* increments the counter on its rising edges. A pulse on *Input B* decrements the counter on its rising edges. At every *Sample Clock* (①, ②, ..., ⑨) the counter value is read out.

This situation is shown in Figure 22.

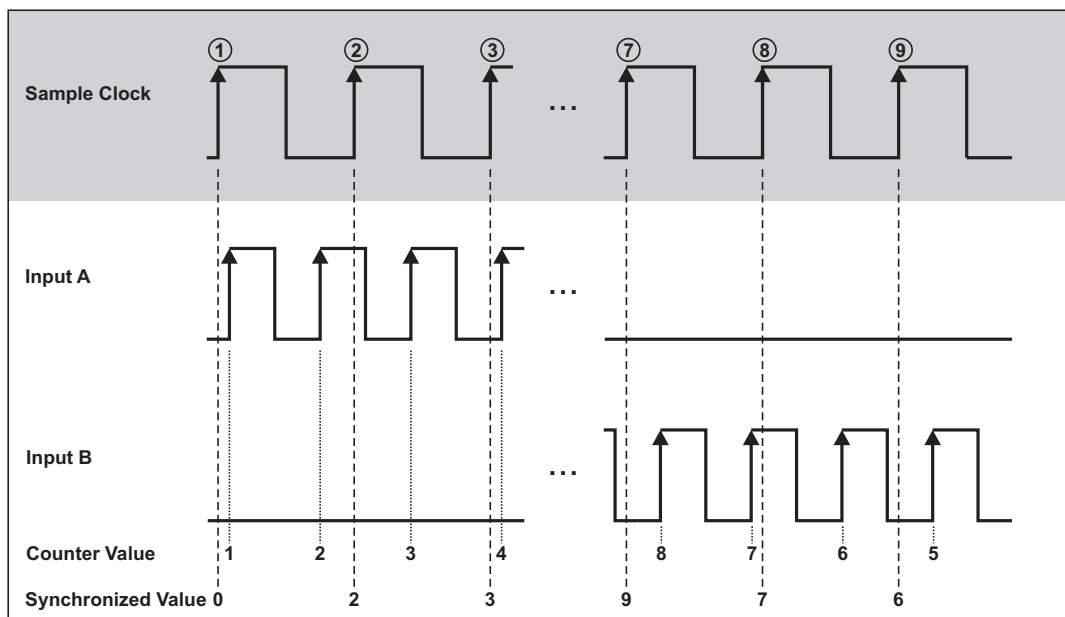
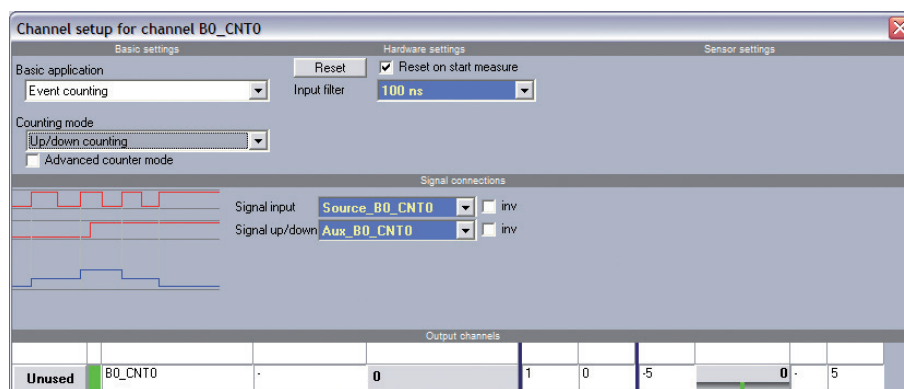

Figure 22: A-Up/B-Down Encoder



# DEWE-ORION-1622-10x

## 3.2.1.10 Frequency Measurement

In general it is possible to take the inverse of a period measurement to get the frequency of the input signal. If the period time measurement is done an inaccuracy of counted internal time base cycles of  $\pm 1$  cycle appears, because the counted cycles of the internal time base depends on the phase of the input signal with respect to the internal time base. For long period times, and therewith low frequencies, the measurement error is negligible. At high frequencies, and therewith short period times, few cycles are counted. In this case the error of  $\pm 1$  cycle becomes significant.

Input Frequency	Number of internal time base cycles	Measurement error of -1 cycle	Measurement error of +1 cycle	Calculated frequency with error of -1 cycle	Calculated frequency with error of +1 cycle
40 kHz	2000	1999	2001	39,98 kHz	40,02 kHz
10 MHz	8	7	9	8,75 MHz	11,25 MHz

Accuracy at period time measurement

For higher precision result a combination of main and sub counter is used internally for getting higher precision at the frequency measurement. The main counter is running on event counting (or encoder mode). The sub counter measures the time between the sample clock and the input event. The sub counter measures exactly the time of the input event with a resolution of 12.5 nsec relative to the sample clock. At every rising edge on *Counter Source* the counter value of the sub counter is stored in a register. At every *Sample Clock* (①, ②, ..., ⑥) the values of both counters are read out.

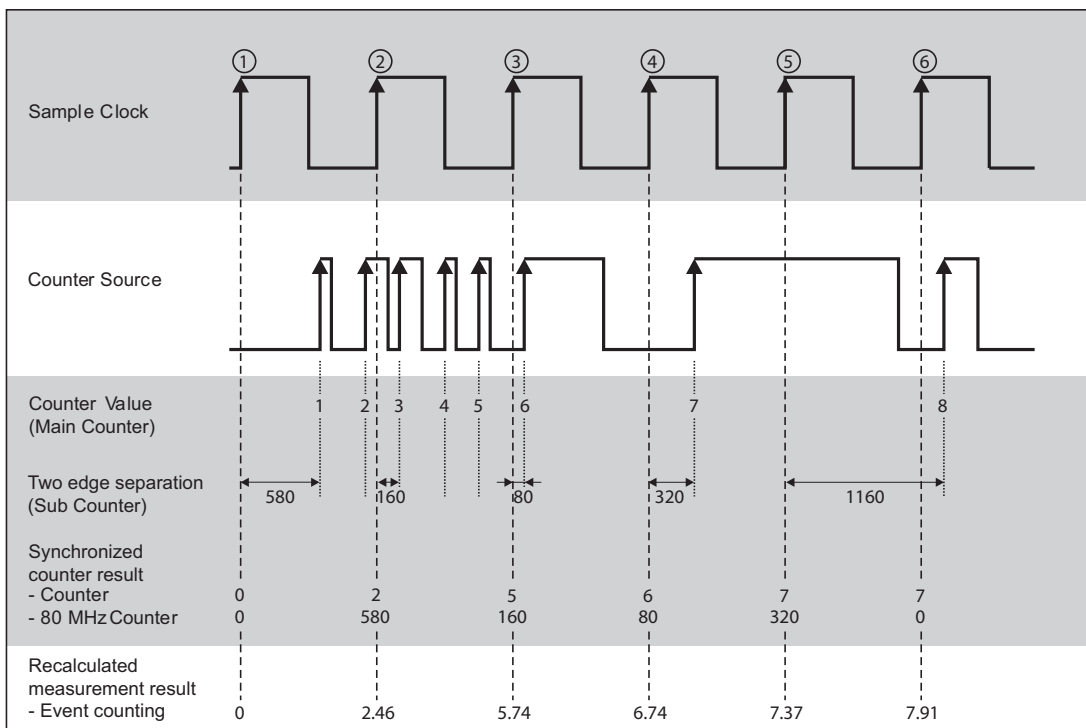

Figure 23: Frequency Measurement

The basic formular for calculating the frequency reads as follows:

$$f = f_{TB} \cdot \frac{EventCnt_n - EventCnt_{n-1}}{\frac{f_{TB}}{SampRate} + EdgeVal_n - EdgeVal_{n-1}}$$

$f$  = calculated frequency

$f_{TB}$  = Internal timebase (80 Mhz)

$EventCnt_n$  = Event counter result of actual sample

$EventCnt_{n-1}$  = Event counter result of previous sample

$SampRate$  = Acquisition rate

$EdgeVal_n$  = Measurement result from edge separation measurement of actual sample

$EdgeVal_{n-1}$  = Measurement result from edge separation measurement of previous sample

As an example the frequency is described on sample point 3. The acquisition rate is assumed with 80 kS/sec.

$$f = 80 \cdot 10^6 \cdot \frac{5 - 2}{\frac{80 \cdot 10^6}{80 \cdot 10^3} + 80 - 160} = 206.869 \text{ kHz}$$

With the measurement concept shown above not only the frequency can be calculated in a precise way. Also the event counter result can be shown in fractions because the exact time when the event occurs at the input is known. The event counting result is recalculated with interpolation to the exact sample point like shown in the diagram above.

Below, the difference of the measurement result is shown. While a standard counter input shows the value up to one sample delayed, the counter input of the ORION calculates the counter result at the exact sample point.

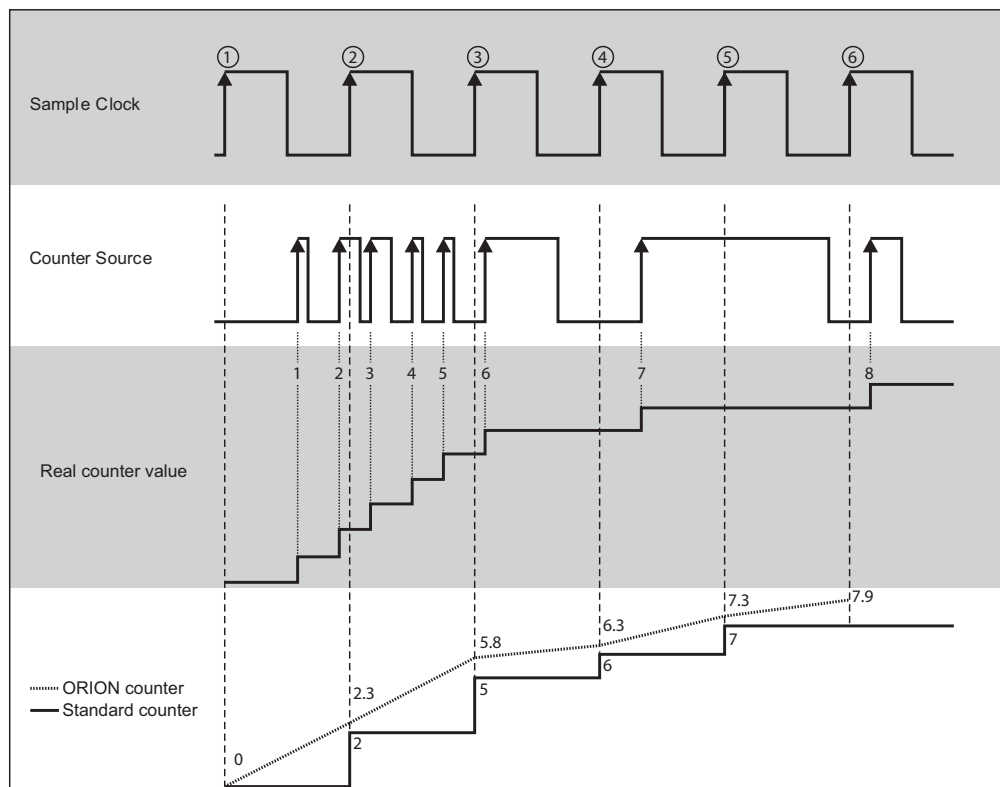

*For low frequency input signals the frequency also can be obtained by measure the period time and take its inverse without more inaccuracy.*

# DEWE-ORION-1622-10x

## 3.2.2 Miscellaneous counter functions

### 3.2.2.1 Filters

Each ORION-EXP-CNT8 input has a digital filter, which can be set to various gate times. If the gate time is set to "Off", no filter is on the input signal.

The filter circuit samples the input signal on each rising edge of the internal time base. If the input signal maintains his state for at least the gate time, the new state is propagated. As an effect the signal transition is shifted by the gate time.

Figure 24 demonstrates the function of the filter.

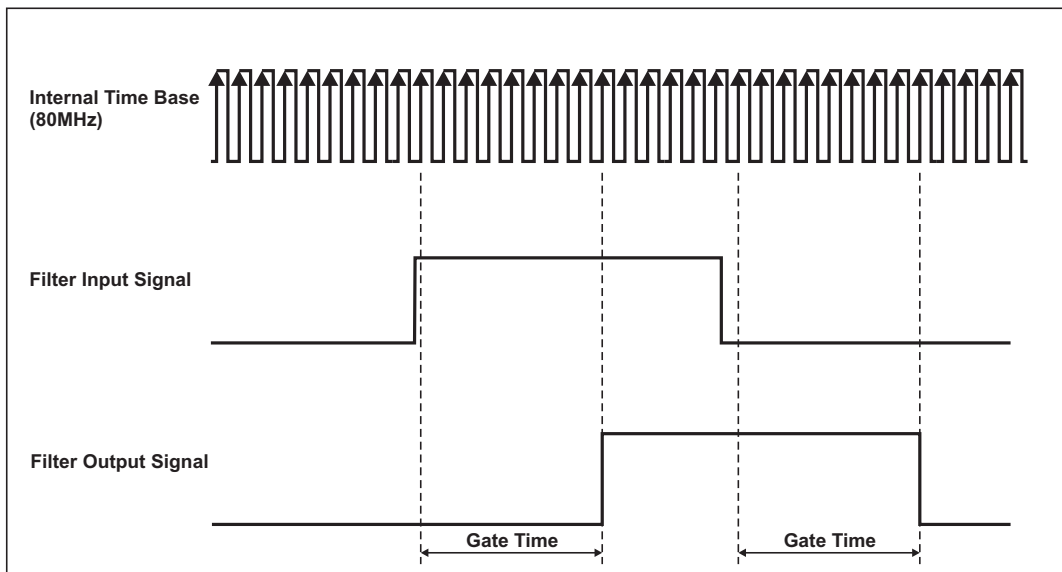

Figure 24: Filters

The intent of the filter is to eliminate unstable states, e.g. glitches, chatter, ..., which may appear on the input signal, as shown in Figure 25.

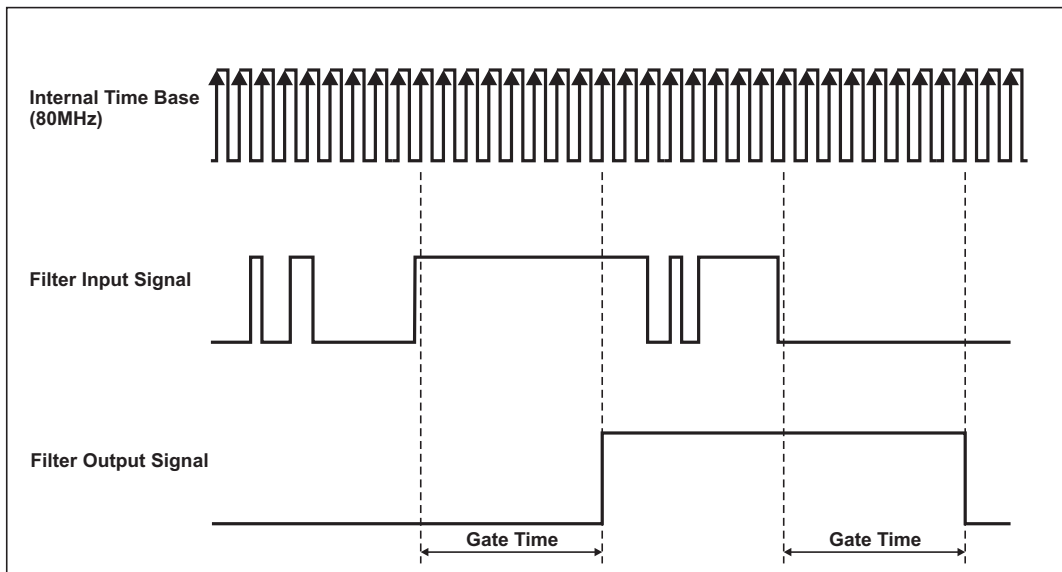

Figure 25: Input signal with chatter

It can be chosen between eight filter settings: Off, 100 ns, 200 ns, 500 ns, 1  $\mu$ s, 2  $\mu$ s, 4  $\mu$ s and 5  $\mu$ s. Two examples of filter settings are described.

# DEWE-ORION-1622-10x

The 100 ns filter will pass all pulse widths (high and low) that are 100 ns or longer. It will block all pulse widths that are 75 ns or shorter. The 5  $\mu$ s filter will pass all pulse widths (high and low) that are 5  $\mu$ s or longer and will block all pulse widths that are 4.975  $\mu$ s or shorter.

The internal sampling clock (time base) is 80 MHz, so the period time amounts 12.5 ns. Pulse widths between gate time minus two internal time base period times may or may not pass, depending on the phase of the input signal with respect to the internal time base.

Properties of all filter settings:

Filter settings	Pulse width to pass	Pulse width to be blocked
100 ns	100 ns	75 ns
200 ns	200 ns	175 ns
500 ns	500 ns	475 ns
1 $\mu$ s	1 $\mu$ s	975 ns
2 $\mu$ s	2 $\mu$ s	1.975 $\mu$ s
4 $\mu$ s	4 $\mu$ s	3.975 $\mu$ s
5 $\mu$ s	5 $\mu$ s	4.975 $\mu$ s
Off	-	-

*Filter Gate Times*

### 3.2.2.2 Reset on start measure

Usually all counters are reset at the start of data acquisition, i.e. the counter value is set to zero at the start of data acquisition. In some applications this is not required. An angle encoder for example is adjusted to the physical zero position at the beginning of a test procedure. By resetting the counter at every start of the measurement this adjustment get lost. Without this reset the counter is also active if the acquisition is interrupted between the test cycles. As a result the counter types out the absolute angle position at the measurement output all the time.

### 3.2.2.3 Count Direction

As default setting the count direction is in up-counting mode. Every rising edge at the input will increase the counter value. The DEWE-ORION-1622-10x supports also down counting without the need of an additional input like in the up/down counting mode.

### 3.2.2.4 No new value available

Especially in every kind of input period time measurement mode (also pulse width or two pulse edge separation measurement) there may be new information between two samples. Also measuring the line frequency of about 50 Hz with a sample rate of 10 kSamples/sec means, that only after every 200th measurement new input frequency information is available. Another example is the measurement on rotating machines if the sensor output frequency is lower than the sample rate. Depending on the application the DEWE-ORION-1622-10x can choose between two different output data settings:

- Repeat last value: last measured cycle time is taken until a new measured cycle time is available.
- Make zero value: as soon as no input information is available the output is set to Zero.

# DEWE-ORION-1622-10x

## 4 Specifications

### 4.1 Analog input

Analog input		
<b>Channel characteristics</b>		
Number of channels	16, simultaneously sampled	
Input configuration	Single ended with remote sense	
Resolution	22-bit, nominal	
Type of ADC	Delta-sigma	
Sampling rate	102.4 kS/s per channel	
Data throughput	1.6 MS/s max.	
Oversampling, for sample rate (fs)		
Frequency accuracy	±35 ppm	
100 S/s ≤ f <sub>s</sub> ≤ 51.2 kS/s	256 f <sub>s</sub>	
51.2 kS/s < f <sub>s</sub> ≤ 102.4 kS/s	128 f <sub>s</sub>	
Input signal range	±10 V <sub>peak</sub>	
FIFO buffer size	4096 samples	
Data transfers	DMA	
<b>Transfer characteristics</b>		
DC accuracy	% of reading	% of range
±10 V	0.05 %	0.01 %
Gain drift	±15 ppm/K	
<b>Amplifier characteristics</b>		
Input impedance (ground referenced)	10 MΩ in parallel with 60 pF	
Overvoltage protection	±30 V	
Common mode rejection (CMR) with AISense		
f <sub>in</sub> < 1 kHz	> 60 dB, typ.	
Flatness digital filter		
1 kS/s ≤ f <sub>s</sub> ≤ 51.2 kS/s	-0.035 dB to +0.01 dB, DC to 0.475 f <sub>s</sub>	
51.2 kS/s < f <sub>s</sub> ≤ 102.4 kS/s	-0.035 dB to +0.01 dB, DC to 0.45 f <sub>s</sub>	
-3 dB Bandwidth digital filter		
1 kS/s ≤ f <sub>s</sub> ≤ 51.2 kS/s	0.494 f <sub>s</sub>	
51.2 kS/s < f <sub>s</sub> ≤ 102.4 kS/s	0.49 f <sub>s</sub>	
Analog bandwidth		
-1 dB Bandwidth	90 kHz	
-3 dB Bandwidth	160 kHz	
<b>Maximum working voltage</b>		
Channel-to-ground, channel-to-channel	10 V, installation category I	
Max. working voltage refers to the signal voltage plus common-mode voltage.		

# DEWE-ORION-1622-10x

Dynamic characteristics	
Alias-free bandwidth (passband) 1 kS/s $\leq f_s \leq$ 51.2 kS/s 51.2 kS/s $< f_s \leq$ 102.4 kS/s	DC (0 Hz) to 0.42 $f_s$ DC (0 Hz) to 0.32 $f_s$
Alias rejection 1 kS/s $\leq f_s \leq$ 51.2 kS/s 51.2 kS/s $< f_s \leq$ 102.4 kS/s	-95 dB -92 dB
Signal to noise 1 kS/s $\leq f_s \leq$ 51.2 kS/s 51.2 kS/s $< f_s \leq$ 102.4 kS/s	102 dB 99 dB
Spurious free dynamic range 1kS to 51.2 kS/s 51.2kS to 102.4 kS/s	126 dB 121 dB
THD (1kS/s $\leq f_s \leq$ 102.4 kS/s)	0 dB <sub>F<sub>S</sub></sub> input $<$ -90 dB -20 dB <sub>F<sub>S</sub></sub> input $<$ -100 dB -60 dB <sub>F<sub>S</sub></sub> input $<$ -60 dB
Crosstalk (channel separation) $f_{in}$ 0 to 10 kHz $f_{in}$ 10 to 50 kHz	105 dB 90 dB
Typical interchannel gain mismatch	$\pm$ 0.002 dB
Filter delay through ADC 1 kS/s $\leq f_s \leq$ 51.2 kS/s 51.2 kS/s $< f_s \leq$ 102.4 kS/s	12 / $f_s$ 9 / $f_s$
Inter channel phase mismatch	$0.03^\circ * f_{in}$ (kHz) + 0.1 $^\circ$

Idle channel noise

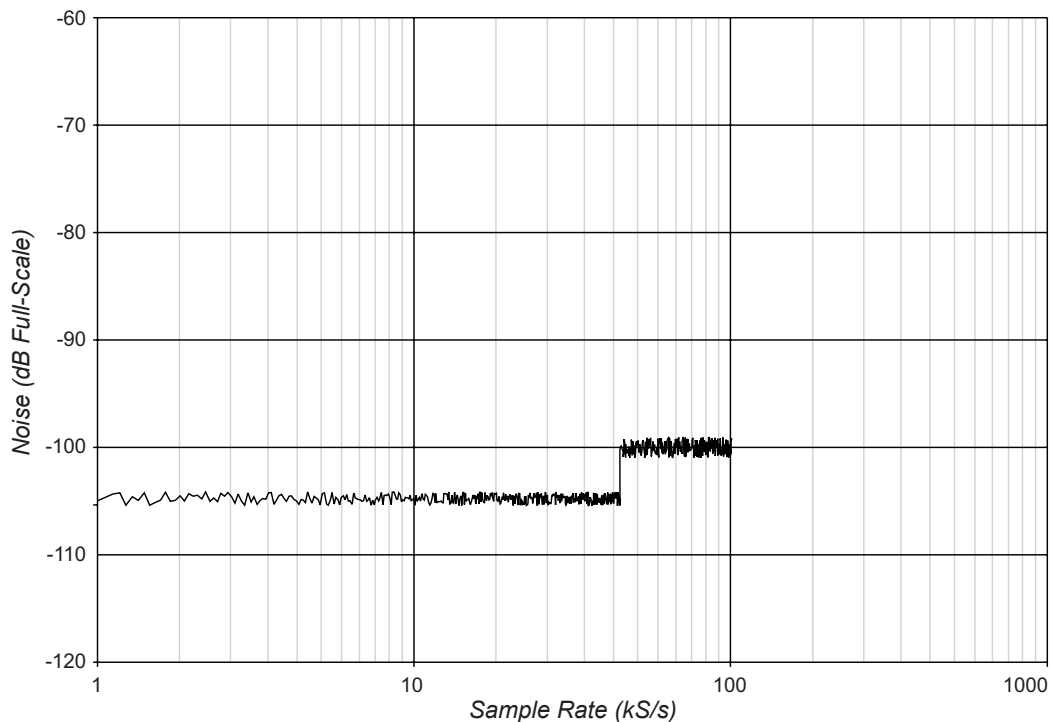

# DEWE-ORION-1622-10x

Spectral noise - Idle input - 10 averages 16k lines @ 50 kHz sampling rate

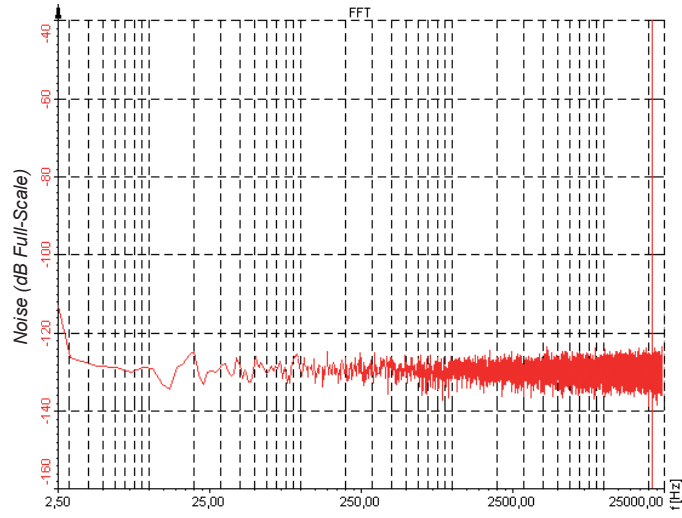

Spectral noise - Idle input - 10 averages 16k lines @ 100 kHz sampling rate

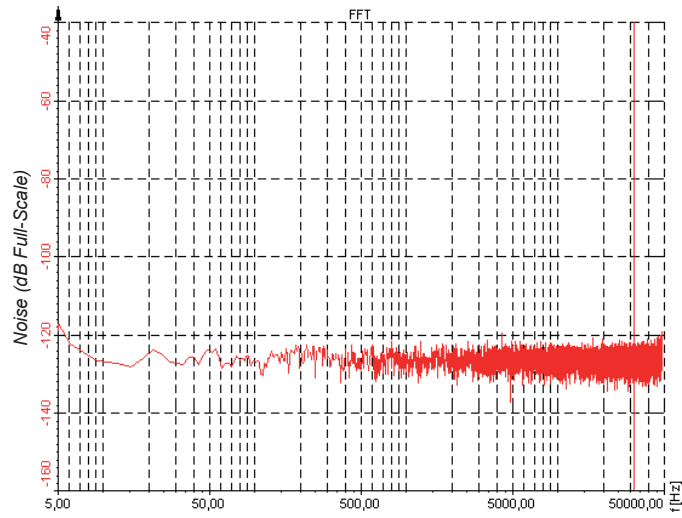

## 4.2 Digital and Counter input

<b>Digital and Counter input</b>	
Counter resolution	32-bit
Counter time base	80 MHz
Time base accuracy	35 ppm
Maximum input frequency	40 MHz
<b>Input signal characteristic main board</b>	
Compatibility	TTL/CMOS
Configuration	Pull-up with 100 kOhm
Input low level	-0.7 V to 0.8 V
Input high level	2 V to 5 V
Input low current	< -50 $\mu$ A
Input high current	< 10 $\mu$ A
Input capacitance	< 5 pF
Overvoltage protection (DI 0 to DI 7)	$\pm$ 25 V continuous
Overvoltage protection (DI 8 to DI 15)	-1 to 6 V
<b>Input signal characteristic CLK and Trigger</b>	
Compatibility	TTL Schmitt trigger
Configuration	Pull-up with 100 kOhm
Input low level	-0.7 V to 2 V
Input high level	3 V to 5 V
Input low current	< -50 $\mu$ A
Input high current	< 10 $\mu$ A
Input capacitance	< 5 pF
Overvoltage protection	-1 to 6 V
<b>Input signal characteristic expansion board with TTL input</b>	
Compatibility	TTL/CMOS
Configuration	Pull-up with 100 kOhm
Input low level	-0.7 V to 0.8 V
Input high level	2 V to 5 V
Input low current	< -50 $\mu$ A
Input high current	< 10 $\mu$ A
Input capacitance	< 5 pF
Overvoltage protection	$\pm$ 25 V
<b>Input signal characteristic expansion board with adjustable input</b>	
Compatibility	Adjustable trigger levels
Configuration	Symmetric differential
Input coupling	DC / AC (1Hz)
Input impedance (ground referenced)	1 MOhm / 5 pF
Bandwith (-3dB)	5 MHz
Trigger adjustment range	0 to 40 V
Trigger resolution	40 mV
Trigger level accuracy	$\pm$ 100 mV $\pm$ 1% of trigger level
Common voltage range	-35 to 50V
Common mode rejection ratio	>40 dB
Overvoltage protection	$\pm$ 100 V continuous
Max. DC level @AC coupling	$\pm$ 50 V continuous
<b>Input signal characteristic with isolated inputs</b>	
Compatibility	CMOS
Configuration	Isolated input
Input low level	$U_{IN} < 1.8$ V
Input high level	$U_{IN} > 3.2$ V
Input high current @ 5 V $U_{IN}$	< 3.5 mA
Input high current @ 30 V $U_{IN}$	< 7 mA
Propagation delay	< 160 nsec
Bandwidth	3 MHz
Overvoltage protection	35 V continuous (65 V peak)
Isolation voltage (channel to channel)	100 V
Isolation voltage (input to output)	250 V

# DEWE-ORION-1622-10x

## 4.3 Digital and clock divider output

Digital and clock divider out	
Compatibility	TTL/CMOS
Characteristic	
Low voltage level	< 0.4 V @ 4 mA load
High voltage level	> 3 V @ 4 mA load
Output current	
Sink (low level)	-20 mA
Source (high level)	20 mA
Output impedance	50 Ohm

## 4.4 CAN interface

CAN interface	
Specification	CAN 2.0B
Physical layer	High speed
Listen only mode	Supported
Galvanic isolation	Not isolated
Bus pin fault protection	±36 V
ESD protection	12 kV (HBM)
CAN transceiver	SNHVD235
PCI data transfere mode	DMA with SW pooling
ORION-CAN	
5 V DSUB	max. 500 mA per channel (self healing fuse)
12 V DSUB	max. 200 mA for both connectors (self healing fuse)
5 V LEMO	max. 1.1 A (self healing fuse)
12 V LEMO	max. 200 mA (self healing fuse)

## 4.5 Power requirements

Orion Type	I <sub>12V</sub> [mA]	I <sub>5V</sub> [mA]	I <sub>3.3V</sub> [mA]	P <sub>tot.</sub> [Watt]
Orion-1622-100	---	1240	---	6,2
Orion-1622-101	---	1310	---	6,6
Orion-1622-102	---	1360	---	6,8
Orion-1622-103	---	1430	---	7,2
Orion-1622-104	---	1560	---	7,8
Orion-1622-105	---	1630	---	8,2
Orion-3222-100	---	2230	---	11,2
Orion-3222-101	---	2300	---	11,5

This table does not include the current taken from the I/O connectors like CAN or analog input.

## 4.6 General Specifications

<b>General Specifications</b>	
<b>Environmental</b>	
Operating temperature	0 to 50 °C
Storage temperature	-20 to 70 °C
Relative humidity	10 to 90%, non condensing
Maximum altitude	2000 m
Pollution degree (indoor use only)	2
<b>Physical</b>	
Dimensions (not including connectors)	17.5 x 10.7 cm (6.9 x 4.2 in.)
Analog input connector (main board)	68-pin SCSI male (AMP 174341-5)
Counter input connector (expansion)	68-pin SCSI male (Honda PCS-68LMD)
CAN input connector	
SUBD	2 x SUB-D 9-pin male
Lemo	7-pin Lemo connector female (Type: EPG.0B.307.HLN)

# DEWE-ORION-1622-10x

---

Notes

# CE-Certificate of conformity



Manufacturer: **DEWETRON Elektronische Messgeraete Ges.m.b.H.**

Address: **Parkring 4  
A-8074 Graz-Grambach Austria**

Tel.: +43 316 3070 0

Fax: +43 316 3070 90

e-mail: sales@dewetron.com

http://www.dewetron.com

Name of product: **DEWE-ORION-1622-10x**

Kind of product: *A/D board*

The product meets the regulations of the following EC-directives:

### **73/23/EEC**

**"Directive on the approximation of the laws of the Member States relating to electrical equipment designed for use within certain voltage limits amended by the directive 93/68/EEC"**

### **89/336/EEC**

**"Directive on the approximation of the laws of the Member States relating to electromagnetic compatibility amended by the directives 91/263/EEC, 92/31/EEC, 93/68/EEC and 93/97/EEC"**

The accordance is proved by the observance of the following standards:

<b>L V E M C</b>	<b>Safety</b>	IEC/EN 61010-1:1992/93 IEC/EN 61010-2-031	IEC 61010-1:1992/300 V CATIII PoI. D. 2 IEC 1010-2-031
	<b>Emissions</b>	EN 61000-6-4	EN 55011 Class B
	<b>Immunity</b>	EN 61000-6-2	Group standard

**Graz, April 28, 2010**

Place / Date of the CE-marking

  
Dipl.-Ing. Roland Jeutter / Managing director

# Notes

---