



DEWETRON

▼

DEWE2-A4

TECHNICAL REFERENCE MANUAL

▼

WELCOME TO THE WORLD OF DEWETRON!

Congratulations on your new device!
It will supply you with accurate, complete and reproducible measurement results for your decision making.
Look forward to the easy handling and the flexible and modular use of your DEWETRON product and draw upon more than 30 years of DEWETRON expertise in measurement engineering.



ISO9001



THE MEASURABLE DIFFERENCE.

Copyright © DEWETRON GmbH

This document contains information which is protected by copyright. All rights are reserved. Reproduction, adaptation, or translation without prior written permission is prohibited, except as allowed under the copyright laws.

All trademarks and registered trademarks are acknowledged to be the property of their owners.

Preface

Thank you!

Thank you very much for your investment in DEWETRON's unique data acquisition systems. These are top-quality instruments which are designed to provide you years of reliable service. This guide has been prepared to help you get the most from your investment, starting from the day you take it out of the box, and extending for years into the future.

This guide includes important startup notes, as well as safety notes and information about keeping your DEWETRON system in good working condition over time. However, this manual cannot and is not intended to replace adequate training.

This documentation contains operating as well as safety and care instructions that must be observed by the user. Faultless operation can only be guaranteed by observing these instructions.

Intended use

This product is used for measuring of different physical and/or electrical sizes (depending on model and/or configuration).

The connection is depending on the model and/or configuration and is done via safety banana plugs, BNC connectors, D-SUB connectors, SMB connectors, μ dot connectors, LEMO® connectors or RJ-45 connectors.



PREFACE

Notes



TABLE OF CONTENTS

Preface	3
Thank you!	3
Intended use	3
Safety	7
Safety instructions	7
General safety instructions	7
Electrical safety instructions	8
Ambient safety notices	8
Safety notices during operation	9
Standards and norms	9
Typographic conventions	9
Safety and warning notices	9
Notices	10
Symbols	10
Introduction	11
System overview	11
Environmental considerations	12
Problematic network stacks	12
Warranty information	12
Legal information	12
Restricted rights legend	12
Legal disclaimer	12
Printing history	13
System setup	15
Key facts	15
System specifications	15
Dimensions	16
Connections and ports	17
TRION series modules overview	19
Analog modules	19
Digital modules	19
Power modules	20
Installing a TRION module	21
Power supply	22
Internal DC power supply	22
External AC/DC power supply	22

DW2-PS-DC-BUFFER (option)	23
System recovery	23
Synchronization	23
Channel expansion with TRIONet	23
Network with multiple systems	24
Absolute time synchronization	24
Notes	26

Maintenance and service	27
Service interval	27
Cleaning	27
Updates	27
Windows and antivirus/security software	27
Software updates	27
Training	28
Calibration	28
Support	28
Service and repairs	28

Certificate of conformity	29
--	-----------

Glossary	31
-----------------------	-----------



TABLE OF CONTENTS

Notes

Safety

Safety instructions

The following section contains warning and safety instructions that must be observed by the user. Faultless operation can only be guaranteed if these instructions are observed.

General safety instructions

- ▶ Use this system under the terms of the specifications only to avoid any possible danger. If the unit is used in a manner not specified by the manufacturer the protection can be impaired.
- ▶ Maintenance is to be executed by qualified staff only.
- ▶ DO NOT use the system if equipment covers or shields are removed. If you assume the system is damaged, have it examined by authorized personnel only.
- ▶ Any other use than described above may damage your system and is attended with dangers like shortcut, fire or electric shocks.
- ▶ The whole system must not be changed, rebuilt or opened (except for changing TRION modules).
- ▶ Reinstall filler panels of unused TRION slots to guarantee proper cooling of the installed modules. The warranty is void if the modules overheat due to missing filler panels.
- ▶ If you assume a more riskless use is not provided anymore, the system has to be rendered inoperative and should be protected against inadvertent operation. It is assumed that a more riskless operation is not possible anymore, if
 - the system is damaged obviously or causes strange noises.
 - the system does not work anymore.
 - the system has been exposed to long storage in adverse environmental.
 - the system has been exposed to heavy shipment strain.
- ▶ The warranty is void if damages caused by disregarding this manual. For consequential damages NO liability will be assumed.
- ▶ The warranty is void if damages to property or persons caused by improper use or disregarding the safety instructions.
- ▶ Unauthorized changing or rebuilding the system is prohibited due to safety and permission reasons (CE).
Exception: changing TRION modules.
- ▶ Prevent using metal bare wires as there is a risk of short-circuit and fire hazard.
- ▶ DO NOT use the system before, during or shortly after a thunderstorm (risk of lightning and high energy overvoltage). An advanced range of application under certain conditions is allowed with therefore designed products only. For details refer to the specifications.
- ▶ Make sure that your hands, shoes, clothes and as well as the floor, the system or measuring leads, integrated circuits etc. are dry.
- ▶ Use measurement leads or measurement accessories aligned to the specification of the system only. Fire hazard in case of overload.
- ▶ Do not disassemble the system. There is a high risk of getting a perilous electric shock. Capacitors still might be charged, even the system has been removed from the power supply.
- ▶ The measuring systems are not designed for use at humans and animals.
- ▶ Contact a professional if you have doubts about the method of operation, safety or the connection of the system.
- ▶ Handle the product with care. Shocks, hits and dropping it even from an already lower level may damage your system.

For exact values refer to the enclosed specifications.

SAFETY

- ▶ Also consider the detailed technical reference manual as well as the security advices of the connected systems.

Electrical safety instructions

- ▶ With this product, only use the power cable delivered or defined for the host country.
- ▶ DO NOT connect or disconnect sensors, probes or test leads, as these parts are connected to a voltage supply unit.
- ▶ The system is grounded via a protective conductor in the power supply cord. To avoid electric shocks, the protective conductor has to be connected with the ground of the power network. Before connecting the input or output connectors of the system, make sure that there is a proper grounding to guarantee potential free usage. For countries, in which there is no proper grounding, refer to your local legally safety regulations for safety use.
- ▶ DC systems: Every DC system has a grounding connected to the chassis (yellow/green safety banana plug).
- ▶ Note the characteristics and indicators on the system to avoid fire or electric shocks. Before connecting the system, carefully read and understand the corresponding specifications in the product manual.
- ▶ The inputs are not, unless otherwise noted (CATx identification), for connecting to the main circuits of category II, III and IV. The measurement category can be adjusted depending on module configuration.
- ▶ The power cord or the main power switch separates the system from the power supply. Do not block the power cord or main switch, since it has to be accessible for the users.
- ▶ Any direct voltage output is protected with a fuse against short cut and reverse-polarity, but is NOT galvanically isolated (except it is explicit marked on the system).
- ▶ Supply overvoltage category is II.
- ▶ The system must be connected and operated to an earthed wall socket at the AC mains power supply only (except for DC systems).
- ▶ DO NOT touch any exposed connectors or components if they are live wired. The use of metal bare wires is not allowed. There is a risk of short cut and fire hazard.
- ▶ The assembly of the system is equivalent to protection class I. For power supply, only the correct power socket of the public power supply must be used, except the system is DC powered.
- ▶ Be careful with voltages >25 VAC or >35 VDC. These voltages are already high enough in order to get a perilous electric shock by touching the wiring.
- ▶ Maximum input voltage for measuring cards are 70 VDC and 46.7 V_{PEAK}
- ▶ Avoid operation in the immediate vicinity of:
 - high magnetic or electromagnetic fields
 - transmitting antennas or high-frequency generatorsFor exact values refer to the enclosed specifications.
- ▶ The electrical installations and equipments in industrial facilities must be observed by the security regulations and insurance institutions.

Ambient safety notices

- ▶ This product is intended for use in industrial locations. As a result, this product may cause interference if used in residential areas. Such use must be avoided unless the user takes special measures to reduce electromagnetic emissions to prevent interferences to the reception of radio and television broadcasts.
- ▶ Do not switch on the system after transporting it from a cold into a warm room and vice versa. The thereby created condensation may damage your system. Acclimatise the system unpowered to room temperature.
- ▶ Any use in wet rooms, outdoors or in adverse environmental condition is not allowed. Adverse environmental conditions are:
 - Moisture or high humidity
 - Dust, flammable gases, fumes or dissolver

- Thunderstorm or thunderstorm conditions (except assembly PNA)
- Electrostatic fields etc.
- ▶ DO NOT use the system in rooms with flammable gases, fumes or dust or in adverse environmental conditions.
- ▶ Direct exposure of any DEWETRON product to strong sunlight or other heat radiation shall be prevented, as this could excessively heat up the product and lead to permanent damage of the product.
- ▶ The use of the measuring system in schools and other training facilities must be observed by skilled personnel.

Safety notices during operation

- ▶ During the use of the system, it might be possible to access another parts of a more comprehensive system. Read and follow the safety instructions provided in the manuals of all other components regarding warning and security advices for using the system.
- ▶ The product heats during operation. Make sure there is adequate ventilation. Ventilation slots must not covered. Only fuses of the specified type and nominal current may be used. The use of patched fuses is prohibited.

Standards and norms

This product has left the factory in safety-related flawless and proper condition.

In order to maintain this condition and guarantee safety use, the user has to consider the security advices and warnings in this manual.

EN 61326-3-1:2008

IEC 61326-1 applies to this part of IEC 61326 but is limited to systems and equipment for industrial applications intended to perform safety functions as defined in IEC 61508 with SIL 1-3.

The electromagnetic environments encompassed by this product family standard are industrial, both indoor and outdoor, as described for industrial locations in IEC 61000-6-2 or defined in 3.7 of IEC 61326-1.

Equipment and systems intended for use in other electromagnetic environments, for example, in the process industry or in environments with potentially explosive atmospheres, are excluded from the scope of this product family standard, IEC 61326-3-1.

Devices and systems according to IEC 61508 or IEC 61511 which are considered as “operationally welltried”, are excluded from the scope of IEC 61326-3-1.

Fire-alarm and safety-alarm systems, intended for protection of buildings, are excluded from the scope of IEC 61326-3-1.

Typographic conventions

Safety and warning notices

WARNING



Indicates a hazardous situation that, if not avoided, could result in death or serious injury.

CAUTION



Indicates a hazardous situation that, if not avoided, could result in minor or moderate injury.

SAFETY

Notices

NOTICE

This text indicates situations or operation errors which could result in property damage or data loss.

INFORMATION

This text indicates important information or operating instructions. Not observing these instructions could inhibit or impede you from successfully completing the tasks described in this documentation.

Symbols



Denotes a warning that alerts you to take precautions to avoid injury. When this symbol is shown on the product, refer to the technical reference manual.



Indicates hazardous voltages.



Observe precautions for handling electrostatic sensitive devices.

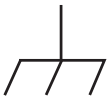

Indicates the chassis terminal.

Introduction

System overview

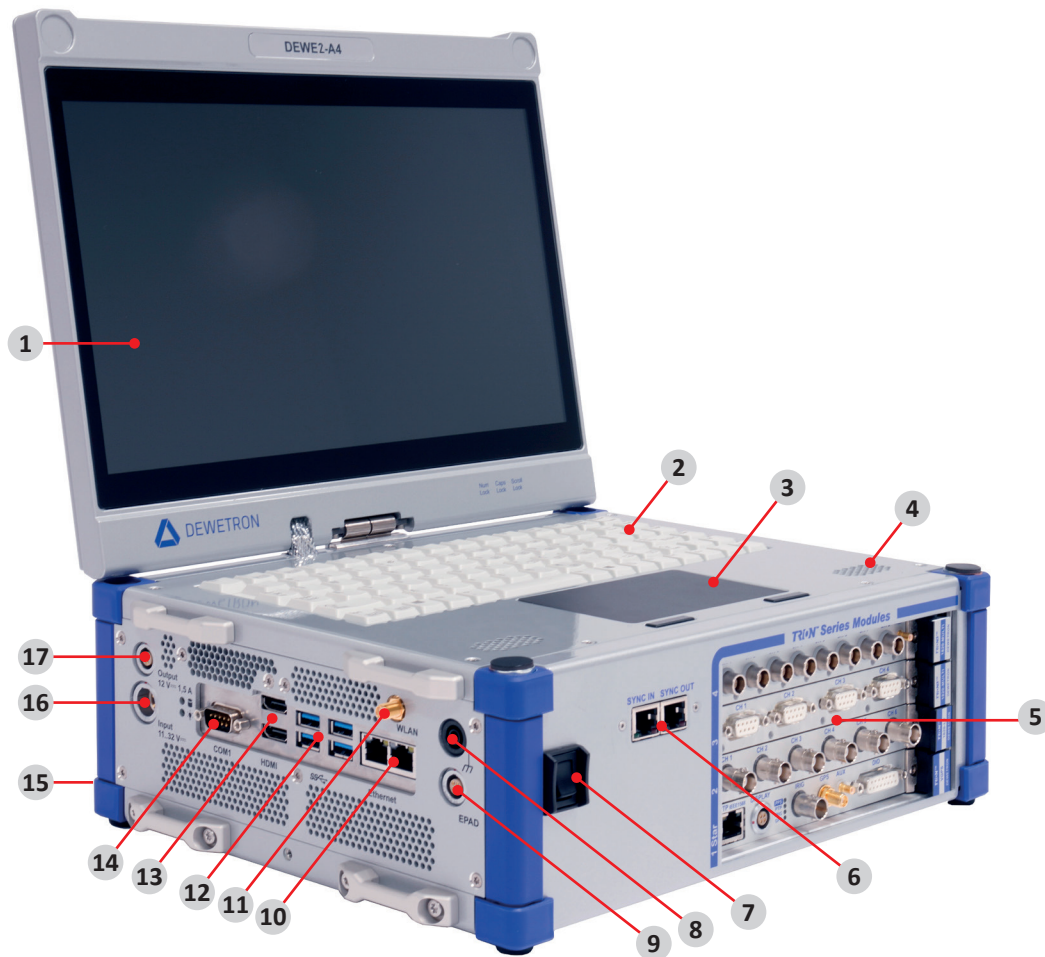

Fig. 1: DEWE2-A4 overview

- | | | | |
|----|-------------------------------|-----|---|
| 1. | 13" TFT display (1920 x 1080) | 10. | Dual LAN GBit connectors |
| 2. | Integrated keyboard | 11. | WLAN antenna |
| 3. | Touchpad | 12. | USB 3.0 interface connectors |
| 4. | Integrated speakers | 13. | HDMI connectors |
| 5. | TRION series modules slots | 14. | RS-232 interceace connector (COM1) |
| 6. | TRION SYNC-BUS | 15. | SSD drive bay for operating system and application software (on backside) |
| 7. | Power on/off switch | 16. | Power supply input connector (EGJ.2B.302) |
| 8. | Chassis terminal | 17. | Power supply output for accessories 12 VDC (LEMO EGG.1B.302) |
| 9. | EPAD2 interface connector | | |

INTRODUCTION

INFORMATION

The amount and location of the connectors might vary from system to system and depend on the system configuration.

Environmental considerations

The following information refers to the environmental impact of the product and the product end-of-life handling. Observe the following guidelines when recycling a DEWETRON system:

▶ System and components recycling



The production of these components has required the extraction and use of natural resources. The substances contained in the system could be harmful to your health and to the environment if the system is improperly handled at its end of life. Please recycle this product in an appropriate way to avoid an unnecessary pollution of the environment and to keep natural resources.

This symbol indicates that this system complies with the European Union's requirements according to Directive 2002/96/EC on Waste of Electrical and Electronic Equipment (WEEE). Further information about recycling can be found on the DEWETRON website (www.dewetron.com).

▶ Restriction of hazardous substances

This product has been classified as Monitoring and Control equipment, and is outside the scope of the 2011/65/EU RoHS Directive. This product is known to contain lead.

Problematic network stacks

Often intrusive IT software or network processes can interfere with the primary function of the DEWETRON system: to record data. Therefore we recommend strongly against the installation of IT/MIS software and running their processes on any DEWETRON data acquisition system, and cannot guarantee the performance of our systems if they are so configured.

Warranty information

A copy of the specific warranty terms applicable to your DEWETRON product and replacement parts can be obtained from your local sales and service office.

Legal information

Restricted rights legend

Use Austrian law for duplication or disclosure.

DEWETRON GmbH
Parkring 4
8074 Grambach
Austria

TRION and OXYGEN are trademarks of DEWETRON GmbH.

Any other trademarks and registered trademarks are acknowledged to be the property of their owners.

Legal disclaimer

The information contained in this document is subject to change without notice.

DEWETRON GmbH (DEWETRON) shall not be liable for any errors contained in this document.

DEWETRON MAKES NO WARRANTIES OF ANY KIND WITH REGARD TO THIS DOCUMENT, WHETHER EXPRESS OR IMPLIED. DEWETRON SPECIFICALLY DISCLAIMS THE IMPLIED WARRANTIES OF MERCHANTABILITY AND FITNESS FOR A PARTICULAR PURPOSE. DEWETRON shall not be liable for any direct, indirect, special, incidental, or consequential damages, whether based on contract, tort, or any other legal theory, in connection with the furnishing of this document or the use of the information in this document.

Printing history

Refer to the page bottom for printing version.

Copyright © DEWETRON GmbH

This document contains information which is protected by copyright. All rights are reserved. Reproduction, adaptation, or translation without prior written permission is prohibited, except as allowed under the copyright laws.



INTRODUCTION

Notes

System setup

Key facts

- ▶ Portable all-in-one data acquisition system
- ▶ Rugged industrial design
- ▶ 13" TFT wide-screen touch display
- ▶ Up to 32 analog inputs
- ▶ Optional internal buffer battery for <5 minutes
- ▶ Local data storage or data transfer via Ethernet

System specifications

DEWE2-A4	
Data acquisition	4 slots for TRION acquisition modules
Standard power supply	150 W isolated power supply; external AC power supply included
<ul style="list-style-type: none"> – Rated input voltage – DW2-PS-PC-BUFFER (optional) – Power consumption w/o modules 	<ul style="list-style-type: none"> – 11...32 VDC (max. 10...36 VDC) – Internal UPS battery for <5 min. (dep. on system and configuration) – Max. 75 W
Operating temperature	0 °C to +50 °C, down to -20 °C with pre-warmed unit
Storage temperature	-20 °C to +70 °C
Humidity	10 % to 80 %, non condensing; 5 % to 95 % rel. humidity
Altitude ¹⁾	4000 m (13 123 ft.)
Sine vibration test²⁾; EN 60068-2-6	
Shape	Sine
Frequency range	10–150 Hz
Acceleration	20 m/s ²
Sweep rate	1 oct./min.
Duration test in 3 directions	20 cycles
Random vibration test²⁾; EN 60721-3-2; Class 2M3	
Shape	Random
Frequency range	10–200 Hz
Spectral acceleration density	3 m ² /s ³
Duration	30 minutes/direction
Shocktests²⁾; EN 60068-2-27	
Shape	Half-sine
Acceleration amplitude	30 g
Duration	11 ms
	3 bumps each direction, 6 directions in total
Dimensions (W x D x H) without feet	317 x 253 x 124 mm (12.5 x 10 x 4.9 in.)
Weight w/o TRION modules	Typ. 5.9 kg (13 lbs.)

1) Depending on installed TRION™ series modules. Refer to the TRION technical reference manual.

2) Tested with SSD

Tab. 1: System specifications DEWE2-A4

SYSTEM SETUP

Dimensions

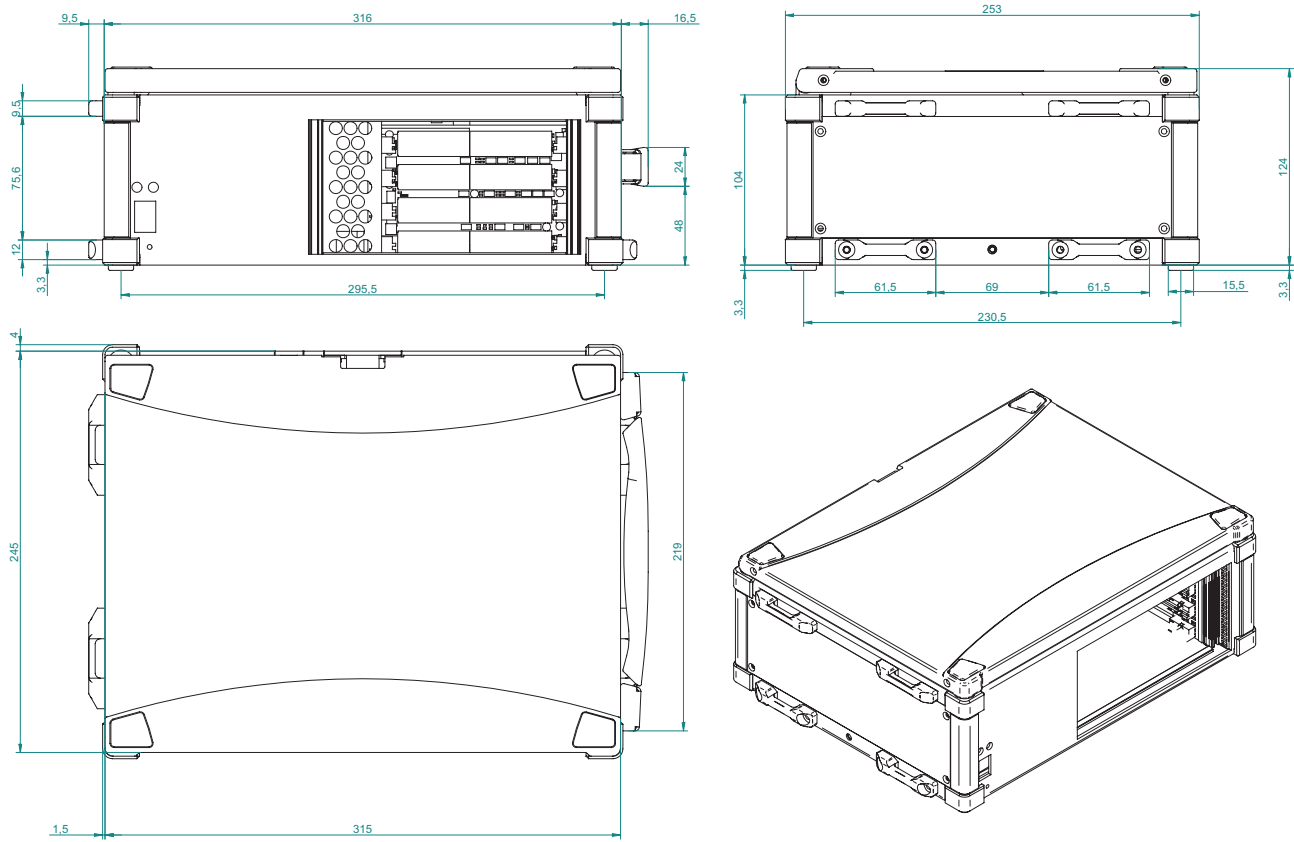

*) Dimensions in mm (1 inch = 25.4 mm)

Fig. 2: Dimensions DEWE2-A4

Connections and ports

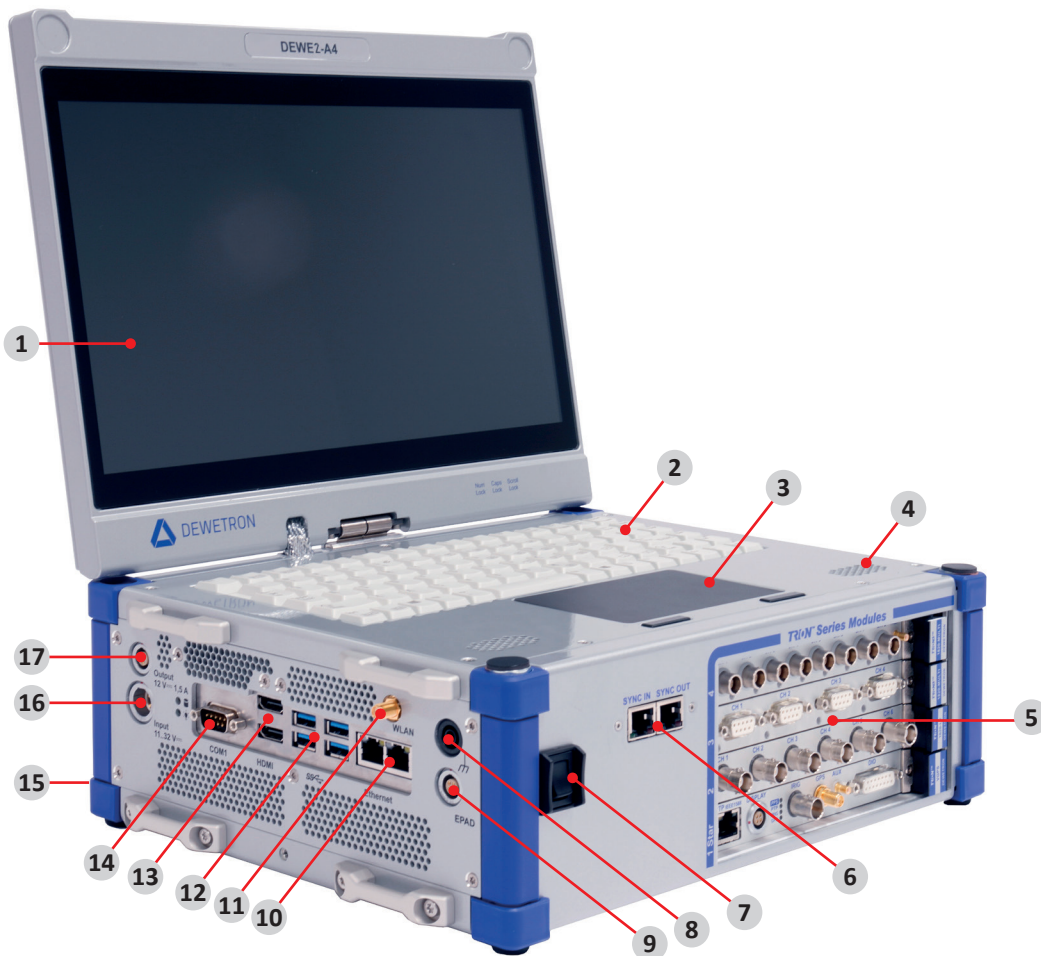

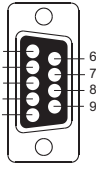



Fig. 3: Connections and ports DEWE2-A4

No.	Element	Description
1.	Display	13" TFT touchscreen with 1920 x 1080 px resolution
2.	Keyboard	Integrated 84-keys keyboard
3.	Touchpad	Integrated touchpad
4.	Speakers	Integrated speakers
5.	TRION series module slots	Slots for TRION series modules. For more information about the various modules refer to <i>TRION series modules overview on page 19</i> .
6.	TRION SYNC-BUS	The TRION SYNC-BUS allows an easy highspeed channel expansion with TRIONet front-ends or distributed high channel-count systems featuring OXYGEN with the OXY-OPT-NET software option.
7.	Power-on switch	The power-on switch is used to switch on the system.
8.	Chassis terminal	 For some kind of measurements, it is necessary to provide the system with an additional ground connection.

Tab. 2: Connections and ports DEWE2-A4

SYSTEM SETUP

No.	Element	Description										
9.	EPAD2 connector (LEMO) Lemo EGG.1B.304	 <p>Used connect DEWETRON EPAD modules to the system. Shield is connected on housing.</p> <p>Pin assignment:</p> <ol style="list-style-type: none"> 1. RS-485 A 2. RS-485 B 3. +12 V 4. GND <p>Mating connector</p> <ul style="list-style-type: none"> ▶ LEMO FGG.1B.304.CLAD52Z (for cable diameter 4.1 to 5.0 mm) ▶ LEMO FGG.1B.304.CLAD62Z (for cable diameter 5.1 to 6.0 mm) 										
10.	Ethernet LAN connector	The DEWE2-A4 system supports 10/100/1000 BaseT Ethernet with standard RJ45 connector.										
11.	WLAN antenna	The DEWE2-A4 supports 802.11 ac WLAN standards.										
12.	USB interface connectors	The USB 3.0 interface connectors meet standard USB pin assignments.										
13.	HDMI connector	The HDMI connector meets the standard HDMI pin assignment.										
14.	RS-232 interface connector (COM 1)	 <p>The RS-232 interface connector (male) is configured as standard RS-232 interface COM 1 and can be used for mouse or other peripheral units.</p> <p>Pin assignment:</p> <table border="0"> <tr> <td>1. DCD (Data Carrier Detector)</td> <td>6. DSR (Data Set Ready)</td> </tr> <tr> <td>2. RD (Received Data)</td> <td>7. RTS (Request To Send)</td> </tr> <tr> <td>3. TD (Transmitted Data)</td> <td>8. CTS (Clear To Send)</td> </tr> <tr> <td>4. DTR (Data Terminal Ready)</td> <td>9. RI (Ring Indicator)</td> </tr> <tr> <td>5. GND (Ground)</td> <td></td> </tr> </table>	1. DCD (Data Carrier Detector)	6. DSR (Data Set Ready)	2. RD (Received Data)	7. RTS (Request To Send)	3. TD (Transmitted Data)	8. CTS (Clear To Send)	4. DTR (Data Terminal Ready)	9. RI (Ring Indicator)	5. GND (Ground)	
1. DCD (Data Carrier Detector)	6. DSR (Data Set Ready)											
2. RD (Received Data)	7. RTS (Request To Send)											
3. TD (Transmitted Data)	8. CTS (Clear To Send)											
4. DTR (Data Terminal Ready)	9. RI (Ring Indicator)											
5. GND (Ground)												
15.	SSD drive bay	The DEWE2-A4 is equipped with a 256 GB SSD that contains the operating system and application software and serves as data storage.										
16.	Power supply input connector EGJ.2B.302	Input range 11...32 VDC (external AC/DC power supply included). For details see <i>Power supply on page 22</i> .										
17.	Power supply output for accessories (12 VDC) LEMO EGG.1B.302	 <p>Used to supply your accessories with 12 VDC. Fused with an 1.5 A self-recovering fuse.</p> <p>Mating connector:</p> <ul style="list-style-type: none"> ▶ LEMO FGG.1B.302.CLAD52Z (for cable diameter 4.1 to 5.0 mm) ▶ LEMO FGG.1B.302.CLAD62Z (for cable diameter 5.1 to 6.0 mm) 										
Option DW2-LAN-2		The DEWE2-A4 is equipped with two additional 1 GBit LAN interfaces connectors which replace the WLAN interface.										







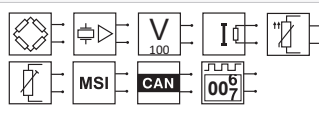
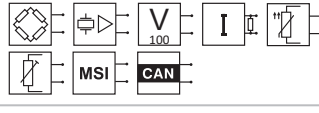

Tab. 2: Connections and ports DEWE2-A4

NOTICE

Information for systems with SSD drives: Wait for 40 seconds after big files were deleted. The HDD activity LED is lit to indicate that the SSD is deleting the file and TRIM/garbage collection is in progress. Wait until the process is finished before you start to write the next file.

TRION series modules overview

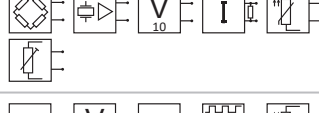
Analog modules

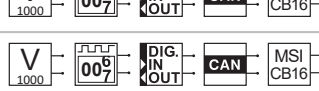
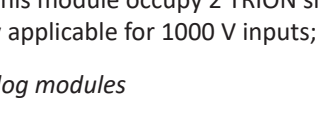

ANALOG modules		Channels	Sample rate per channel	Resolution	Isolation	Connector type
TRION-1820-MULTI		4	2 MS/s	24 bit >2 MS/s: 18 bit	yes	D-SUB
TRION-2402-MULTI		4 or 8	200 kS/s	24 bit	yes	D-SUB, LEMO 0B
TRION-1620-ACC		6	2 MS/s	24 bit >1 MS/s: 16 bit	yes	LEMO 1B, BNC
TRION-1620-LV		6	2 MS/s	24 bit >1 MS/s: 16 bit	yes	LEMO 1B, BNC
TRION-2402-V ¹⁾		4 or 8	200 kS/s	24 bit	yes	Safety banana
TRION-1810-HV ¹⁾		4 or 8	1 MS/s	18 bit	yes	Safety banana, CAT III 1000 V ²⁾
TRION-1603-LV		6	250 kS/s	16 bit	yes	BNC, LEMO 1B
TRION-2402-dSTG ¹⁾		6–8	200 kS/s	24 bit	no	LEMO 1B, LEMO 0B, D-SUB, RJ-45
TRION-2402-dACC		6–8	200 kS/s	24 bit	no	SMB, BNC
TRION-1802-dLV		16 or 32	200 kS/s 100 kS/s	18 bit 24 bit	no	D-SUB
TRION-1600-dLV		16 or 32	20 kS/s	16 bit	no	D-SUB

1) Some versions of this module occupy 2 TRION slots.

2) CAT III 1000 V only applicable for 1000 V inputs; SUB-600V has CAT II 600 V / CAT III 300 V

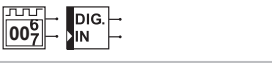

Tab. 3: TRION analog modules

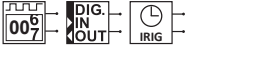
Digital modules

DIGITAL modules		Channels	Sample rate per channel	Resolution	Isolation	Features
TRION-CNT		6	800 kS/s	80 MHz	yes	6 channel advanced counter
TRION-DI-48		48	2 MS/s	500 nsec	yes	48 highspeed digital IN
TRION-BASE		-	2 MS/s	80 MHz	no	Basic IO card with simple IIRIG sync and 2 counter

Tab. 4: TRION digital modules

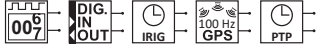
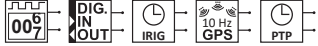
SYSTEM SETUP

DIGITAL modules		Channels	Sample rate per channel	Resolution	Isolation	Features
TRION-VGPS-V3		-	2 MS/s	0.01 km/h <10 cm	no	100 Hz GNSS receiver for automotive applications
TRION-TIMING-V3		-	2 MS/s	12.5 nsec	no	Applies precision absolute time to measured data
TRION-CAN		4	1 MBit	-	yes	D-SUB
TRION-ARINC	-	4 or 16	-	-	no	Decoding of ARINC 429 signals, export of decoded signals
TRION-MIL1533	-	1 or 4	-	-	no	Decoding of MIL-STD 1553 signals, export of decoded signals
TRION-EtherCAT-1-SLAVE		100	500 S/s	-	no	Measurement data output

Tab. 4: TRION digital modules

Power modules

POWER modules		Channels	Sample rate per channel	Resolution	Isolation	Connector type
TRION-1820-POWER		8 (4 U / 4 I)	2 MS/s	18 bit	yes	Safety banana, D-SUB

Tab. 5: TRION power modules

INFORMATION

The TRION-TIMING module has to be installed in the STAR-slot for TRION modules. For further information regarding the STAR-slot for TRION modules refer to the TRION series modules technical reference manual.

INFORMATION

Some digital modules (e.g. TRION-M1553) require additional -12 VDC voltage which is not supported with DC powered DEWE2 instruments by default. Ask your local dealer or factory for more information.

Installing a TRION module

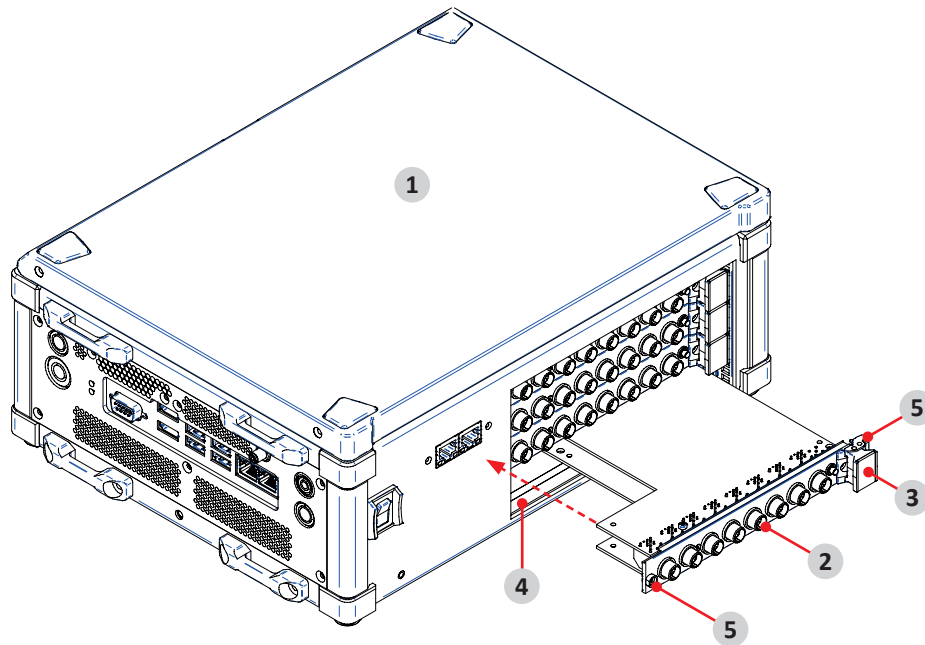

Fig. 4: Installing a TRION module

- | | |
|----------------------------|--------------------|
| 1. DEWE2 chassis | 4. Module guides |
| 2. TRION series module | 5. Mounting screws |
| 3. Injector/ejector module | |

In order to install a TRION module into a chassis proceed as follows:

1. ⚠ Take proper ESD precautions to avoid any damage to the unit.
2. Power off and unplug all connected cables including sensors from the DEWE2 chassis and TRION series modules.
3. Identify a supported TRION peripheral slot.
Some modules require a TRION STAR-slot.
4. Remove the filler panel of an unused TRION peripheral or STAR-slot.
5. Place the module edges of the TRION module into the module guide at the top and bottom of the chassis.
6. Insert the TRION module to the rear of the chassis until a resistance appears.
7. Pull up on the injector/ejector handle to latch the device.
8. Secure the installed TRION front panel to the chassis by using the mounting screws.

The TRION module is now installed into a DEWE2 chassis.

NOTICE

Unused TRION slots must always be covered. Make sure to reinstall the filler panels to unused TRION slots to guarantee proper cooling of the installed modules.

The warranty is void if the modules overheat due to missing filler panels.

SYSTEM SETUP

Power supply

The DEWE2-A4 is delivered with a standard external AC/DC power supply.

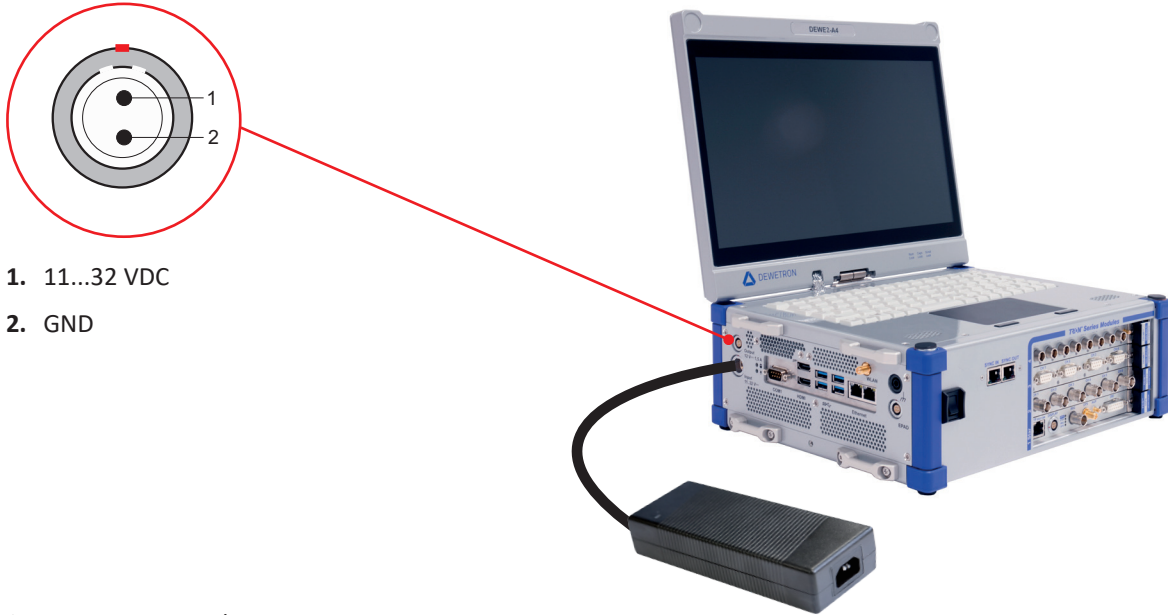

1. 11...32 VDC
2. GND

Fig. 5: Power supply

Internal DC power supply

150 W DC power supply	
Input	
– Rated input voltage	11...32 VDC (max. 10...36 VDC)
– Input frequency	DC
– Power	150 W
– Connector	2-pin male LEMO EGJ.2B.302

Tab. 6: Specifications internal 150 W DC power supply

External AC/DC power supply

250 W AC/DC power supply	
Input	
– Rated input voltage	100...240 VAC (max. 90 ... 264 VAC)
– Input frequency	50...60 Hz
– Current	max. 3 A
Output	
– Voltage	24 VDC
– Current	10.42 A (max. load)
– Output power	max. 250 W

Tab. 7: Specifications external 250 W AC/DC power supply

DW2-PS-DC-BUFFER (option)

The DEWE2-x4 series system is equipped with an internal buffer battery to bridge supply voltage drops of up to 5 minutes. This option is especially useful for in-vehicle testing to bridge the cars battery voltage drop when starting the engine but also for many other applications where short power breakdowns must not interrupt the measurement, e.g. power monitoring.

NOTICE

Battery exchange has to be done by qualified persons only.

System recovery

For more information regarding a total recovery refer to the corresponding total recovery technical reference manual shipped with your DEWE2 system.

Synchronization

The TRION-SYNC-BUS (SYNC I/O, SYNC OUT) is used to synchronize two or more DEWE2 systems with up to 100 m distance between each node. The TRION-SYNC-BUS consists of two RJ-45 sockets. One socket being a synchronization OUT, whilst the other one could either be used as synchronization IN or OUT.

Depending on the usage of the SYNC I/O (input or output) the LED indicates if the system clock is available or received correctly from another system. The green LED indicates that the acquisition is running. If the acquisition stops the LED will be off.

LED indication	SYNC OUT	SYNC I/O
RED (stable)	Clock detected	Clock detected / receiving clock
Green (stable)	Acquisition running	Acquisition running

Tab. 8: LED indication

Channel expansion with TRIONet

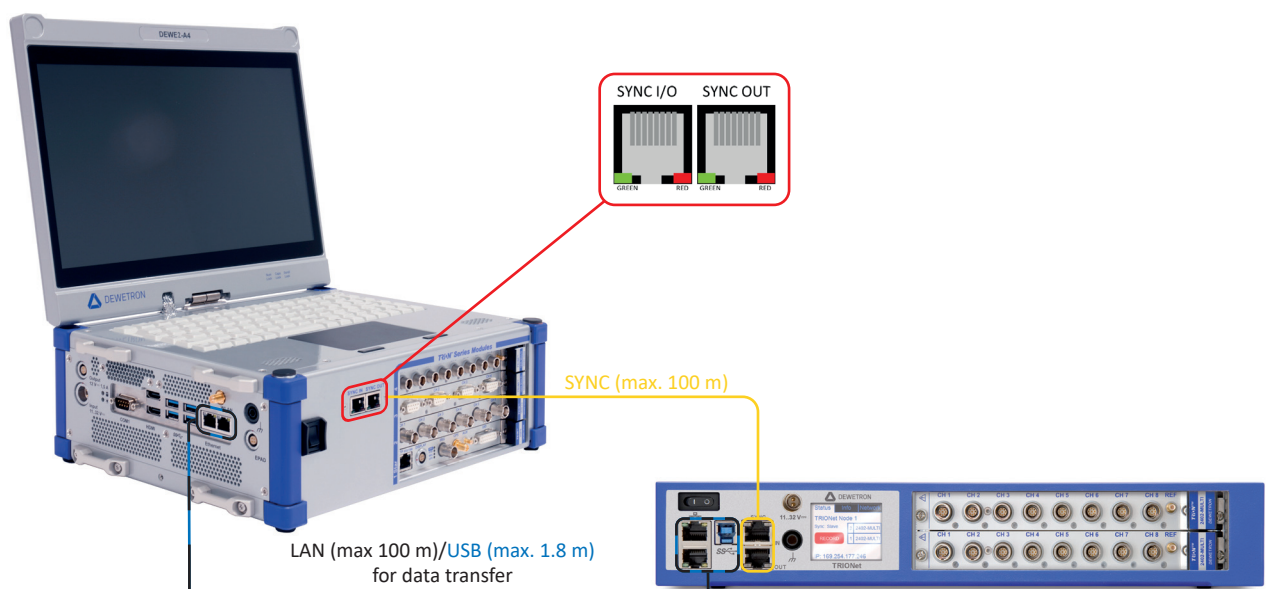

Fig. 6: Channel expansion with TRIONet

SYSTEM SETUP

Network with multiple systems



Fig. 7: Network with multiple systems

Absolute time synchronization

With this option, the DEWE2-A4 can operate synchronized with other measurement devices with an absolute time reference.

PTP sync / IRIG sync

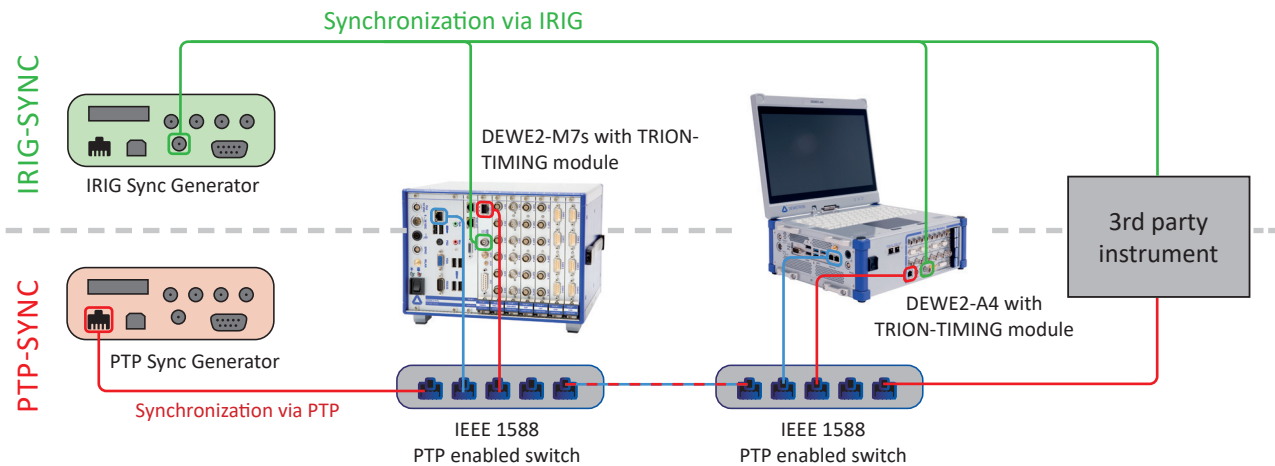

Fig. 8: PTP sync / IRIG sync

GPS sync

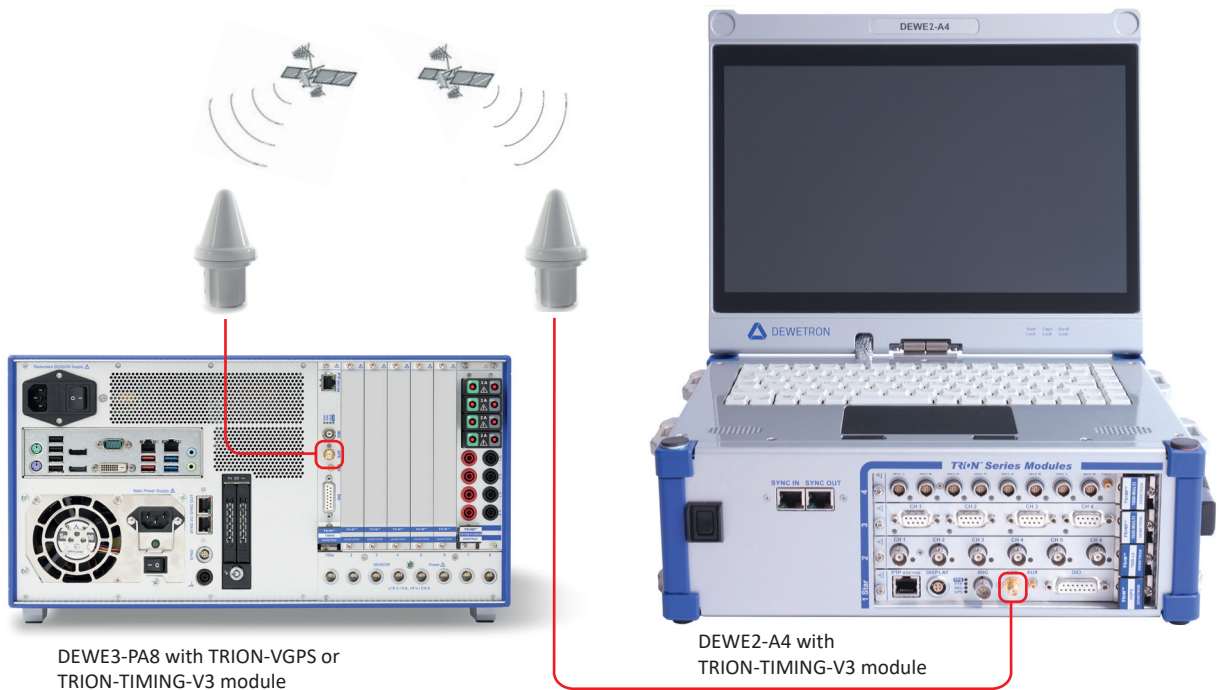

Fig. 9: GPS sync

SYSTEM SETUP

Notes

Maintenance and service

The information in this section is designed for use by qualified service personal.

Service interval

Clean dust from the chassis exterior/interior and exchange filter foam based on the operating environment.

Cleaning

- ▶ Clean surface of the chassis with dry lint-free cloth.
- ▶ Use a dry velocity stream of air to clean the chassis interior.

Do not use harsh chemical cleaning agents.

NOTICE



Many components within the chassis are sensitive to static discharge damage. Always wear a ground wrist strap and service the unit only in static-free environment.

WARNING



Risk of injury

Disconnect all cables before servicing the unit.



Updates

Windows and antivirus/security software

Before installing Windows software updates consult with DEWETRON for compatibility guidance. Also keep in mind that the use of any antivirus or other security software may slow down your system and may cause data loss.

Software updates

NOTICE

The system BIOS is protected by password. Any change in the BIOS may cause a system crash. When the system is booting, do not press ESC-button on keyboard. This may clear the BIOS settings and cause system faults.

Any change in the file structure as deleting or adding files or directories might cause a system crash.

Before installing software updates contact DEWETRON or your local distributor. Use only software packages which are released by DEWETRON. Further information is also available in the Internet (<http://www.dewetron.com>).

After power off the system wait at least 10 seconds before switching the system on again. Otherwise the system may not boot correct. This prolongs also the life of all system components.

MAINTENANCE AND SERVICE

Training

DEWETRON offers training at various offices around the world several times each year. DEWETRON headquarters in Austria have a very large and professional conference and seminar center, where training classes are conducted on a regular basis starting with sensors and signal conditioning, A/D technology and software operation.

Dewetron Inc. in the USA also has a dedicated training facility connected to its headquarters, located in Rhode Island.

For more information about training services visit <https://www.dewetron.com/academy>.

Calibration

Every instrument needs to be calibrated at regular intervals. The standard norm across nearly every industry is annual calibration. Before your DEWETRON data acquisition system is delivered, it is calibrated at our DEWETRON headquarter. Each of this system is delivered with a certificate of compliance with our published specifications. Detailed calibration reports from our calibration system are available for purchase with each order. We retain them for at least one year, so calibration reports can be purchased for up to one year after your system was delivered.

Support

DEWETRON has a team of people ready to assist you if you have any questions or any technical difficulties regarding the system. For any support contact your local distributor first or DEWETRON directly.

For Asia and Europe contact:

DEWETRON GmbH
Parkring 4
8074 Grambach
AUSTRIA

Tel.: +43 316 3070
Fax: +43 316 3070-90
E-Mail: support@dewetron.com
Web: <http://www.dewetron.com>

The telephone hotline is available
Monday to Friday between
08:00 and 17:00 CET (GMT +1:00).

For the Americas contact:

DEWETRON Inc. (HQ USA)
2850 South County Trail, Unit 1
East Greenwich, RI 02818
USA

Tel.: +1 401 284 3750
Toll-free: +1 866 598 3393
Fax: +1 401 284 3750
Email: support@dewetron.com
Web: <http://www.dewetron.com>

The telephone hotline is available
Monday to Friday between
08:00 and 16:30 EST

Service and repairs

We are very sorry that your DEWETRON system is not operating properly. Our team is here to ensure that your DEWETRON product is returned to peak performance as quickly as possible.

Help us to provide you with the best support by following the RMA policy.

Some problems can be solved remotely by our support team. To facilitate a quicker resolution to the problem and save unnecessary shipping costs, we ask you to first have your problem investigated by our technical support before sending your product. Contact details for our support can be found on our website. Describe the error accurately and with as much detail as possible. This helps expedite the repair process.

If a repair is necessary, complete our online [RMA form](#). You will then receive an RMA (Return Material Authorization) number and detailed instructions that identify where to ship the damaged product.

Products arriving at our repair department without RMA require follow-up calls and investigation, which lead to a longer turnaround. Only the team of DEWETRON is allowed to perform any kinds of repairs to your system to assure a safe and proper operation in future.

MAINTENANCE AND SERVICE

INFORMATION

Only the team of DEWETRON is allowed to perform any kinds of repairs to your system to assure a safe and proper operation in future. For information regarding service and repairs contact your local distributor first or DEWETRON directly.

INFORMATION

Any spare parts (screws, backplanes, cables etc.) must be obtained from DEWETRON only.

▼

MAINTENANCE AND SERVICE

Notes

CERTIFICATE OF CONFORMITY

Certificate of conformity



Manufacturer

DEWETRON GmbH

Address

Parkring 4
8074 Grambach, Austria
Tel.: +43 316 3070-0
Fax: +43 316 3070-90
Email: sales@dewetron.com
<http://www.dewetron.com>

Name of product

DEWE2-A4

Kind of product

Data acquisition instrument

The product meets the regulations of the following EC-directives:

2006/95/EC

„Directive on the approximation of the laws of the Member States relating to electrical equipment designed for use within certain voltage limits.“

2004/108/EC

„Directive on the approximation of the laws of the Member States relating to electromagnetic compatibility amended by the directives 89/336/EWG.“

The accordance is proved by the observance of the following standards:

L V E M C	Safety	IEC 61010-1:2011 300 V CATII, Pol. Deg. 2	
	Emissions	EN 61000-6-4	EN 55011 Class B
	Immunity	EN 61000-6-2	Group standard

Graz, May 23, 2013

Place / Date of the CE-marking

Ing. Thomas Propst / Manager Total Quality

▼

CERTIFICATE OF CONFORMITY

Notes

Glossary

ESD

Electrostatic discharge

GND

Ground

IEEE

Institute of Electrical and Electronics Engineers

IRIG

Inter range instrumentation group

IT/MIS

Management information system

PTP

Precision time protocol

SIL

Safety integrity level

STAR-slot

TRION-slot for clock distribution when using TIMING modules

SSD

Solid state drive

WEEE

Waste of electrical and electronic equipment (European Community Directive 2002/96/EC)

▼
GLOSSARY
