



DEWETRON

---

# DEWE-3300

## TECHNICAL REFERENCE MANUAL

---

### WELCOME TO THE WORLD OF DEWETRON!

Congratulations on your new device! It will supply you with accurate, complete and reproducible measurement results for your decision making.

Look forward to the easy handling and the flexible and modular use of your DEWETRON product and draw upon more than 25 years of DEWETRON expertise in measurement engineering.

---

ISO9001



CUSTOMIZED



MODULAR



COMPETENT



COMMITTED



APPROVED

Copyright © DEWETRON GmbH

This document contains information which is protected by copyright. All rights are reserved. Reproduction, adaptation, or translation without prior written permission is prohibited, except as allowed under the copyright laws.

All trademarks and registered trademarks are acknowledged to be the property of their owners.  
DEWESoft™ is a trademark of Dewesoft d.o.o

## **Thank you!**

Thank you very much for your investment in DEWETRON's unique data acquisition systems. These are top-quality instruments which are designed to provide you years of reliable service. This guide has been prepared to help you get the most from your investment, starting from the day you take it out of the box, and extending for years into the future.

This guide includes important startup notes, as well as safety notes and information about keeping your DEWETRON system in good working condition over time.

We strongly suggest that you read this entire manual, especially the safety and care sections, as well as to avoid damaging your DEWETRON system.

## **What is the DEWE-3300?**

This product is used for measuring of different physical and/or electrical sizes (depending on model or configuration). The connection is depending on model or configuration and takes place via safety banana plugs, BNC connectors ( $\pm 50V$  max.), D-SUB connectors ( $\pm 50V$  max.), thermocouple connectors ( $\pm 50V$  max.), BINDER® connectors ( $\pm 50V$  max.), SMB connectors ( $\pm 50V$  max.),  $\mu$ dot connectors ( $\pm 50V$  max.), LEMO® connectors or RJ-45 connectors.

▼  

---

**PREFACE**

**Notes**

## **Content**

<b>General Information, Safety Instructions</b>	<b>7</b>
Training .....	7
Calibration .....	7
Support .....	7
Service/repairs .....	7
Warranty Information .....	8
Printing History .....	8
Safety conventions .....	9
General safety and hazard warnings for all DEWETRON systems .....	10
Maintenance .....	13
Windows updates and antivirus/security software .....	14
Problematic network stacks .....	14
Environmental Considerations .....	14
<b>Main System</b>	<b>15</b>
DEWE-3300 - All-in-one standard instrument .....	15
System specifications .....	15
Base models .....	16
Dimensions .....	16
DEWE-330x at a glance .....	17
Possible configurations and panel options .....	22
Power supply .....	23
<b>A/D Conversion</b>	<b>A1</b>
<b>Internal Wiring</b>	<b>B1</b>
<b>CE-Certificate of conformity</b>	<b>C1</b>

▼

---

# TABLE OF CONTENT

Notes

## Training

DEWETRON offers training at various offices around the world several times each year. DEWETRON headquarters in Austria have a very large and professional conference and seminar center, where training classes are conducted on a regular basis starting with sensors and signal conditioning, A/D technology and software operation. For more information about training services, please visit:

<http://www.dewetron.com/en/services/dewetron-academy.php>

Dewetron Inc. in the USA also has a dedicated training facility connected to its headquarters, located in Rhode Island. For more information about training services in the US, please visit:

<http://www.dewamerica.com/support/trainingclasses>

## Calibration

Every instrument needs to be calibrated at regular intervals. The standard norm across nearly every industry is annual calibration. Before your DEWETRON data acquisition system is delivered, it is calibrated at our DEWETRON headquarter. Each of this system is delivered with a certificate of compliance with our published specifications. Detailed calibration reports from our calibration system are available for purchase with each order. We retain them for at least one year, so calibration reports can be purchased for up to one year after your system was delivered.

## Support

DEWETRON has a team of people ready to assist you if you have any questions or any technical difficulties regarding the system. For any support please contact your local distributor first or DEWETRON directly.

For Asia and Europe, please contact:

DEWETRON GmbH  
Parkring 4  
8074 Grambach  
AUSTRIA  
Tel.: +43 316 3070  
Fax: +43 316 307090  
Email: [support@dewetron.com](mailto:support@dewetron.com)  
Web: <http://www.dewetron.com>

The telephone hotline is available  
Monday to Friday between  
08:00 and 17:00 CET (GMT +1:00)

For the Americas, please contact:

DEWETRON, Inc.  
2850 South County Trail, Unit 1  
East Greenwich, RI 02818  
U.S.A.  
Tel.: +1 401 284 3750  
Toll-free: +1 866 598 3393  
Fax: +1 401 284 3755  
Email: [support@dewamerica.com](mailto:support@dewamerica.com)  
Web: <http://www.dewamerica.com>

The telephone hotline is available  
Monday to Friday between  
08:00 and 4:30 EST

## Service/repairs

Only the team of DEWETRON is allowed to perform any kinds of repairs to your system to assure a safe and proper operation in future. For information regarding service and repairs please contact your local distributor first or DEWETRON directly.



Any spare parts (screws, backplanes, cables,...) must be obtained from DEWETRON only.

# ▼ NOTICE

---

The information contained in this document is subject to change without notice.

DEWETRON GmbH (DEWETRON) shall not be liable for any errors contained in this document. DEWETRON MAKES NO WARRANTIES OF ANY KIND WITH REGARD TO THIS DOCUMENT, WHETHER EXPRESS OR IMPLIED. DEWETRON SPECIFICALLY DISCLAIMS THE IMPLIED WARRANTIES OF MERCHANTABILITY AND FITNESS FOR A PARTICULAR PURPOSE. DEWETRON shall not be liable for any direct, indirect, special, incidental, or consequential damages, whether based on contract, tort, or any other legal theory, in connection with the furnishing of this document or the use of the information in this document.

## **Warranty Information**

A copy of the specific warranty terms applicable to your DEWETRON product and replacement parts can be obtained from your local sales and service office.

## **Restricted Rights Legend**

Use austrian law for duplication or disclosure.

DEWETRON GmbH  
Parkring 4  
A-8074 Grambach / Austria

TRION™ is a trademark of DEWETRON GmbH.

Any other trademarks and registered trademarks are acknowledged to be the property of their owners.

## **Printing History**

Please refer to the page bottom for printing version.

Copyright © DEWETRON GmbH.

This document contains information which is protected by copyright. All rights are reserved. Reproduction, adaptation, or translation without prior written permission is prohibited, except as allowed under the copyright laws.

## Safety conventions



*Observe precautions for handling electrostatic sensitive devices!*



*This icon denotes a caution, which advises you of precautions to take to avoid injury, data loss, or a system crash. When this symbol is marked on the product, refer to the technical reference manual.*



*Indicates hazardous voltages.*



*Indicates the chassis terminal*

**WARNING** *Calls attention to a procedure, practice, or condition that could cause bodily injury or death.*

**CAUTION** *Calls attention to a procedure, practice, or condition that could possibly cause damage to equipment or permanent loss of data.*

### WARNINGS

*The following general safety precautions must be observed during all phases of operation, service, and repair of this product. Failure to comply with these precautions or with specific warnings elsewhere in this manual violates safety standards of design, manufacture, and intended use of the product. DEWETRON GmbH assumes no liability for the customer's failure to comply with these requirements.*

---

# SAFETY INSTRUCTIONS

**Your safety is our primary concern! Please be safe!**



## **General safety and hazard warnings for all DEWETRON systems**

- > Use this system under the terms of the specifications only to avoid any possible danger. If the unit is used in a manner not specified by the manufacturer the protection can be impaired!
- > This product is intended for use in industrial locations. As a result, this product may cause interference if used in residential areas. Such use must be avoided unless the user takes special measures to reduce electromagnetic emissions to prevent interferences to the reception of radio and television broadcasts.
- > Maintenance will be executed by qualified staff only.
- > During the use of the system, it might be possible to access another parts of a more comprehensive system. Please read and follow the safety instructions provided in the manuals of all other components regarding warning and security advices for using the system.
- > With this product, only use the power cable delivered or defined for the host country.
- > DO NOT connect or disconnect sensors, probes or test leads, as these parts are connected to a voltage supply unit.
- > The system is grounded via a protective conductor in the power supply cord. To avoid electric shocks, the protective conductor has to be connected with the ground of the power network. Before connecting the input or output connectors of the system, make sure that there is a proper grounding to guarantee potential free usage. For countries, in which there is no proper grounding, please refer to your local legally safety regulations for safety use.

DC systems: Every DC system has a grounding connected to the chassis (yellow/green safety banana plug).

- > Please note the characteristics and indicators on the system to avoid fire or electric shocks. Before connecting the system, please carefully read the corresponding specifications in the product manual.
- > The inputs are not, unless otherwise noted (CATx identification), for connecting to the main circuits of category II, III and IV. The measurement category can be adjusted depending on module configuration.
- > The power cord separates the system from the power supply. Do not block the power cord, since it has to be accessible for the users.
- > Supply overvoltage category is II.
- > DO NOT use the system if equipment covers or shields are removed.
- > If you assume the system is damaged, get it examined by authorised personnel only.
- > Any use in wet rooms, outdoors or in adverse environmental condition is not allowed!  
Adverse environmental conditions are:
  - > Moisture or high humidity
  - > Dust, flammable gases, fumes or dissolver
  - > Thunderstorm or thunderstorm conditions (except assembly PNA)
  - > Electrostatic fields, et cetera.
- > Any direct voltage output is protected with a fuse against short cut and reverse-polarity, but is NOT galvanically isolated (except it is explicit marked on the system).
- > The system must be connected and operated to an earthed wall socket at the AC mains power supply only (except for DC systems).
- > Any other use than described above may damage your system and is attended with dangers like shortcut, fire or electric shocks.

---

# SAFETY INSTRUCTIONS

- > The whole system must not be changed, rebuilt or opened (except for changing TRION™ modules).
- > If you assume a more riskless use is not provided anymore, the system has to be rendered inoperative and should be protected against inadvertent operation. It is assumed that a more riskless operation is not possible anymore, if
  - > the system is damaged obviously or causes strange noises.
  - > the system does not work anymore.
  - > the system has been exposed to long storage in adverse environmental.
  - > the system has been exposed to heavy shipment strain.
- > DO NOT touch any exposed connectors or components if they are live wired. The use of metal bare wires is not allowed. There is a risk of short cut and fire hazard!
- > Warranty void if damages caused by disregarding this manual. For consequential damages NO liability will be assumed!
- > Warranty void if damages to property or persons caused by improper use or disregarding the safety instructions.
- > Unauthorized changing or rebuilding the system is prohibited due to safety and permission reasons (CE). Exception: changing TRION™ modules.
- > The assembly of the system is equivalent to protection class I. For power supply, only the correct power socket of the public power supply must be used, except the system is DC powered.
- > Be careful with voltages  $>25 V_{AC}$  or  $>35 V_{DC}$ ! These voltages are already high enough in order to get a perilous electric shock by touching the wiring.
- > The maximum input voltage for input modules are  $60 V_{DC}$  and  $42.4 V_{PEAK}$  except for DAQP-LV module. The maximum input voltage for DAQP-LV module is  $\pm 50 V_{DC}$  or  $\pm 50 V_{PEAK}$ . No measuring category according to IEC 61010-2-030:2010. The DAQP-LV must not be connected to mains circuit with overvoltage category II,III,IV.

Measurement category II is applicable to test and measuring circuits connected directly to utilization points of the low voltage mains installation. This part of installation is expected to have a minimum of 3 levels of overcurrent protective devices between the transformer and the connecting points of the measuring circuit.

Measurement category III is applicable to test and measuring circuits connected to the distribution part of the buildings low voltage mains installation. This part of the installation is expected to have a minimum of two levels of overcurrent protective devices between the transformer and possible connecting points.

Measurement category IV is applicable to test and measuring circuits connected at the source of the buildings low voltage mains installation. This part of the installation is expected to have a minimum of one level of overcurrent protective devices between the transformer and connecting points of the measuring circuit.

DC model, connect power supply only to mains supply OVC II.

AC model, connect power supply only to mains supply OVC II.

- > The product heats during operation. Make sure there is adequate ventilation. Ventilation slots must not be covered!
- > Only fuses of the specified type and nominal current may be used. The use of patched fuses is prohibited.
- > Prevent using metal bare wires! Risk of short cut and fire hazard!
- > DO NOT use the system before, during or shortly after a thunderstorm (risk of lightning and high energy overvoltage). An advanced range of application under certain conditions is allowed with therefore designed products only. For details please refer to the specifications.
- > Make sure that your hands, shoes, clothes, the floor, the system or measuring leads, integrated circuits and so on, are dry.

# SAFETY INSTRUCTIONS

- > DO NOT use the system in rooms with flammable gases, fumes or dust or in adverse environmental conditions.
- > Avoid operation in the immediate vicinity of:
  - > high magnetic or electromagnetic fields
  - > transmitting antennas or high-frequency generatorsFor exact values please refer to enclosed specifications.
- > Use measurement leads or measurement accessories aligned to the specification of the system only. Fire hazard in case of overload!
- > Do not switch on the system after transporting it from a cold into a warm room and vice versa. The thereby created condensation may damage your system. Acclimatise the system unpowered to room temperature.
- > Do not disassemble the system! There is a high risk of getting a perilous electric shock. Capacitors still might be charged, even if the system has been removed from the power supply.
  
- > Direct exposure of any DEWETRON product to strong sunlight or other heat radiation shall be prevented, as this could excessively heat up the product and lead to permanent damage of the product.
- > The electrical installations and equipments in industrial facilities must be observed by the security regulations and insurance institutions.
- > The use of the measuring system in schools and other training facilities must be observed by skilled personnel.
- > The measuring systems are not designed for use on humans and animals.
- > Please contact a professional if you have doubts about the method of operation, safety or the connection of the system.
- > Please be careful with the product. Shocks, hits and dropping it from already lower level may damage your system. For exact values please refer to enclosed specifications.
- > Please also consider the detailed technical reference manual as well as the security advices of the connected systems.

This product has left the factory in safety-related flawless and proper condition.

In order to maintain this condition and guarantee safety use, the user has to consider the security advices and warnings in this manual.

EN 61326-3-1:2008

IEC 61326-1 applies to this part of IEC 61326 but is limited to systems and equipment for industrial applications intended to perform safety functions as defined in IEC 61508 with SIL 1-3.

The electromagnetic environments encompassed by this product family standard are industrial, both indoor and outdoor, as described for industrial locations in IEC 61000-6-2 or defined in 3.7 of IEC 61326-1. Equipment and systems intended for use in other electromagnetic environments, for example, in the process industry or in environments with potentially explosive atmospheres, are excluded from the scope of this product family standard, IEC 61326-3-1.

Devices and systems according to IEC 61508 or IEC 61511 which are considered as “operationally well-validated”, are excluded from the scope of IEC 61326-3-1.

Fire-alarm and safety-alarm systems, intended for protection of buildings, are excluded from the scope of IEC 61326-3-1.

## Maintenance

The information in this section is designed for use by qualified service personal.

### Service interval:

Clean dust from the chassis exterior/interior and exchange filter foam based on the operating environment.

### Cleaning:

Clean surface of the chassis with dry lintfree cloth.

Use a dry velocity stream of air to clean the chassis interior.



- > Disconnect all cables before servicing the unit!
- > Many components within the chassis are sensitive to static discharge damage. Always wear a ground wrist strap and service the unit only in static-free environment.
- > Do not use harsh chemical cleaning agents!

# GENERAL INFORMATION

## CAUTION

- > The system BIOS is protected by password. Any change in the BIOS may cause a system crash. When the system is booting, do not press ESC-button on keyboard. This may clear the BIOS settings and cause system faults.
- > Any change in the file structure as deleting or adding files or directories might cause a system crash.
- > Before installing software updates contact DEWETRON or your local distributor. Use only software packages which are released by DEWETRON. Further informations are also available in the internet (<http://www.dewetron.com>).
- > After power off the system wait at least 10 seconds before switching the system on again. Otherwise the system may not boot correct. This prolongs also the life of all system components.

## Windows updates and antivirus/security software

Before installing Windows software updates consult with DEWETRON for compatibility guidance. Please also keep in mind that the use of any antivirus or other security software may slow down your system and may cause data loss.

## Problematic network stacks

Often intrusive IT software or network processes can interfere with the primary function of the DEWETRON system: to record data. Therefore we recommend strongly against the installation of IT/MIS software and running their processes on any DEWETRON data acquisition system, and cannot guarantee the performance of our systems if they are so configured.



## Environmental Considerations

Information about the environmental impact of the product.

## Product End-of-Life Handling

Observe the following guidelines when recycling a DEWETRON system:

## System and Components Recycling

Production of these components required the extraction and use of natural resources. The substances contained in the system could be harmful to your health and to the environment if the system is improperly handled at it's end of life! Please recycle this product in an appropriate way to avoid an unnecessary pollution of the environment and to keep natural resources.

This symbol indicates that this system complies with the European Union's requirements according to Directive 2002/96/EC on waste electrical and electronic equipment (WEEE). Please find further information about recycling on the DEWETRON website [www.dewetron.com](http://www.dewetron.com)

## Restriction of Hazardous Substances

This product has been classified as Monitoring and Control equipment, and is outside the scope of the 2011/65/EU RoHS Directive. This product is known to contain lead.

## DEWE-3300 - All-in-one standard instrument

- > Portable data acquisition system
- > Up to 16 channels with isolation  
(in conjunction with DAQP/HSI/PAD series modules)
- > Up to 32 channels with differential inputs  
(in conjunction with MDAQ series modules)



## System specifications

DEWE-330x													
DAQP / HSI / PAD amplifier slots	16 (in conjunction with DEWE-3300 model)												
MDAQ amplifier input channels	up to 32 (in conjunction with DEWE-3301 model)												
Standard power supply	100 to 240 V <sub>AC</sub> (max. 90 to 264 V <sub>AC</sub> ) 300 W AC power supply												
Rated input voltage													
Power supply option 3300-PS-DC-200	11 to 27 V <sub>DC</sub> (max. 9 to 30 V <sub>DC</sub> ) ATX power supply, external AC power supply included (250 W)												
Operating temperature	0 °C to +50 °C												
Storage temperature	-20 °C to +70 °C												
Humidity (operating)	10 % to 80 %, non condensing 5 % to 95 % rel. humidity												
Vibration test* EN 60068-2-6	<table border="0"> <tr> <td>Shape</td> <td>Sine</td> </tr> <tr> <td>Frequency range</td> <td>10 - 150 Hz</td> </tr> <tr> <td>Acceleration</td> <td>2 g</td> </tr> <tr> <td>Sweep rate</td> <td>1 oct./min.</td> </tr> <tr> <td>Duration</td> <td>20 Cycles</td> </tr> <tr> <td colspan="2">Test in 3 directions</td> </tr> </table>	Shape	Sine	Frequency range	10 - 150 Hz	Acceleration	2 g	Sweep rate	1 oct./min.	Duration	20 Cycles	Test in 3 directions	
Shape	Sine												
Frequency range	10 - 150 Hz												
Acceleration	2 g												
Sweep rate	1 oct./min.												
Duration	20 Cycles												
Test in 3 directions													
Vibration test* EN 60721-3-2 Class 2M2	<table border="0"> <tr> <td>Shape</td> <td>Random</td> </tr> <tr> <td>Frequency range</td> <td>10 - 200 Hz</td> </tr> <tr> <td>Power spectral density</td> <td>1 m/s<sup>2</sup> / Hz from 10 – 200 Hz</td> </tr> <tr> <td>Duration</td> <td>30 Minutes per axis</td> </tr> </table>	Shape	Random	Frequency range	10 - 200 Hz	Power spectral density	1 m/s <sup>2</sup> / Hz from 10 – 200 Hz	Duration	30 Minutes per axis				
Shape	Random												
Frequency range	10 - 200 Hz												
Power spectral density	1 m/s <sup>2</sup> / Hz from 10 – 200 Hz												
Duration	30 Minutes per axis												
Shocktests* EN 60068-2-27	<table border="0"> <tr> <td>Shape</td> <td>Half-sine</td> </tr> <tr> <td>Acceleration amplitude</td> <td>15 g</td> </tr> <tr> <td>Duration</td> <td>11 ms</td> </tr> <tr> <td colspan="2">Test in 3 axis, 3 shocks in each axis and direction</td> </tr> </table>	Shape	Half-sine	Acceleration amplitude	15 g	Duration	11 ms	Test in 3 axis, 3 shocks in each axis and direction					
Shape	Half-sine												
Acceleration amplitude	15 g												
Duration	11 ms												
Test in 3 axis, 3 shocks in each axis and direction													
Dimensions (W x H x D)	approx. 462 x 320 x 135 mm (18.2 x 12.6 x 5.3 in.)												
Weight	typ. 8.2 kg (18 lbs), depending on configuration												

\*) Tested with SSD disc

# MAIN SYSTEM

## Base models

**DEWE-3300**



- > 16 Slots for DAQP/HSI/PAD modules
- > Digital I/O, counter and EPAD connector on top

**DEWE-3301**



- > up to 32 channels with MDAQ series modules
- > Digital I/O, Counter, EPAD connector on side panel

## Dimensions

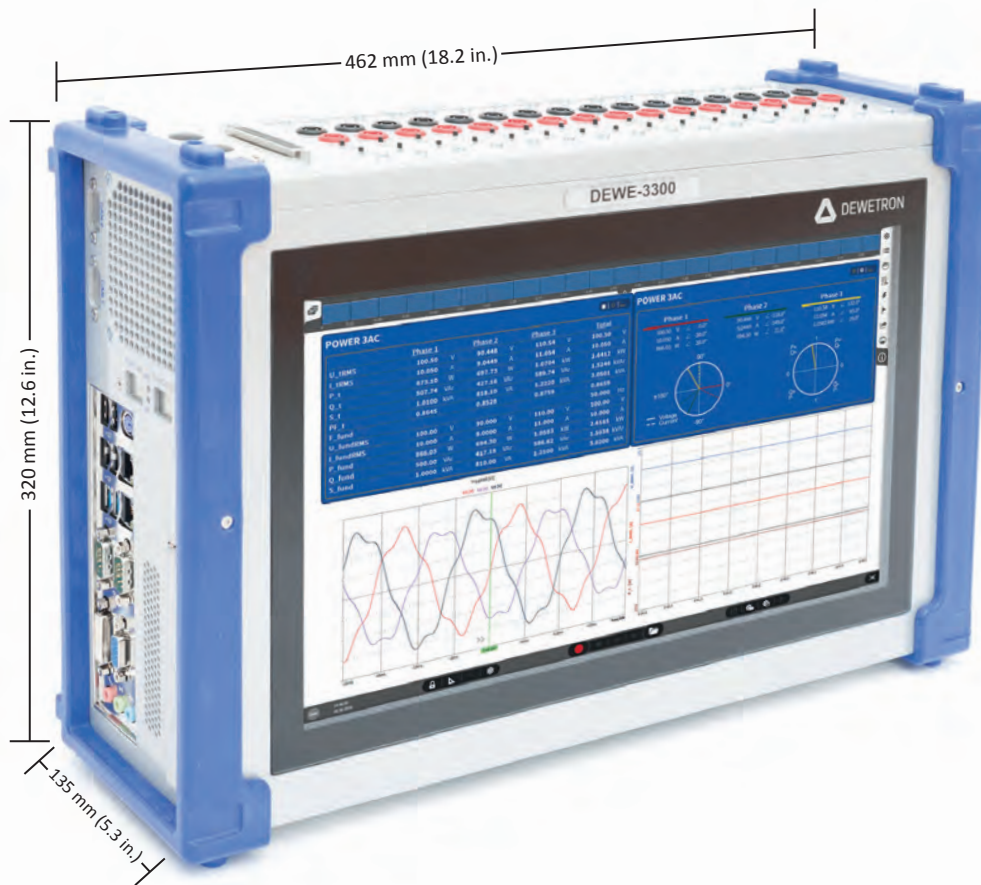

## DEWE-330x at a glance

Typical DEWE-3300 front view

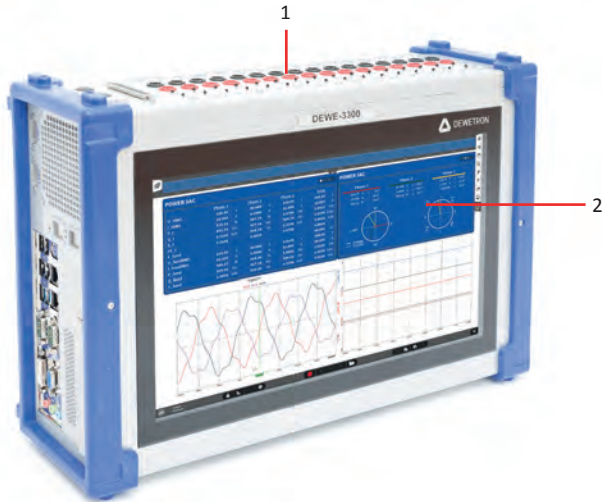

Typical DEWE-3300 top view

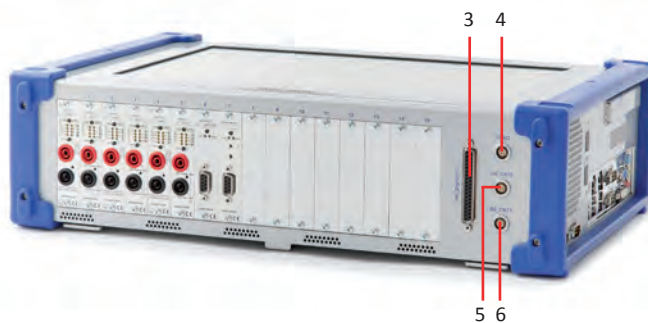

Typical DEWE-3300 left side view

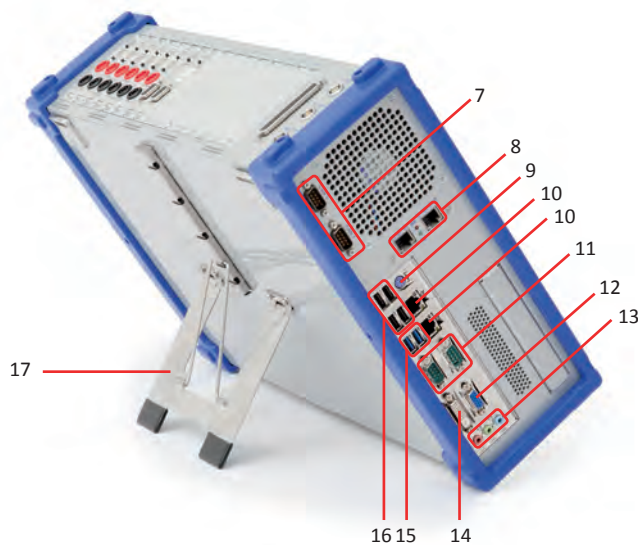

- 1 Slots for DAQP/HSI/PAD or MDAQ series modules (depending on configuration)
- 2 15.6" (1920 x 1080px) multi-touch Full HD display
- 3 Digital I/O connector
- 4 EPAD connector
- 5 Optional counter input (BO\_CNT0)
- 6 Optional counter input (BO\_CNT1)
- 7 CAN interface connector
- 8 ORION-DAQ-SYNC interface
- 9 PS/2 interface connector
- 10 Ethernet LAN connector
- 11 RS-232 interface connectors (COM1 & COM2)
- 12 VGA interface connector
- 13 Audio device (LINE IN, MIC, LINE OUT)
- 14 DVI interface connector  
External HDD access
- 15 USB 3.0 interface connector
- 16 USB 2.0 interface connector
- 17 Fold-out stand
- 18 Power supply input connector
- 19 HDD/SSD drive bays
- 20 Main power switch
- 21 Chassis terminal

Typical DEWE-3301 right side view



*Note: The location of the connectors (3), (4), (5), (6) vary from system to system and depend on system configuration. These connectors are not redundant.*

# MAIN SYSTEM

## 1 Slots for DAQP/HSI/PAD or MDAQ series modules

Depending on your model, the DEWE-330x supports either 16 slots for DAQP/HSI/PAD modules or up to 32 channels with differential inputs (MDAQ series modules). DAQP/HSI/PAD modules can be changed easily by the user while the MDAQ series modules come predefined and are not user exchangeable.

## 2 15.6" multi-touch display

The DEWE-3300 is equipped with a bright 15.6" Full HD (1920 x 1080px) multi-touch panel.

## 3 Digital I/O connector

This connector supports digital input and output lines of the built-in DEWE-ORION series board. If this board does not support digital I/O's, the connector is not available.

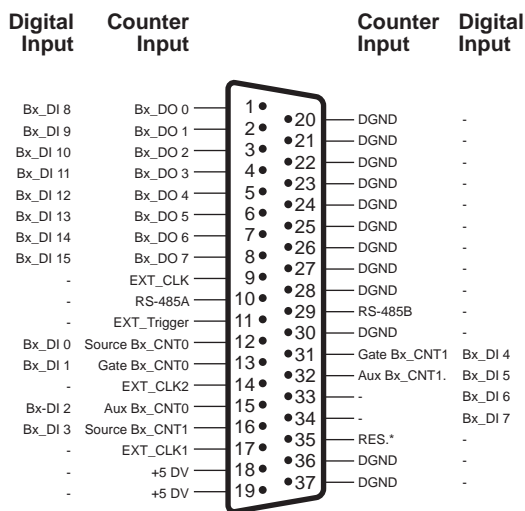

*Note: Only available for standard systems using ORION-xxxx cards!*

37-pin SUB-D connector

## 4 EPAD connector (LEMO)

To connect DEWETRON EPAD modules to the system.

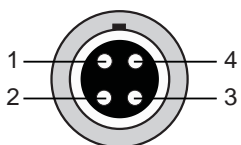

Lemo EGG.1B.304

Pin assignment

- 1: RS-485 A
- 2: RS-485 B
- 3: +12 V
- 4: GND

Shield is connected on housing

Mating connector:

- LEMO FGG.1B.304.CLAD52Z (for cable diameter 4.1 to 5.0 mm)
- LEMO FGG.1B.304.CLAD62Z (for cable diameter 5.1 to 6.0 mm)

## 5,6 Optional counter inputs (in conjunction with DEWE-ORION-xxxx boards)

- 1: Source Bx\_CNT(n)
  - 2: Aux\_Bx\_CNT(n)
  - 3: Gate Bx\_CNT(n)
  - 4: Power GND
  - 5: +5 V (max. 500 mA)
  - 6: +12 V (max. 500 mA)
  - 7: Signal GND
- n .. channels 0 to 1 of counter board

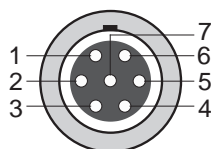

7-pin female LEMO connector  
EGG.1B.307

Mating connector:

- LEMO FGG.1B.307.CLAD52Z (for cable diameter 4.1 to 5.0 mm)
- LEMO FGG.1B.307.CLAD62Z (for cable diameter 5.1 to 6.0 mm)

Cable to open end, 5 m long:  
CTR-CBL-05

## 7 CAN interface connectors

This connector supports the CAN signals of the built-in A/D board. If this board does not support CAN signals, the connector is not available.

### CAN 0:

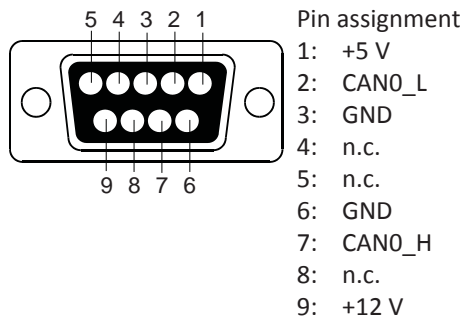

### CAN 1:

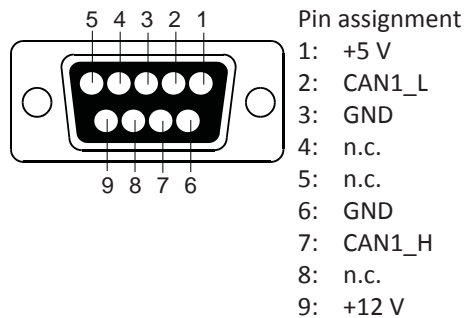

## 8 ORION-DAQ-SYNC

For high channel count or distributed systems, multiple instruments can be synchronized using the ORION-DAQ-SYNC option. To simply daisy-chain systems, standard CAT6 cables with RJ45 connectors can be used for short distances. The maximum length depends on the sampling rate and the A/D technology and ranges between 30 m to 200 m.

## 9 PS/2 interface connector

The PS/2 interface connector could be used to either connect a keyboard or an external PS/2 mouse. The connector meets standard PS/2 pin assignment.

## 10 Ethernet LAN connector

The DEWE-3300 system supports 10/100/1000 BaseT Ethernet with standard RJ45 connector.

## 11 RS-232 interface connectors (COM1 & COM2)

The RS-232 interface connectors (male) are configured as standard RS-232 interface COM 1 & COM 2 and can be used for mouse or other peripheral units.



9-pin SUB-D connector (male)

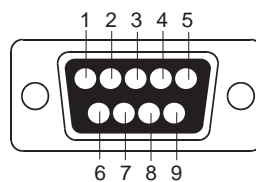

Schematic

### Pin assignment

- 1: DCD (Data Carrier Detector)
- 2: RD (Received Data)
- 3: TD (Transmitted Data)
- 4: DTR (Data Terminal Ready)
- 5: GND (Ground)
- 6: DSR (Data Set Ready)
- 7: RTS (Request To Send)
- 8: CTS (Clear To Send)
- 9: RI (Ring Indicator)

---

# MAIN SYSTEM

## 12,14 VGA/DVI connector

The VGA connector offers the possibility to connect a standard VGA displays to the system and meets standard VGA pin assignment. The DEWE-3300 offers an additional DVI connector.

## 13 Audio device

Connectors for LINE IN, MIC and LINE OUT.

## 15 USB3.0 interface connectors (Universal Serial Bus)

The USB3.0 interface connectors meet standard USB pin assignment.

## 16 USB2.0 interface connectors (Universal Serial Bus)

The USB2.0 interface connectors meet standard USB pin assignment.

## 17 Fold-out stand

The fold-out stand on the DEWE-3300 is designed to guarantee a secure stand and to facilitate touchscreen operations within a slight pitch of the instrument.

## 18 Power supply input connector

For details see chapter power supply.

## 19 HDD/SSD drive bays

The DEWE-3300 comes with 2 drivebays for easy access to your HDD/SSD including a 1 TB HDD dedicated for data storage as well as a 120 GB SSD for operating system and application software.

### Optional upgrades:

- > **HDD-1T-SSD-120G**  
Upgrade to industrial grade 120 GB solid state disk (replaces 1 TB harddisk)
- > **HDD-1T-SSD-500G**  
Upgrade to industrial grade 500 GB solid state disk (replaces 1 TB harddisk)
- > **HDD-1T-SSD-1T**  
Upgrade to industrial grade 1 TB solid state disk (replaces 1 TB harddisk)

---

### **CAUTION:** *Information for systems with SSD drives*



*Wait for 40 seconds after big files were deleted. The HDD activity LED is lit to indicate that the SSD is deleting the file and TRIM/garbage collection is in progress. Wait until the process is finished before you start to write the next file.*

---

## 20 Power-on switch

The power-on switch is used to switch on the system.

## 21 Chassis terminal

For some kind of measurements, it's necessary to provide the system with an additional ground connection.

### Optional connector for current power probe supply

This connector supports  $\pm 9$  V current power probe supply for connecting current clamps.

#### 3-pin Binder series connector

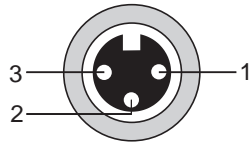

Pin assignment  
1: +9 V  
2: GND  
3: -9 V

*BINDER-712 series*

#### 6-pin male/female Lemo connector (with digital inputs of ORION board)

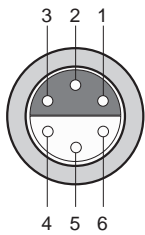

Pin assignment  
1: +15 V  
2: -15 V  
3: +9 V  
4: DGND  
5: DI(x)  
6: DGND

*Lemo ERA.1S.306*

x .. digital inputs 0..7 of the ORION board

# MAIN SYSTEM

## Possible configurations and panel options

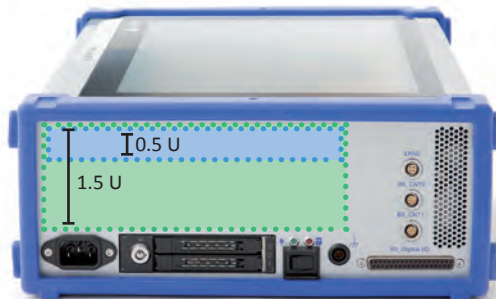

### 1.5 u panel space available for DIO panels in AC powered systems

Choose between a panel with 8 additional counter inputs or a power supply for 4 current clamps.

0.5U-ORION-CNT8-LEMO



0.5U-CLAMP-DC-POWER-4



### 1.5 u panel space available for DIO panels in systems with DC power option

Depending on the application, the DEWE-3300 offers various DIO panels. For encoder measurements the ORION-DIO-PANEL-1 is the right choice since it offers eight counters wired to 7-pin LEMO connectors. The ORION-DIO-PANEL-2 has been designed for applications where many TTL-inputs are required. For galvanically isolated digital inputs the ORION-DIO-PANEL-3 would be the right choice.

330x-OUT-10



ORION-DIO-PANEL-1



ORION-DIO-PANEL-2



MPAD-TH16-K

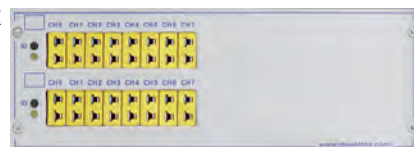

**NOTE:** Pinning of the optional ORION-DIO-PANELS are shown in the corresponding DEWE-ORION series technical reference manual. THESE PANELS ARE NOT USER EXCHANGEABLE! Please ask you local distributor or DEWETRON directly for more information.



## Power supply

### AC standard power supply

300 W AC power supply	P1S-6300V-B2
<b>Input:</b>	
Rated input range:	100 to 240 V <sub>AC</sub> , (max. 90 .. 264 V <sub>AC</sub> ) active PFC
Input frequency:	47 .. 63 Hz
Input current:	4.5 A @ 115 V / 2 A @ 230 V
<b>Output:</b>	
Output power:	300 W total
Output voltages:	+12 V1 (max. 8 A) +12 V2 (max. 16 A) +5 V (max 18 A) +3.3 V (max 17 A) -12 V (max. 0.3 A) +5 V <sub>sb</sub> (max. 2.5 A)
<b>Protection:</b>	
Short circuit protection:	+3.3 V, +5 V, +12 V, switch off / -12 V, +5 V <sub>sb</sub> , auto recovery
Overload protection:	110 .. 160 %, switch off
Overvoltage protection:	+3.3 V (+3.6 .. +4.3 V), +5 V (+5.6 .. +6.5 V), +12 V (+13.2 .. +15 V)



AC power supply

AC power switch

### DC power supply (option 3300-PS-DC-200)

250 W DC power supply	
<b>Input:</b>	
Input range:	Rated 11 to 27 V <sub>DC</sub> (max. 9 to 30 V <sub>DC</sub> )
Input frequency:	DC
<b>Output:</b>	
Output power:	max. 250 W
Output voltages:	+3.3 V (max. 15 A) +5 V (max. 15 A) +5 Vsb (max. 1.5 A) +12 V (max. 12 A) -12 V (max. 0.15 A)
12 V rail output current (12 V buck/boost converter)	
Input range:	12 V out current:
6 to 8 V:	8 A
8 to 11 V:	10 A (12 A peak)
11 to 16 V:	12 A (16 A peak)
16 to 30 V:	12 A (14 A peak)

Power supply pin assignment:



Connector type  
2-pin. male  
LEMO EGJ.2B.302

# MAIN SYSTEM

## External AC/DC power supply (standard accessory included with option 3300-PS-DC-200)

200 W AC power supply	
Input:	
Rated input voltage:	100 .. 240 V <sub>AC</sub> (max. 90 .. 264 V <sub>AC</sub> )
Input frequency:	47 .. 63 Hz
Output:	
Output power:	200 W total
Output voltage:	+24 V (max. 8.3 A)
Protection	
Overvoltage protection:	yes
Short circuit:	yes
Environment:	
Temperature:	Operating: 0 to 40 °C / Storage: -20 to 80 °C
Humidity:	Operating: 20 % RH to 80 % RH / Storage: 10 % RH to 90 % RH

*DEWE-3300 with option '3300-PS-DC-200'  
and included external AC/DC power supply*



Power supply pin assignment:



Connector type  
2-pin. male  
LEMO EGJ.2B.302

external AC/DC power supply  
100 to 240 V<sub>AC</sub> IN

## **A/D Conversion**

Please find information about the A/D conversion in the attached DEWE-ORION series manual.  
The latest version of the manual can be downloaded from:

<https://ccc.dewetron.com/pl/a-d-boards>

Informations regarding different manufacturer's see the corresponding D/A card manual.

▼

---

# A/D & D/A CONVERSION

Notes

## 16 slot DEWE-MOTHERBOARD DAQ-MOTH-16-DE-x

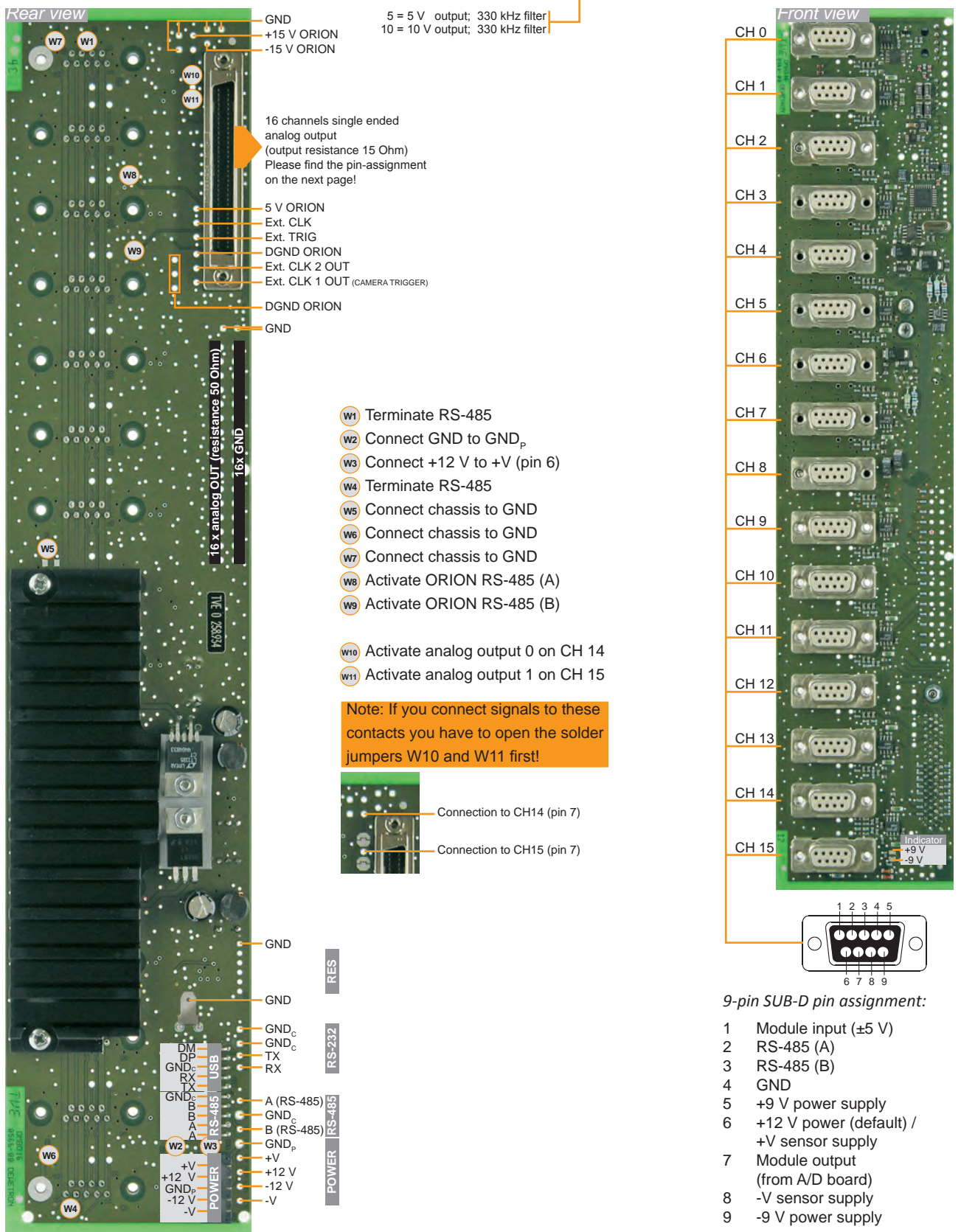

The 16 slot DEWE-MOTHERBOARD receives the  $\pm 12$  V<sub>DC</sub> power supply via a DC/DC converter from the internal power supply.

# INTERNAL WIRING

## Analog output connector pin-assignment

Connector for DEWE-ORION-1616 cards

+15 V	35 == 1	-15 V
AGND	36 == 2	AGND
AGND	37 == 3	AGND
AGND	38 == 4	CH15+
AGND	39 == 5	CH14+
AGND	40 == 6	CH13+
AGND	41 == 7	CH12+
AGND	42 == 8	CH11+
AGND	43 == 9	CH10+
AGND	44 == 10	CH9+
AISENSE2	45 == 11	CH8+
AGND	46 == 12	CH7+
AGND	47 == 13	CH6+
AGND	48 == 14	CH5+
AGND	49 == 15	CH4+
AGND	50 == 16	CH3+
AGND	51 == 17	CH2+
AGND	52 == 18	CH1+
AISENSE1	53 == 19	CH0+
AGND	54 == 20	AGND
DI8/DO0	55 == 21	DI0/Source(0)
DI9/DO1	56 == 22	DI1/Gate(0)
DI10/DO2	57 == 23	DI2/AUX_U_D(0)
DI11/DO3	58 == 24	DI3/Source(1)
DI12/DO4	59 == 25	DI4/Gate(1)
DI13/DO5	60 == 26	DI5/AUX_U_D(1)
DI14/DO6	61 == 27	RS-485A
DI15/DO7	62 == 28	RS-485B
+5 V	63 == 29	DI 6
DGND	64 == 30	DI 7
DGND	65 == 31	EXT_CLK
+5 V	66 == 32	EXT_Trigger
DGND	67 == 33	EXT_CLK1
DGND	68 == 34	EXT_CLK2

68-pin high density connector

Connector for DEWE-ORION-1624 cards

+15V	35 == 1	-15 V
AGND	36 == 2	AGND
AGND	37 == 3	AGND
CH. 15-	38 == 4	CH. 15+
CH. 14-	39 == 5	CH. 14+
CH. 13-	40 == 6	CH. 13+
CH. 12-	41 == 7	CH. 12+
CH. 11-	42 == 8	CH. 11+
CH. 10-	43 == 9	CH. 10+
CH. 9-	44 == 10	CH. 9+
CH. 8-	45 == 11	CH. 8+
CH. 7-	46 == 12	CH. 7+
CH. 6-	47 == 13	CH. 6+
CH. 5-	48 == 14	CH. 5+
CH. 4-	49 == 15	CH. 4+
CH. 3-	50 == 16	CH. 3+
CH. 2-	51 == 17	CH. 2+
CH. 1-	52 == 18	CH. 1+
CH. 0-	53 == 19	CH. 0+
AGND	54 == 20	AGND
NC.	55 == 21	NC.
NC.	56 == 22	NC.
NC.	57 == 23	NC.
NC.	58 == 24	NC.
NC.	59 == 25	NC.
NC.	60 == 26	NC.
NC.	61 == 27	RES.*
NC.	62 == 28	RES.*
+5 V	63 == 29	RES.*
DGND	64 == 30	RES.*
DGND	65 == 31	RES.*
+5 V	66 == 32	EXT-TRIGGER
DGND	67 == 33	SAMPLE CLOCK
DGND	68 == 34	NC.

\* DONT CONNECT

68-pin high density connector

## 16 slot DEWE-MOTHERBOARD DAQ-MOTH-16-NI-x-U

5 = 5 V output; 330 kHz filter  
 10 = 10 V output; 330 kHz filter  
 USB interface on-board

Connector for National Instruments™ A/D cards

DGND	35 == 1	PFI 14/P2.6
DGND	36 == 2	PFI 112/P2.4
PFI 8/P2.0	37 == 3	PFI 9/P2.1
PFI 7/P1.7	38 == 4	DGND
PFI 15/P2.7	39 == 5	PFI 6/P1.6
PFI 13/P2.5	40 == 6	PFI 5/P1.5
PFI 4/P1.4	41 == 7	DGND
PFI 3/P1.3	42 == 8	+5 V
PFI 2/P1.2	43 == 9	DGND
DGND	44 == 10	PFI 1/P1.1
PFI 10/P2.2	45 == 11	PFI 0/P1.0
PFI 11/P2.3	46 == 12	DGND
P0.3	47 == 13	DGND
P0.7	48 == 14	+5 V
P0.2	49 == 15	DGND
DGND	50 == 16	P0.6
P0.5	51 == 17	P0.1
P0.0	52 == 18	DGND
DGND	53 == 19	P0.4
AO GND	54 == 20	APFI 0
AO GND	55 == 21	AO 1
AI GND	56 == 22	AO 0
AI 7	57 == 23	AI 15
AI 14	58 == 24	AI GND
AI GND	59 == 25	AI 6
AI 5	60 == 26	AI 13
AI 12	61 == 27	AI GND
AI Sense	62 == 28	AI 4
AI 11	63 == 29	AI GND
AI GND	64 == 30	AI 3
AI 2	65 == 31	AI 10
AI 9	66 == 32	AI GND
AI GND	67 == 33	AI 1
AI 0	68 == 34	AI 8

68-pin high density connector

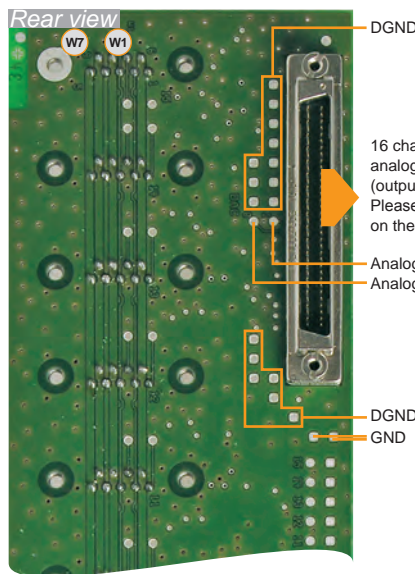

- W1 Terminate RS-485
- W2 Connect GND to GND<sub>p</sub>
- W3 Connect +12 V to +V (pin 6)
- W4 Terminate RS-485
- W5 Connect chassis to GND
- W6 Connect chassis to GND
- W7 Connect chassis to GND

---

# INTERNAL WIRING

Please find information about the MDAQ amplifiers in the attached DEWE-MDAQ series manual. The latest version of the manual can be downloaded from:

<https://ccc.dewetron.com/pg/mdaq-modules>

▼

---

# INTERNAL WIRING

Notes

---

# CE-Certificate of Conformity



Manufacturer:

**DEWETRON GmbH**

Address:

**Parking 4  
8074 Grambach, Austria**

Tel.: +43 316 3070 0

Fax: +43 316 3070 90

e-mail: sales@dewetron.com

http://www.dewetron.com

Name of product:

**DEWE-3300**

Kind of product:

*Data acquisition instrument*

The product meets the regulations of the following EC-directives:

**2014/35/EU**

**"Directive of the European Parliament and of the Council of 26 February 2014 on the harmonisation of the laws of the Member States relating to the making available on the market of electrical equipment designed for use within certain voltage limits"**

**2004/108/EC**

**"Directive on the approximation of the laws of the Member States relating to electromagnetic compatibility amended by the directives 89/336/EWG."**

The accordance is proved by the observance of the following standards:

<b>L V E M C</b>	<b>Safety</b>	IEC 61010-1:2011 300 V CATII, Pol. Deg. 2	
	<b>Emissions</b>	EN 61000-6-4	EN 55011 Class B
	<b>Immunity</b>	EN 61000-6-2	Group standard

**Graz, October 07, 2015**

Place / Date of the CE-marking

Ing. Thomas Propst / Manager Total Quality

▼  
NOTES

---