



DEWETRON

---

▼

# PAD-TH8-P Module

TECHNICAL REFERENCE MANUAL

---

▼

## WELCOME TO THE WORLD OF DEWETRON!

Congratulations on your new device! It will supply you with accurate, complete and reproducible measurement results for your decision making.

Look forward to the easy handling and the flexible and modular use of your DEWETRON product and draw upon more than 30 years of DEWETRON expertise in measurement engineering.

---

▼

ISO9001



**THE MEASURABLE DIFFERENCE.**

Copyright © DEWETRON GmbH

This document contains information which is protected by copyright. All rights are reserved. Reproduction, adaptation, or translation without prior written permission is prohibited, except as allowed under the copyright laws.

All trademarks and registered trademarks are acknowledged to be the property of their owners.

The information contained in this document is subject to change without notice.

DEWETRON GmbH (DEWETRON) shall not be liable for any errors contained in this document. DEWETRON MAKES NO WARRANTIES OF ANY KIND WITH REGARD TO THIS DOCUMENT, WHETHER EXPRESS OR IMPLIED. DEWETRON SPECIFICALLY DISCLAIMS THE IMPLIED WARRANTIES OF MERCHANTABILITY AND FITNESS FOR A PARTICULAR PURPOSE. DEWETRON shall not be liable for any direct, indirect, special, incidental, or consequential damages, whether based on contract, tort, or any other legal theory, in connection with the furnishing of this document or the use of the information in this document.

**Warranty Information:**

A copy of the specific warranty terms applicable to your DEWETRON product and replacement parts can be obtained from your local sales and service office.

**Restricted Rights Legend:**

Use austrian law for duplication or disclosure.

DEWETRON GmbH  
Parkring 4  
8074 Grambach  
Austria

**Printing History:**

Please refer to the page bottom for printing version.

Copyright © DEWETRON GmbH.

This document contains information which is protected by copyright. All rights are reserved. Reproduction, adaptation, or translation without prior written permission is prohibited, except as allowed under the copyright laws.

All trademarks and registered trademarks are acknowledged to be the property of their owners.

---

# ▼ Notice

## Safety symbols in the manual

---



*Indicates hazardous voltages.*

---

**WARNING** *Calls attention to a procedure, practice, or condition that could cause bodily injury or death.*

---

**CAUTION** *Calls attention to a procedure, practice, or condition that could possibly cause damage to equipment or permanent loss of data.*

---

### **WARNINGS**

*The following general safety precautions must be observed during all phases of operation, service, and repair of this product. Failure to comply with these precautions or with specific warnings elsewhere in this manual violates safety standards of design, manufacture, and intended use of the product. DEWETRON Elektronische Messgeraete Ges.m.b.H. assumes no liability for the customer's failure to comply with these requirements.*

---

**All accessories shown in this document are available as option and will not be shipped as standard parts.**

## Safety instructions for DEWETRON amplifiers

- The DEWETRON data acquisition systems and amplifiers may only be installed by experts.
- Read your manual carefully before operating.
- Observe local laws when using the amplifiers.
- Ground the equipment: For Safety Class 1 equipment (equipment having a protective earth terminal), a non interruptible safety earth ground must be provided from the mains power source to the product input wiring terminals or supplied power cable.
- DO NOT operate the product in an explosive atmosphere or in the presence of flammable gases or fumes.
- DO NOT operate damaged equipment: Whenever it is possible that the safety protection features built into this product have been impaired, either through physical damage, excessive moisture, or any other reason, REMOVE POWER and do not use the product until safe operation can be verified by service-trained personnel. If necessary, return the product to a DEWETRON sales and service office for service and repair to ensure that safety features are maintained.
- Keep away from live circuits: Operating personnel must not remove equipment covers or shields. Procedures involving the removal of covers or shields are for use by service-trained personnel only. Under certain conditions, dangerous voltages may exist even with the equipment switched off. To avoid dangerous electrical shock, DO NOT perform procedures involving cover or shield removal unless you are qualified to do so.
- No modifications are allowed at the amplifiers.
- DO NOT service or adjust alone. Do not attempt internal service or adjustment unless another person, capable of rendering first aid and resuscitation, is present.
- DO NOT substitute parts or modify equipment: Because of the danger of introducing additional hazards, do not install substitute parts or perform any unauthorized modification to the product. Return the product to a DEWETRON sales and service office for service and repair to ensure that safety features are maintained.
- DO NOT touch internal wiring!
- DO NOT use higher supply voltage than specified!
- Use only original plugs and cables for harnessing.
- Safety of the operator and the unit depend on following these rules.

# ▼ Support

---

For any support please contact your local distributor first or DEWETRON directly.

For Asia and Europe, please contact:

DEWETRON GmbH  
Parkring 4  
8074 Grambach  
AUSTRIA  
Tel.: +43 316 3070  
Fax: +43 316 307090  
Email: [support@dewetron.com](mailto:support@dewetron.com)  
Web: <http://www.dewetron.com>

The telephone hotline is available Monday to Friday between 08:00 and 12:00 CET (GMT -1:00) and Monday to Thursday between 13:00 and 17:00 CET.

For the Americas, please contact:

DEWETRON, Inc.  
2850 South County Trail, Unit 1  
East Greenwich, RI 02818  
U.S.A.  
Tel.: +1 401 284 3750  
Toll-free: +1 866 598 3393  
Fax: +1 401 284 3755  
Email: [us.support@dewetron.com](mailto:us.support@dewetron.com)  
Web: <http://www.dewetron.us>

The telephone hotline is available Monday to Friday between 08:00 and 17:00 GST (GMT +5:00)

# General Module Information

## Calibration information

All DEWETRON modules are calibrated at 25 °C after a warmup time of 30 minutes and meet their specifications when leaving the factory.

The time interval for recalibration depends on environmental conditions. Typically, the calibration should be checked once a year.

Calibration certificates are available from DEWETRON as an option. DEWETRON offers two types:

- ISO traceable DEWETRON certificate
- Calibration certificate according to ÖKD (equivalent to DKD)

This manual contains no calibration information. For self calibration, there is a separate calibration kit for the DAQ series modules available. The CAL-KIT contains the required cables, software and instructions.

## General module specifications

Module dimensions: 20 x 65 x 105 mm (0.79 x 2.56 x 4.13 in.)  
(W x H x D without front cover and connectors)

Frontcover: 20 x 87 x 2 mm (0.79 x 3.43 x 0.08 in.)  
(W x H x D without connector)

Environmental:

Temp. range storage: -30 °C to +85 °C (-22 °F to 185 °F)

Temp. range operating: -5 °C to +60 °C (23 °F to 140 °F)

Relative humidity

(MIL202): 0 to 95 % at 60 °C, non-condensing (unless otherwise noticed)

RFI susceptibility: ±0.5 % span error at 400 MHz, 5 W, 3 m

*All specifications within this manual are valid at 25 °C!*

All modules are produced according ISO9001 and ISO14001.

## Module connectors

Frontpanel connector: Accessable to the user. The connector type and pin assignment varies from module to module. Detailed pin assignment of each module is shown in the appropriate module description.

Rear connector: 9-pin male SUB-D, interface to the DEWE-System, not accessible to the user.



HSI/DAQx and PAD module  
rear view

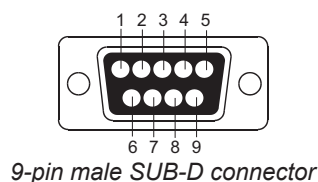

Interface pin assignment:

- 1 Module output ( $\pm 5$  V)
- 2 RS-485 (A)
- 3 RS-485 (B)
- 4 GND
- 5 +9 V power supply
- 6 +12 V power / sensor supply
- 7 Module input (from D/A converter of the A/D board)<sup>1)</sup>
- 8 reserved
- 9 -9 V power supply

<sup>1)</sup> Triggerout at DAQP-FREQ-A

# General Module Information

## RS-232/485 interface

HSI/DAQP modules can be configured via RS-485 interface, PAD modules require this interface for all data transfers.

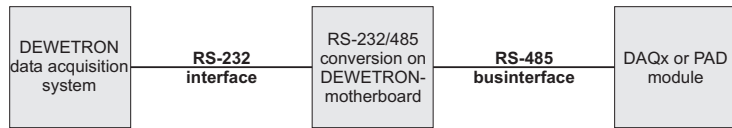

For all DEWETRON systems, an internal RS-232/485 converter is available

(standard with DEWE-800, -2000, -2500, -3000, -4000, -5000 series systems). This converter allows communication with HSI/DAQP and PAD modules.

To communicate with the modules, the RS-232 interface has to be set to the following parameters:

baud rate:	9600 bps
data bits:	8
parity:	no parity
stop bits:	1
handshake:	not required

## HSI/DAQP module configuration

### 1. Push button selection

All ranges and filters can be selected directly by pressing the push buttons on the module. Approx. 15 sec. after changing range and / or filter, the range and filter information is stored in an EEPROM. This procedure increases the lifetime of the EEPROM.

The current input range setting is shown all the time by LED. To change the range just press **RANGE** button a few times until the required range is displayed.

To see the current filter setting just press the **FILTER** button once. The corresponding LED is flashing for approx. 3 seconds. Within this time, the filter can be selected by pressing the **FILTER** button again. Approx. 3 seconds after the last key activity, the information will be stored, the LED stops flashing and shows the input range again.

---

**CAUTION:** Power loss during this time leaves the module in the former settings.

---

### 2. RS-232/485 programming

All ranges and filters can also be selected via RS-232/485 interface. All new DEWE-800, -2000, -2500, -3000, -4000, -5000 series systems are prepared as a standard to work with HSI/DAQP modules.

The easiest way to change the configuration is to use the DEWEConfig software, which comes as a standard with the DEWETRON data acquisition system.

Detailed information about HSI/DAQP modules programming for customer applications is available in the *DEWE-Modules Programmers Reference Manual*.

---

**CAUTION:** All range and filter changes which are done via RS-232/485 interface are not stored in the EEPROM of the HSI/DAQP modules! You have to store this information in a separat initialisation file to keep settings information for next system start!

---

## PAD module communication

All PAD modules are only working through the RS-232/485 interface. All new DEWE-800, -2000, -2500, -3000, -4000, -5000 series systems are prepared as a standard to work with PAD modules. The easiest way to change the configuration is to use the DEWEConfig software, which comes as a standard with the DEWETRON data acquisition system.

Detailed information about PAD modules programming for customer applications is available in the *DEWE-Modules Programmers Reference Manual*.

---

## 8 channel thermocouple and RTD amplifier

- Intelligent amplifier with integrated 24-bit A/D conversion
- 8 galvanic isolated input channels
- External CJC
- Automatic sensor block detection
- Signal connection via 25-pin SUB-D connector  
Direct thermocouple and RTD connection via  
PAD-CB8-xx connection block



## Module specifications

PAD-TH8-P		
	Revision 5.04 and lower	Revision 6.00 and higher
Input channels:	8 differential input channels	
Input voltage:	±1.5 V	
Input resistance:	1.4 MΩ	
Gain linearity:	0.001%	
Bandwidth:	3 Hz	6 Hz
Resolution:	1 μV (24-bit)	
Max. gain drift:	25 ppm /°C	
Max. offset drift:	25 ppm of range /°C	
Typical noise:	2 μV	
DC accuracy:	Better ±0.05 % ±200 μV (typ. ±0.03 % F.S. ±20 μV)	
Sampling rate:	Max. 6 Hz per channel	Max. 12 Hz per channel
Readout speed:	typ. 50 ch/sec.*	Typ. 80 ch/sec.*
Isolation voltage:	350 V <sub>DC</sub> channel to chassis ground 100 V <sub>DC</sub> channel to channel	
Overvoltage protection:	15 V <sub>DC</sub>	
NMR (50/60 Hz):	120 dB	
CMRR (50/60 Hz):	130 dB	
RS-485 interface:	Yes	
Interface speed:	9600 bps (2400 to 115200)	
Power supply voltage:	±9 V <sub>DC</sub> (±10 %)	
Power consumption:	Typical 0.6 W	

\*) Depending on system an number of channels

# PAD-TH8-P

## Signal connection

### General

To use the full power of the PAD-TH8-P module, a connection block should be ordered together with the module (CB8-x-P2 or CB8-x-M for thermocouples type K, J or T or CB-8-RTD for RTD sensors). The thermocouple type has to be specified at time of order. The thermocouple types on each CB-8-x-P2 connector block can be also mixed (e.g. 4 pcs. type K, 4 pcs. type J).

### PAD-TH8-P module



ID button  
Power state LED  
Programmable LED  
Input connector

1	Channel 0	(+)	13	Channel 6	(+)
2	Channel 0	(-)	14	Channel 6	(-)
3	Channel 1	(+)	15	Channel 7	(+)
4	Channel 1	(-)	16	Channel 7	(-)
5	Channel 2	(+)	17	Sensor identification (SI1)	
6	Channel 2	(-)	18	Sensor identification (SI2)	
7	Channel 3	(+)	19	Sensor identification (SI3)	
8	Channel 3	(-)	20	+12 V <sub>DC</sub>	
9	Channel 4	(+)	21	Reset (SI4)	
10	Channel 4	(-)	22	GND	
11	Channel 5	(+)	23	CJC	
12	Channel 5	(-)	24	CJC	
			25	CJC	

ID button: Used to define module address via software

Power state LED: Flashing when data transfer is active

Programmable LED: Free programmable state LED (on = standard; off or 1 Hz flashing programmable)

Reset procedure for firmware 5.04 and lower:

- Connect Pin 21 (Reset) to pin 22 (GND) on the DSUB-25 connector.
- Press the ID button during powering on the module.

Reset procedure for firmware 6.00 and higher:

- Press the ID button during powering on the module and keep it pressed for at least 3 more seconds.

Default values:

- Baud rate: 9600 Bps
- Address: 00h (equals a cleared module in DEWESoft)
- Data Format: engineering unit, no checksum

## Connection options for PAD-TH8-P modules

### PAD-CB8-x-P2 and PAD-CB8-x-M

*Be aware that PAD-CB8-x-P2 and PAD-CB8-x-M are only supported by PAD-TH8-P modules with firmware version 5 or later (delivered october 2002 or later).*

*Modules with older firmware supports only the PAD-CB8-x-P block, but can be upgraded. Please contact your local distributor for upgrade information.*



### Connector block specifications

PAD-CB8-x-P2 and PAD-CB8-x-M																					
Input channels:	8 isolated thermocouple input channels																				
Accuracy:	<table border="1"> <thead> <tr> <th>Thermocouple type J:</th> <th>Thermocouple type K:</th> <th>Thermocouple type T:</th> <th>Thermocouple type U:</th> </tr> </thead> <tbody> <tr> <td>±1.0 °C @ -200 to -100 °C</td> <td>±1.0 °C @ -200 to -25 °C</td> <td>±1.0 °C @ -200 to -150 °C</td> <td>±0.7 °C @ -200 to -100 °C</td> </tr> <tr> <td>±0.3 °C @ -100 to 150 °C</td> <td>±0.4 °C @ -25 to 120 °C</td> <td>±0.4 °C @ -150 to 400 °C</td> <td>±0.4 °C @ -100 to 0 °C</td> </tr> <tr> <td>±0.4 °C @ 150 to 400 °C</td> <td>±0.6 °C @ 120 to 400 °C</td> <td></td> <td>±0.3 °C @ 0 to 100 °C</td> </tr> <tr> <td>±1 °C @ 400 to 1200 °C</td> <td>±1 °C @ 400 to 1372 °C</td> <td></td> <td>±0.3 °C @ 100 to 600 °C</td> </tr> </tbody> </table> <p>Thermocouple type E, R, S, N, C or other types on request</p>	Thermocouple type J:	Thermocouple type K:	Thermocouple type T:	Thermocouple type U:	±1.0 °C @ -200 to -100 °C	±1.0 °C @ -200 to -25 °C	±1.0 °C @ -200 to -150 °C	±0.7 °C @ -200 to -100 °C	±0.3 °C @ -100 to 150 °C	±0.4 °C @ -25 to 120 °C	±0.4 °C @ -150 to 400 °C	±0.4 °C @ -100 to 0 °C	±0.4 °C @ 150 to 400 °C	±0.6 °C @ 120 to 400 °C		±0.3 °C @ 0 to 100 °C	±1 °C @ 400 to 1200 °C	±1 °C @ 400 to 1372 °C		±0.3 °C @ 100 to 600 °C
Thermocouple type J:	Thermocouple type K:	Thermocouple type T:	Thermocouple type U:																		
±1.0 °C @ -200 to -100 °C	±1.0 °C @ -200 to -25 °C	±1.0 °C @ -200 to -150 °C	±0.7 °C @ -200 to -100 °C																		
±0.3 °C @ -100 to 150 °C	±0.4 °C @ -25 to 120 °C	±0.4 °C @ -150 to 400 °C	±0.4 °C @ -100 to 0 °C																		
±0.4 °C @ 150 to 400 °C	±0.6 °C @ 120 to 400 °C		±0.3 °C @ 0 to 100 °C																		
±1 °C @ 400 to 1200 °C	±1 °C @ 400 to 1372 °C		±0.3 °C @ 100 to 600 °C																		
Typical noise:	±0.1 °C @ 6 Hz sampling; no average																				
CJC:	Internal																				
Operating temperature:	-25 to +80 °C (better on request)																				
Cable length:	2 m (up to 12 m on request)																				

### Dimensions PAD-CB8-x-M

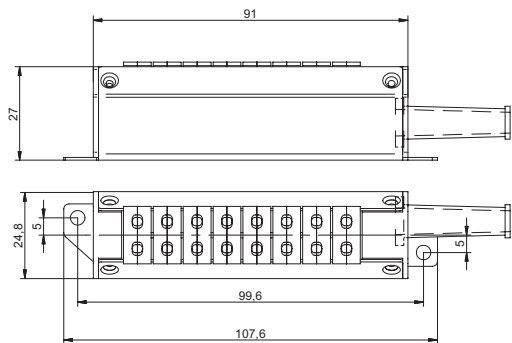

### Dimensions PAD-CB8-x-P2

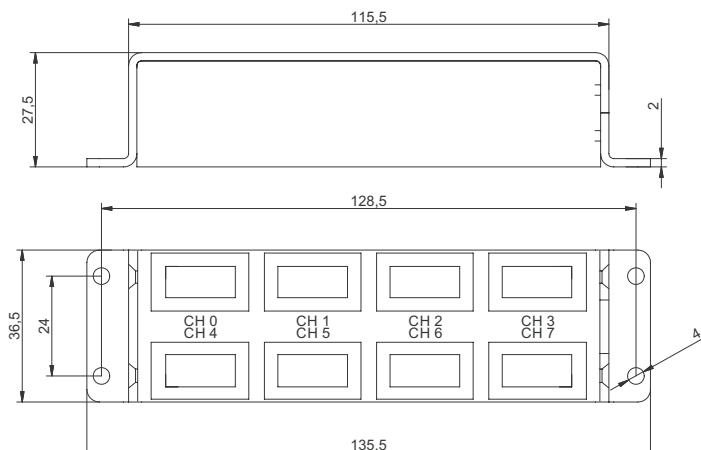

(Dimensions in mm; 1 inch = 25.4 mm)

# PAD-TH8-P

## PAD-CB8-RTD

Connector block for up to 8 RTDs type Pt100, Pt200, Pt500, Ni120, ... The sensor supply is galvanic isolated to the PAD-TH8-P.



### Connector block specifications

PAD-CB8-RTD	
Input channels:	8 RTDs
Constant current:	1250 $\mu$ A (CB8-RTD-S3: 250 $\mu$ A)
Constant current drift:	5 ppm/ $^{\circ}$ K
Connection types:	2-, 3- or 4-wire
Standard input ranges:	Resistor 0 to 999,99 Ohm, Pt100 a = 0.00385; Pt100 a = 0.003916; Pt200; Pt500; Ni120
CB8-RTD-S3:	Resistor 0 to 999,99 Ohm, Pt100 a = 0.00385; Pt100 a = 0.003916; Pt200; Pt500; Pt1000; Pt2000
Accuracy:	Pt100 a = 0.00385 $\pm 0.25^{\circ}$ C @ -200 to 100 $^{\circ}$ C $\pm 0.4^{\circ}$ C @ 100 to 400 $^{\circ}$ C $\pm 0.8^{\circ}$ C @ 400 to 800 $^{\circ}$ C
	Pt100 a = 0.003916 $\pm 0.25^{\circ}$ C @ -200 to 100 $^{\circ}$ C $\pm 0.4^{\circ}$ C @ 100 to 400 $^{\circ}$ C $\pm 0.8^{\circ}$ C @ 400 to 800 $^{\circ}$ C
	Pt200 a = 0.00385 $\pm 0.25^{\circ}$ C @ -200 to 100 $^{\circ}$ C $\pm 0.4^{\circ}$ C @ 100 to 400 $^{\circ}$ C $\pm 0.5^{\circ}$ C @ 400 to 630 $^{\circ}$ C
	Pt500 a = 0.00385 $\pm 0.25^{\circ}$ C @ -200 to 100 $^{\circ}$ C $\pm 0.4^{\circ}$ C @ 100 to 250 $^{\circ}$ C
Accuracy:	Pt1000 a = 0.00385 $\pm 0.25^{\circ}$ C @ -200 to 100 $^{\circ}$ C $\pm 0.4^{\circ}$ C @ 100 to 400 $^{\circ}$ C $\pm 0.8^{\circ}$ C @ 400 to 600 $^{\circ}$ C
	Pt2000 a = 0.00385 $\pm 0.25^{\circ}$ C @ -200 to 100 $^{\circ}$ C $\pm 0.4^{\circ}$ C @ 100 to 400 $^{\circ}$ C $\pm 0.8^{\circ}$ C @ 400 to 600 $^{\circ}$ C
	Ni120 $\pm 0.3^{\circ}$ C @ -80 to 100 $^{\circ}$ C $\pm 0.6^{\circ}$ C @ 100 to 260 $^{\circ}$ C
Typical noise:	0.01 $^{\circ}$ C
Operating temperature:	-25 to +80 $^{\circ}$ C
Cabel length:	2m (up to 12 m on request)
Dimensions (WxDxH):	approx. 196 x 57 x 32.2 mm (7.7 x 2.2 x 1.3 in.)

### Dimensions PAD-CB8-RTD

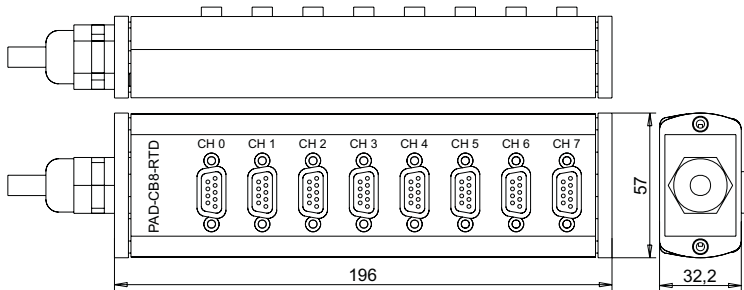

(Dimensions in mm; 1 inch = 25.4 mm)

### PAD-CB8-RTD block diagram

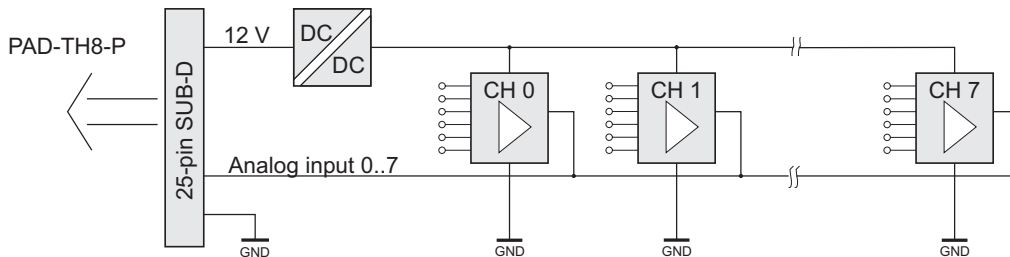

## PAD-OPT1

25-pin SUB-D connector with screw terminal and integrated CJC.  
(not included as a standard with module).

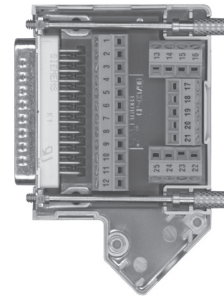

## Sensor connection

### 2-wire connection

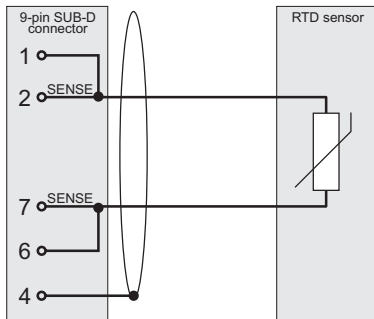

### 3-wire connection

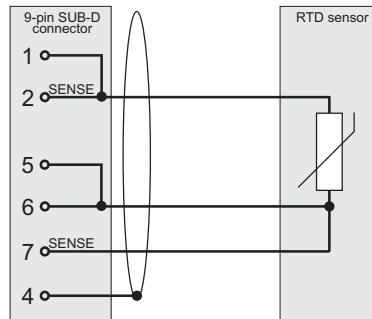

### 4-wire connection

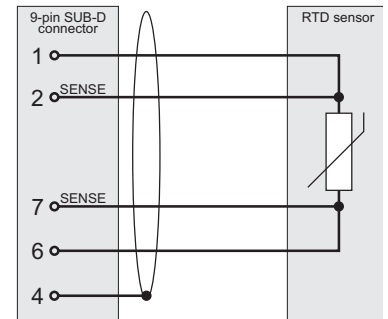

Measuring temperature with Pt100 or similar sensors is based on simple resistor measurements. Keep in mind that the resistance of the lead will influence the measurement result. The resistance changes with the temperature, the length and the diameter of the lead.

The 4-wire connection will completely remove all the measurement errors caused by lead resistance.

Using 2-wire connection the lead resistance will be within the measurement result. Especially using long and thin wires from the PAD-CB8-RTD to the temperature sensors will distort the measurement result.

The 3-wire connection will also compensate the lead resistance completely if all three wires have the same diameter and length. In that case it is safe to assume that the lead resistance of all three wires is the same. Therefore the resistance of only one wire has to be measured for eliminating the lead resistance influence.

*Be aware that the PAD-CB8-RTD is only supported by PAD-TH8-P modules with firmware version 5 or later (delivered October 2002 or later).*

▼  
**PAD-TH8-P**

---

**Notes**

---

# CE-Certificate of conformity



Manufacturer:

**DEWETRON GmbH**

Address:

**Parking 4  
8074 Grambach, Austria**

Tel.: +43 316 3070 0

Fax: +43 316 3070 90

e-mail: sales@dewetron.com

http://www.dewetron.com

Name of product:

**DEWE-MODULES**

Kind of product:

*Signal conditioning modules*

The product meets the regulations of the following EC-directives:

**73/23/EEC**

**"Directive on the approximation of the laws of the Member States relating to electrical equipment designed for use within certain voltage limits amended by the directive 93/68/EEC"**

**89/336/EEC**

**"Directive on the approximation of the laws of the Member States relating to electromagnetic compatibility amended by the directives 91/263/EEC, 92/31/EEC, 93/68/EEC and 93/97/EEC"**

The accordance is proved by the observance of the following standards:

<b>L V E M C</b>	<b>Safety</b>	IEC/EN 61010-1:1992/93 IEC 61010-1:1992/300 V CATIII Pol. D. 2 IEC/EN 61010-2-031 IEC 1010-2-031
	<b>Emissions</b>	EN 61000-6-4 EN 55011 Class B
	<b>Immunity</b>	EN 61000-6-2 Group standard

**Graz, April 28, 2010**

Place / Date of the CE-marking

Dipl.-Ing. Roland Jeutter / Managing director

▼  
Notes

---