

DEWE2-M7

TECHNICAL REFERENCE MANUAL

WELCOME TO THE WORLD OF DEWETRON!

Congratulations on your new device! It will supply you with accurate, complete and reproducible measurement results for your decision making.
Look forward to the easy handling and the flexible and modular use of your DEWETRON product and draw upon more than 25 years of DEWETRON expertise in measurement engineering.

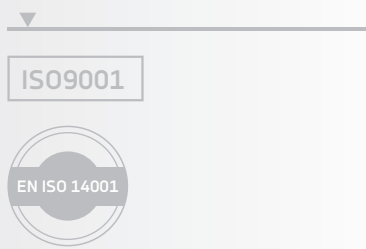

CUSTOMIZED



MODULAR



COMPETENT



COMMITTED



APPROVED

Copyright © DEWETRON GmbH

This document contains information which is protected by copyright. All rights are reserved. Reproduction, adaptation, or translation without prior written permission is prohibited, except as allowed under the copyright laws.

All trademarks and registered trademarks are acknowledged to be the property of their owners.
DEWESoft™ is a trademark of Dewesoft d.o.o

Thank you!

Thank you very much for your investment in DEWETRON's unique data acquisition systems. These are top-quality instruments which are designed to provide you years of reliable service. This guide has been prepared to help you get the most from your investment, starting from the day you take it out of the box, and extending for years into the future.

This guide includes important startup notes, as well as safety notes and information about keeping your DEWETRON system in good working condition over time.

We strongly suggest that you read this entire manual, especially the safety and care sections, as well as to avoid damaging your DEWETRON system.

What is the DEWE2-M7?

This product has seven slots for user exchangeable TRION™ series modules and is used for measuring of different physical and/or electrical sizes (depending on model or configuration). The connection is depending on model or configuration and takes place via safety banana plugs, BNC connectors ($\pm 50V$ max.), D-SUB connectors ($\pm 50V$ max.), thermocouple connectors ($\pm 50V$ max.), BINDER® connectors ($\pm 50V$ max.), SMB connectors ($\pm 50V$ max.), μ dot connectors ($\pm 50V$ max.), LEMO® connectors or RJ-45 connectors.

▼

PREFACE

Notes

Content

General Information, Safety Instructions	7
Training	7
Calibration	7
Support	7
Service/repairs	7
Warranty Information	8
Printing History	8
Safety conventions	9
General safety and hazard warnings for all DEWETRON systems	10
Maintenance	13
Windows updates and antivirus/security software	14
Problematic network stacks	14
Environmental Considerations	14
Main System	15
DEWE2-M7 - Data acquisition mainframe	15
System specifications	15
Dimensions	16
DEWE2-M7 at a glance	17
Power supply	20
Installing a TRION™ module into the DEWE2-M7	21
Maintenance	22
System recovery	22
Cooling considerations.....	23
CE-Certificate of conformity	C1

▼

TABLE OF CONTENT

Notes

Training

DEWETRON offers training at various offices around the world several times each year. DEWETRON headquarters in Austria have a very large and professional conference and seminar center, where training classes are conducted on a regular basis starting with sensors and signal conditioning, A/D technology and software operation. For more information about training services, please visit:

<http://www.dewetron.com/services/dewetron-academy/>

Dewetron Inc. in the USA also has a dedicated training facility connected to its headquarters, located in Rhode Island. For more information about training services in the US, please visit:

<http://www.dewetron.us/service-support/system-training-usa/>

Calibration

Every instrument needs to be calibrated at regular intervals. The standard norm across nearly every industry is annual calibration. Before your DEWETRON data acquisition system is delivered, it is calibrated at our DEWETRON headquarter. Each of this system is delivered with a certificate of compliance with our published specifications. Detailed calibration reports from our calibration system are available for purchase with each order. We retain them for at least one year, so calibration reports can be purchased for up to one year after your system was delivered.

Support

DEWETRON has a team of people ready to assist you if you have any questions or any technical difficulties regarding the system. For any support please contact your local distributor first or DEWETRON directly.

For Asia and Europe, please contact:

DEWETRON GmbH
Parkring 4
8074 Grambach
AUSTRIA
Tel.: +43 316 3070
Fax: +43 316 307090
Email: support@dewetron.com
Web: <http://www.dewetron.com>

The telephone hotline is available
Monday to Friday between
08:00 and 17:00 CET (GMT +1:00)

For the Americas, please contact:

DEWETRON, Inc. (HQ USA)
2850 South County Trail, Unit 1
East Greenwich, RI 02818
U.S.A.
Tel.: +1 401 284 3750
Toll-free: +1 866 598 3393
Fax: +1 401 284 3755
Email: us.support@dewetron.com
Web: <http://www.dewetron.us>

The telephone hotline is available
Monday to Friday between
08:00 and 4:30 EST

Service/repairs

Only the team of DEWETRON is allowed to perform any kinds of repairs to your system to assure a safe and proper operation in future. For information regarding service and repairs please contact your local distributor first or DEWETRON directly.



Any spare parts (screws, backplanes, cables,...) must be obtained from DEWETRON only.

▼ NOTICE

The information contained in this document is subject to change without notice.

DEWETRON GmbH (DEWETRON) shall not be liable for any errors contained in this document. DEWETRON MAKES NO WARRANTIES OF ANY KIND WITH REGARD TO THIS DOCUMENT, WHETHER EXPRESS OR IMPLIED. DEWETRON SPECIFICALLY DISCLAIMS THE IMPLIED WARRANTIES OF MERCHANTABILITY AND FITNESS FOR A PARTICULAR PURPOSE. DEWETRON shall not be liable for any direct, indirect, special, incidental, or consequential damages, whether based on contract, tort, or any other legal theory, in connection with the furnishing of this document or the use of the information in this document.

Warranty Information

A copy of the specific warranty terms applicable to your DEWETRON product and replacement parts can be obtained from your local sales and service office.

Restricted Rights Legend

Use austrian law for duplication or disclosure.

DEWETRON GmbH
Parkring 4
A-8074 Grambach / Austria

TRION™ is a trademark of DEWETRON GmbH.

Any other trademarks and registered trademarks are acknowledged to be the property of their owners.

Printing History

Please refer to the page bottom for printing version.

Copyright © DEWETRON GmbH.

This document contains information which is protected by copyright. All rights are reserved. Reproduction, adaptation, or translation without prior written permission is prohibited, except as allowed under the copyright laws.

Safety conventions



Observe precautions for handling electrostatic sensitive devices!



This icon denotes a caution, which advises you of precautions to take to avoid injury, data loss, or a system crash. When this symbol is marked on the product, refer to the technical reference manual.



Indicates hazardous voltages.



Indicates the chassis terminal

WARNING *Calls attention to a procedure, practice, or condition that could cause bodily injury or death.*

CAUTION *Calls attention to a procedure, practice, or condition that could possibly cause damage to equipment or permanent loss of data.*

WARNINGS

The following general safety precautions must be observed during all phases of operation, service, and repair of this product. Failure to comply with these precautions or with specific warnings elsewhere in this manual violates safety standards of design, manufacture, and intended use of the product. DEWETRON GmbH assumes no liability for the customer's failure to comply with these requirements.

SAFETY INSTRUCTIONS

Your safety is our primary concern! Please be safe!



General safety and hazard warnings for all DEWETRON systems

- > Use this system under the terms of the specifications only to avoid any possible danger. If the unit is used in a manner not specified by the manufacturer the protection can be impaired!
- > This product is intended for use in industrial locations. As a result, this product may cause interference if used in residential areas. Such use must be avoided unless the user takes special measures to reduce electromagnetic emissions to prevent interferences to the reception of radio and television broadcasts.
- > Maintenance will be executed by qualified staff only.
- > During the use of the system, it might be possible to access another parts of a more comprehensive system. Please read and follow the safety instructions provided in the manuals of all other components regarding warning and security advices for using the system.
- > With this product, only use the power cable delivered or defined for the host country.
- > **DO NOT** connect or disconnect sensors, probes or test leads, as these parts are connected to a voltage supply unit.
- > The system is grounded via a protective conductor in the power supply cord. To avoid electric shocks, the protective conductor has to be connected with the ground of the power network. Before connecting the input or output connectors of the system, make sure that there is a proper grounding to guarantee potential free usage. For countries, in which there is no proper grounding, please refer to your local legally safety regulations for safety use.

DC systems: Every DC system has a grounding connected to the chassis (yellow/green safety banana plug).

- > Please note the characteristics and indicators on the system to avoid fire or electric shocks. Before connecting the system, please carefully read the corresponding specifications in the product manual.
- > The inputs are not, unless otherwise noted (CATx identification), for connecting to the main circuits of category II, III and IV. The measurement category can be adjusted depending on module configuration.
- > The power cord separates the system from the power supply. Do not block the power cord, since it has to be accessible for the users.
- > Supply overvoltage category is II.
- > **DO NOT** use the system if equipment covers or shields are removed.
- > If you assume the system is damaged, get it examined by authorised personnel only.
- > Any use in wet rooms, outdoors or in adverse environmental condition is not allowed!
Adverse environmental conditions are:
 - > Moisture or high humidity
 - > Dust, flammable gases, fumes or dissolver
 - > Thunderstorm or thunderstorm conditions (except assembly PNA)
 - > Electrostatic fields, et cetera.
- > Any direct voltage output is protected with a fuse against short cut and reverse-polarity, but is **NOT** galvanically isolated (except it is explicit marked on the system).
- > The system must be connected and operated to an earthed wall socket at the AC mains power supply only (except for DC systems).
- > Any other use than described above may damage your system and is attended with dangers like shortcut, fire or electric shocks.

SAFETY INSTRUCTIONS

- > The whole system must not be changed, rebuilt or opened (except for changing TRION™ modules).
 - > If you assume a more riskless use is not provided anymore, the system has to be rendered inoperative and should be protected against inadvertent operation. It is assumed that a more riskless operation is not possible anymore, if
 - > the system is damaged obviously or causes strange noises.
 - > the system does not work anymore.
 - > the system has been exposed to long storage in adverse environmental.
 - > the system has been exposed to heavy shipment strain.
 - > DO NOT touch any exposed connectors or components if they are live wired. The use of metal bare wires is not allowed. There is a risk of short cut and fire hazard!
 - > Warranty void if damages caused by disregarding this manual. For consequential damages NO liability will be assumed!
 - > Warranty void if damages to property or persons caused by improper use or disregarding the safety instructions.
 - > Unauthorized changing or rebuilding the system is prohibited due to safety and permission reasons (CE). Exception: changing TRION™ modules.
 - > The assembly of the system is equivalent to protection class I. For power supply, only the correct power socket of the public power supply must be used, except the system is DC powered.
 - > Be careful with voltages $>25 V_{AC}$ or $>35 V_{DC}$! These voltages are already high enough in order to get a perilous electric shock by touching the wiring.
 - > Maximum input voltage for measuring cards are $70 V_{DC}$ and $46.7 V_{PEAK}$
 - > The product heats during operation. Make sure there is adequate ventilation. Ventilation slots must not covered!
 - > Only fuses of the specified type and nominal current may be used. The use of patched fuses is prohibited.
 - > Prevent using metal bare wires! Risk of short cut and fire hazard!
 - > DO NOT use the system before, during or shortly after a thunderstorm (risk of lightning and high energy overvoltage). An advanced range of application under certain conditions is allowed with therefore designed products only. For details please refer to the specifications.
 - > Make sure that your hands, shoes, clothes, the floor, the system or measuring leads, integrated circuits and so on, are dry.
 - > DO NOT use the system in rooms with flammable gases, fumes or dust or in adverse environmental conditions.
 - > Avoid operation in the immediate vicinity of:
 - > high magnetic or electromagnetic fields
 - > transmitting antennas or high-frequency generators
- For exact values please refer to enclosed specifications.
- > Use measurement leads or measurement accessories aligned to the specification of the system only. Fire hazard in case of overload!
 - > Do not switch on the system after transporting it from a cold into a warm room and vice versa. The thereby created condensation may damage your system. Acclimatise the system unpowered to room temperature.
 - > Do not disassemble the system! There is a high risk of getting a perilous electric shock. Capacitors still might be charged, even the system has been removed from the power supply.

SAFETY INSTRUCTIONS

- > Direct exposure of any DEWETRON product to strong sunlight or other heat radiation shall be prevented, as this could excessively heat up the product and lead to permanent damage of the product.
- > The electrical installations and equipments in industrial facilities must be observed by the security regulations and insurance institutions.
- > The use of the measuring system in schools and other training facilities must be observed by skilled personnel.
- > The measuring systems are not designed for use at humans and animals.
- > Please contact a professional if you have doubts about the method of operation, safety or the connection of the system.
- > Please be careful with the product. Shocks, hits and dropping it from already lower level may damage your system. For exact values please refer to enclosed specifications.
- > Please also consider the detailed technical reference manual as well as the security advices of the connected systems.

This product has left the factory in safety-related flawless and proper condition.

In order to maintain this condition and guarantee safety use, the user has to consider the security advices and warnings in this manual.

EN 61326-3-1:2008

IEC 61326-1 applies to this part of IEC 61326 but is limited to systems and equipment for industrial applications intended to perform safety functions as defined in IEC 61508 with SIL 1-3.

The electromagnetic environments encompassed by this product family standard are industrial, both indoor and outdoor, as described for industrial locations in IEC 61000-6-2 or defined in 3.7 of IEC 61326-1. Equipment and systems intended for use in other electromagnetic environments, for example, in the process industry or in environments with potentially explosive atmospheres, are excluded from the scope of this product family standard, IEC 61326-3-1.

Devices and systems according to IEC 61508 or IEC 61511 which are considered as “operationally well-tried”, are excluded from the scope of IEC 61326-3-1.

Fire-alarm and safety-alarm systems, intended for protection of buildings, are excluded from the scope of IEC 61326-3-1.

Maintenance

The information in this section is designed for use by qualified service personal.

Service interval:

Clean dust from the chassis exterior/interior and exchange filter foam based on the operating environment.

Cleaning:

Clean surface of the chassis with dry lintfree cloth.

Use a dry velocity stream of air to clean the chassis interior.



- > Disconnect all cables before servicing the unit!
- > Many components within the chassis are sensitive to static discharge damage. Always wear a ground wrist strap and service the unit only in static-free environment.
- > Do not use harsh chemical cleaning agents!

GENERAL INFORMATION

CAUTION

- > The system BIOS is protected by password. Any change in the BIOS may cause a system crash. When the system is booting, do not press ESC-button on keyboard. This may clear the BIOS settings and cause system faults.
- > Any change in the file structure as deleting or adding files or directories might cause a system crash.
- > Before installing software updates contact DEWETRON or your local distributor. Use only software packages which are released by DEWETRON. Further informations are also available in the internet (<http://www.dewetron.com>).
- > After power off the system wait at least 10 seconds before switching the system on again. Otherwise the system may not boot correct. This prolongs also the life of all system components.

Windows updates and antivirus/security software

Before installing Windows software updates consult with DEWETRON for compatibility guidance. Please also keep in mind that the use of any antivirus or other security software may slow down your system and may cause data loss.

Problematic network stacks

Often intrusive IT software or network processes can interfere with the primary function of the DEWETRON system: to record data. Therefore we recommend strongly against the installation of IT/MIS software and running their processes on any DEWETRON data acquisition system, and cannot guarantee the performance of our systems if they are so configured.



Environmental Considerations

Information about the environmental impact of the product.

Product End-of-Life Handling

Observe the following guidelines when recycling a DEWETRON system:

System and Components Recycling

Production of these components required the extraction and use of natural resources. The substances contained in the system could be harmful to your health and to the environment if the system is improperly handled at it's end of life! Please recycle this product in an appropriate way to avoid an unnecessary pollution of the environment and to keep natural resources.

This symbol indicates that this system complies with the European Union's requirements according to Directive 2002/96/EC on waste electrical and electronic equipment (WEEE). Please find further information about recycling on the DEWETRON website www.dewetron.com

Restriction of Hazardous Substances

This product has been classified as Monitoring and Control equipment, and is outside the scope of the 2011/65/EU RoHS Directive. This product is known to contain lead.

DEWE2-M7 - Data acquisition mainframe

- > 7 slots for TRION™ acquisition modules
- > Up to 56 analog inputs
- > Internal PCI slots available
- > 19" rack-mountable or benchtop use
- > EPAD2 interface connector



System specifications

DEWE2-M7	
Input channels	up to 56
Input specification	Supports all TRION™ series interface cards. Self-check functionality and detailed DEWETRON factory calibration report included
Open slots for TRION™ modules	7
High speed expansion	Prepared to connect one or more front-end chassis at any time by PCIe and SYNC interfaces
Quasi-static channel expansion	EPAD2 interface connector, CPAD2/3 via TRION-CAN
Main system ¹⁾	
PC configuration	Intel® Core™ i7 processor, 8 GB RAM 8 x USB, 2 x LAN Ethernet, 1 x external VGA socket, 2 x display port, AUDIO interface 64-bit Microsoft® Windows® 7 operating system (incl. 64-bit OXYGEN data acquisition software)
Data storage	1 TB HDD dedicated for data storage (upgrade to 4 TB HDD or 1 TB SSD available) 120 GB SSD for operating system and application software, both optional in a single removable drive bay
Rated input voltage	100 to 240 V _{AC} (max. 90 to 264 V _{AC}), 400 W AC power supply
Dimensions (W x D x H) (with 19" mounting kit)	without feet: 441 x 427 x 177 mm (17.4 x 16.8 x 7 in.) 5U required (4U = unit + 1U = cooling)
Weight w/o TRION™ modules	typ. 13 kg (28.6 lbs)
Power consumption incl. modules	Typ. 320 W
Environmental specifications	
Operating temperature	0 to +50 °C, down to -20 °C with prewarmed unit
Storage temperature	-20 to +70 °C
Humidity	10 to 80 % non cond., 5 to 95 % rel. humidity
Max. altitude	3000 m (10000 ft)
Sine vibration ¹⁾ (EN 60068-2-6)	Acceleration 20 m/s ² , Freq. 10 Hz - 150 Hz, Sweep 1 oct/min, 20 cycles
Shock ¹⁾ (EN 60028-2-27)	Acceleration 30 g, duration 11 ms, pulse form half sine, 3 pumps/direction, 6 directions
Random vibration ¹⁾ (EN 60721-3-2)	Class 2M2 (spectral acceleration density 1 m ² /s ³ , frequency range 10 Hz-200 Hz, duration 30 min/direction)
¹⁾ Tested with SSD	

MAIN SYSTEM

Dimensions

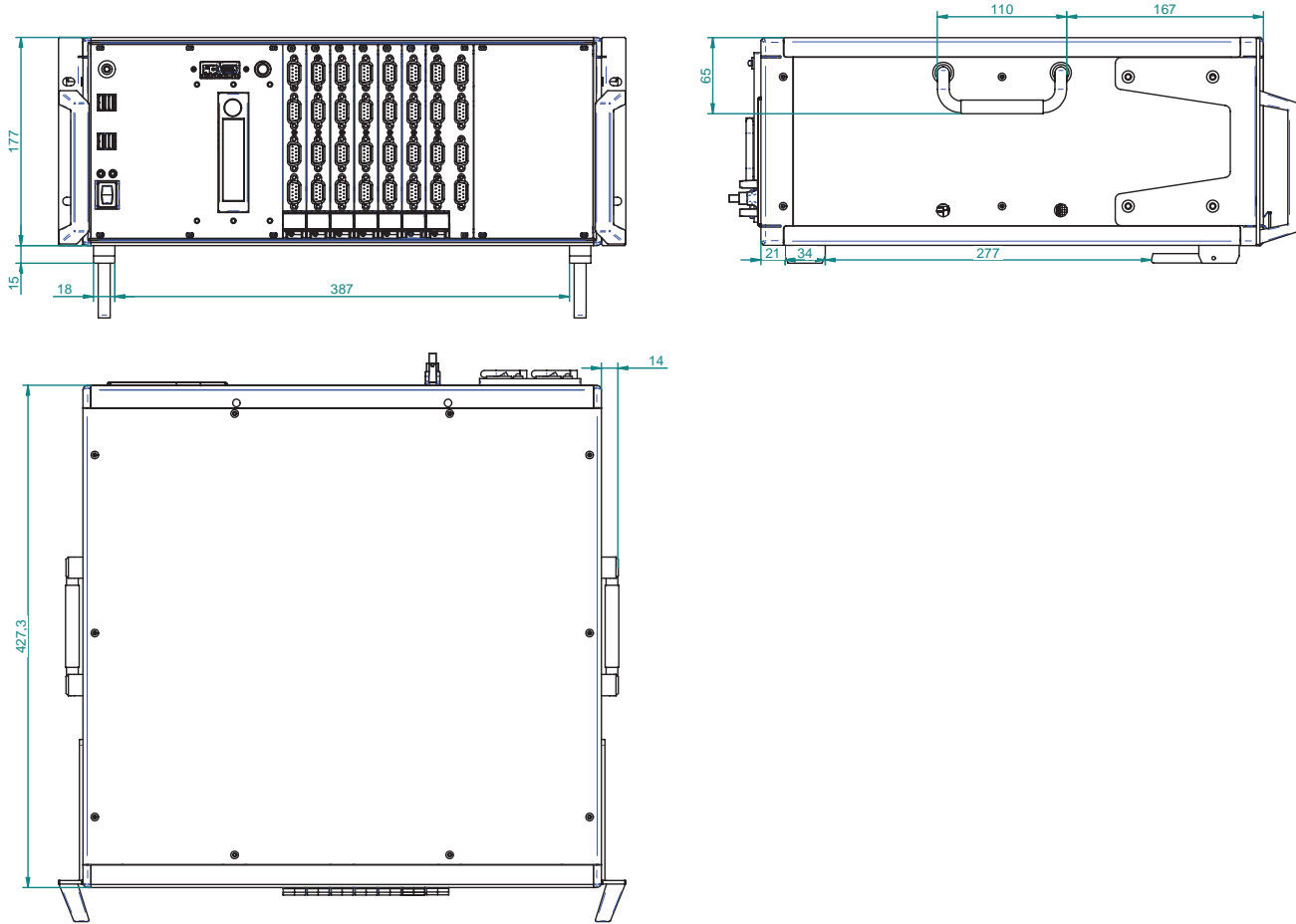

* Dimensions in mm
(1 inch = 25.4 mm)

DEWE2-M7 at a glance

- | | | | |
|---|------------------------------------|----|---|
| 1 | Chassis terminal | 8 | TRION™-SYNC-BUS |
| 2 | USB 2.0 interface connectors | 9 | Power supply input connector |
| 3 | Power-on switch | 10 | Main power switch |
| 4 | HDD/SSD drive bays (optional) | 11 | Gbit ethernet LAN connectors |
| 5 | TRION™ series module slots | 12 | Display port connectors |
| 6 | EPAD2 interface connector | 13 | DVI interface connector |
| 7 | Up- / Downstream interface PCIe x1 | 14 | Audio device |
| | | 15 | Expansion slots (2x PCI, 1x PCIe 4x, 1x PCIe 16x) |

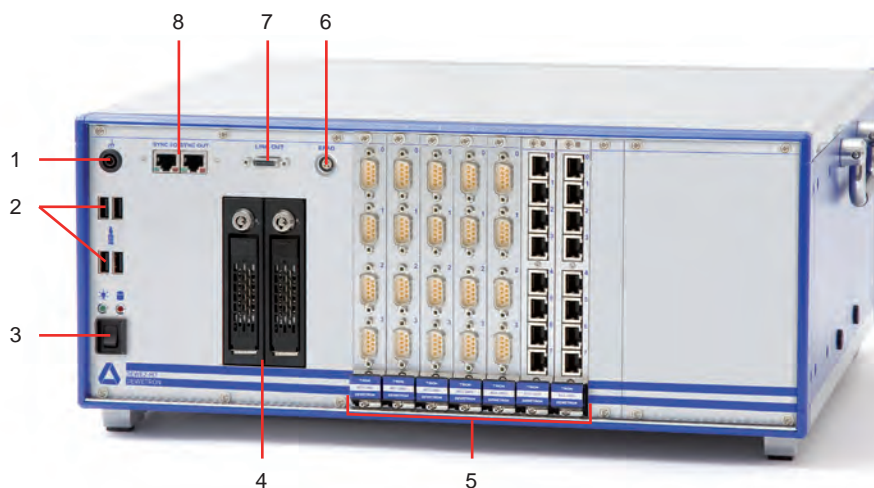

Typical DEWE2-M7 rear view

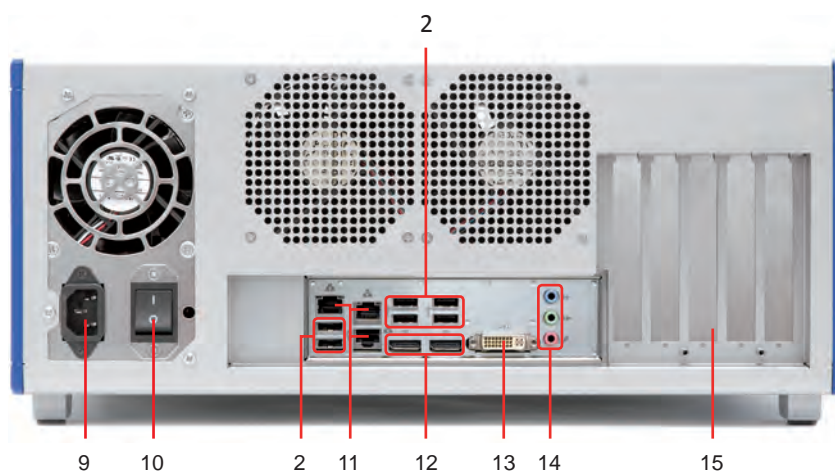

Note: The amount and location of the connectors might vary from system to system and depends on system configuration

MAIN SYSTEM

1 Chassis terminal

For some kind of measurements, it's necessary to provide the system with an additional ground connection.

2 USB2.0 interface connectors (Universal Serial Bus)

The USB2.0 interface connectors meet standard USB pin assignment.

3 Power-on switch

The power-on switch is used to switch on the system. It only works if the main power switch (9) is on.

4 HDD/SSD drive bays (optional)

The DEWE2-M7 comes with a internally installed 1 TB HDD dedicated for data storage as well as a 120 GB SSD for operating system and application software. As an option the DEWE2-M7 is upgradeable with 2 drivebays for easy access to your HDD/SSD.

Optional upgrades:

- > HDD-1T-4T: Upgrade from 1 TB hard disk to 4 TB hard disk
- > HDD-1T-SSD-256GB: Upgrade to industrial grade 256 GB solid state disk (replaces 1 TB harddisk)
- > HDD-1T-SSD-1TB: Upgrade to industrial grade 1 TB solid state disk (replaces 1 TB harddisk)
- > DW2-M13-BAY35: 3.5" SATA removable drive bay for one 2.5" SSD or 2.5" harddisk
No SSD or harddisk included
Applicable to DEWE2-M13 and DEWE2-M7
- > DW2-M13-BAY35-DUAL: 3.5" SATA removable drive bay for two 2.5" SSDs or harddisks
Fixed internal SSD and HDD are moved into the two drawers
Applicable to DEWE2-M13 and DEWE2-M7
- > HDD-2.5-SATA-1T: 1 TB SATA harddisk 2.5"

CAUTION: *Information for systems with SSD drives*



Wait for 40 seconds after big files were deleted. The HDD activity LED is lit to indicate that the SSD is deleting the file and TRIM/garbage collection is in progress. Wait until the process is finished before you start to write the next file.

5 TRION™ series module slots

7x slots for TRION™ series modules. The DEWE2-M7 supports all modules.

6 EPAD2 interface connector (LEMO)

To connect EPAD2 modules to the system.

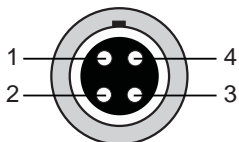

Lemo EGG.1B.304

Pin assignment

- 1: RS-485 A
- 2: RS-485 B
- 3: +12 V
- 4: GND

Shield is connected on housing

Mating connector: LEMO FGG.1B.304.CLAD52Z (for cable diameter 4.1 to 5.0 mm)
LEMO FGG.1B.304.CLAD62Z (for cable diameter 5.1 to 6.0 mm)

7 Up- / Downstream interface PCIe x1

The DEWE2-M7 is equipped with a PCI express x1 interface by default. In combination with the TRION™-SYNC-BUS **(8)** it allows easy high-speed channel expansion with F-series chassis.

8 TRION™-SYNC-BUS

The TRION™-SYNC-BUS in combination with the downstream interface connector **(9)** allows easy high-speed channel expansion with F-series chassis (e.g. DEWE2-F4s, F7...).

Sync cable has to be ordered separately:

DW2-CBL-SYNC-01:	Sync cable with RJ45 plugs, 1 m.
DW2-CBL-SYNC-03:	Sync cable with RJ45 plugs, 3 m.

9 Power supply input connector

For details see chapter power supply.

10 Main power switch

The main power switch has to be used to switch on the system.

11 GBit ethernet LAN connector

The DEWE2-M7 supports 10/100/1000 BaseT Ethernet with standard RJ45 connector.

12 Display ports

The display ports offer the possibility to connect a display to the system and meet standard pin assignment.

13 DVI connector interface

The DEWE2-M7 offers an additional DVI connector.

14 Audio I/O interface

Mic, Headphone & Line Out.

15 Expansion slots

The DEWE2-M7 supports up to 4 additional expansion slots:

- > 2x PCI
- > 1x PCIe 4x
- > 1x PCIe 16x

MAIN SYSTEM

Power supply

Standard AC power supply

400 W AC power supply	BEA-640
Input:	
Rated input voltage:	100 to 240 V _{AC} (max. 90 to 264 V _{AC}); active PFC
Input frequency:	47 to 63 Hz
Max. input current:	7 A (115 V _{AC}), 3.5 A (230 V _{AC})
Output:	
Output power:	max. 400 W
Output voltages:	+3.3 V (max. 28 A)
	+5 V (max. 35 A) -5 V (max. 0.5 A)
	+5 Vsb (max. 2 A)
	+12 V (max. 30 A) -12 V (max. 0.8 A)

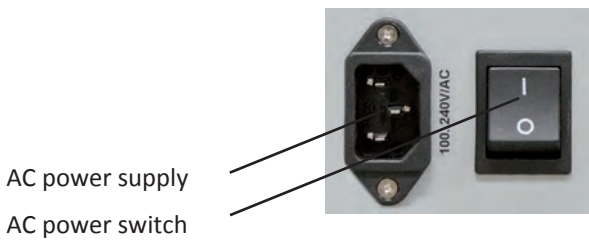

Installing a TRION™ module into the DEWE2-M7

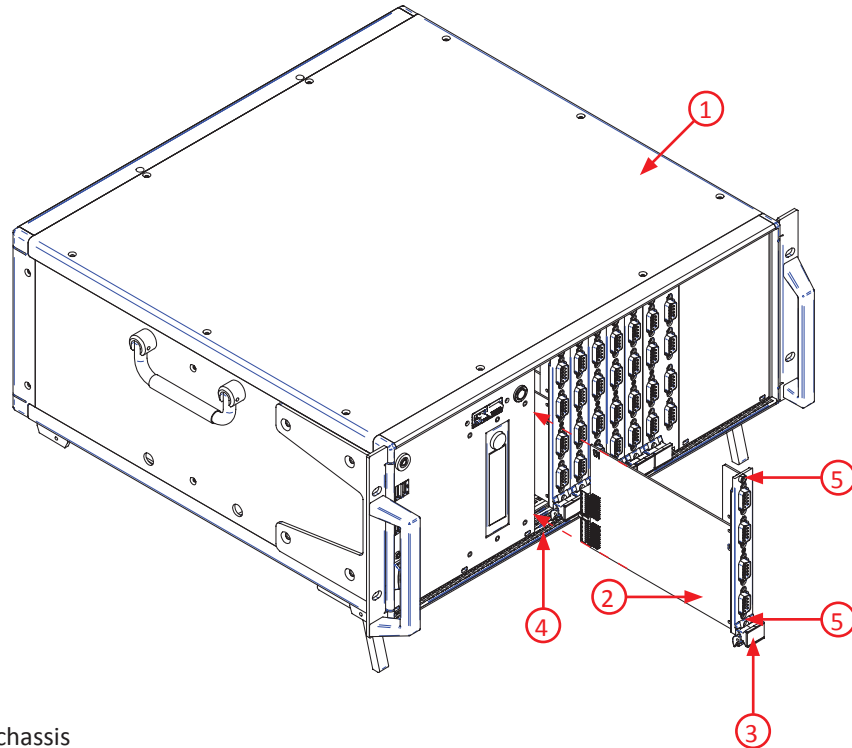

- 1 DEWE2-M7 chassis
- 2 TRION™ series module
- 3 Injector/ejector handle
- 4 Module guides
- 5 Mounting screws

Step 1:  Proper ESD precautions must be taken to avoid any damage to the unit.

Step 2: Power off and unplug all connected cables including sensors from the DEWE2-M7 and TRION™ series modules.

Step 3: Identify a supported TRION™ peripheral slot. Some modules require a TRION™ STAR-slot.

Step 4: Remove the filler panel of an unused TRION™ peripheral or STAR-slot.

Step 5: Place the module edges of the TRION™ modules into the module guides at the top and bottom of the chassis.

Step 6: Insert the TRION™ module to the rear of the chassis until a resistance appears.

Step 7: Pull up on the injector/ejector handle to latch the device

Step 8: Secure the installed TRION™ front panel to the chassis using the mounting screws.

 **WARNING:** *Unused TRION slots must not remain uncovered! Make sure to reinstall the filler panels of unused TRION™ slots to guarantee proper cooling of the installed modules. WARRANTY VOID if the modules overheat due to missing filler panels!*

MAIN SYSTEM

Maintenance

Battery

The battery in PC is CR 2032. It is allowed to replace this battery only by the same type. Replaceable only by serviceman.

Fuse

Fuse in power supply: F1 T8A or T6.3 A / 250 V. Replaceable only by serviceman.



Battery and fuse exchange has to be done by qualified persons only!

Installing the optional 19" mounting kit

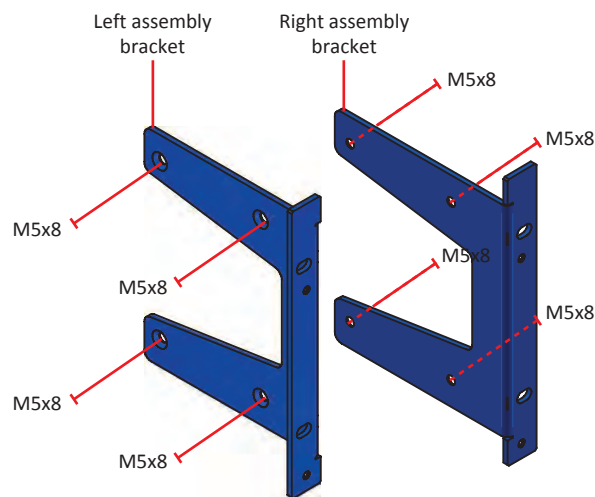

WARNING:

*When installing the 19" mounting brackets, the maximum length for screws is 8 mm!
If any screw gets lost replace it with M5x8 countersunk head screw only. Otherwise
the TRION™ series cards or the powersupply could get damaged!*



System recovery

For more information regarding a total recovery please refer to the corresponding total recovery technical reference manual shipped with your DEWE2 system.

Cooling considerations

The intake vent of the DEWE2-M7 is on the bottom of the chassis, where the cooling exhaust vent for the DEWE2-M7 is on the rear of the chassis.

CAUTION: *Adequate clearance between the chassis and surrounding equipment or blockages must be maintained to ensure proper cooling of the chassis power supply as well as the modules plugged into the chassis!*

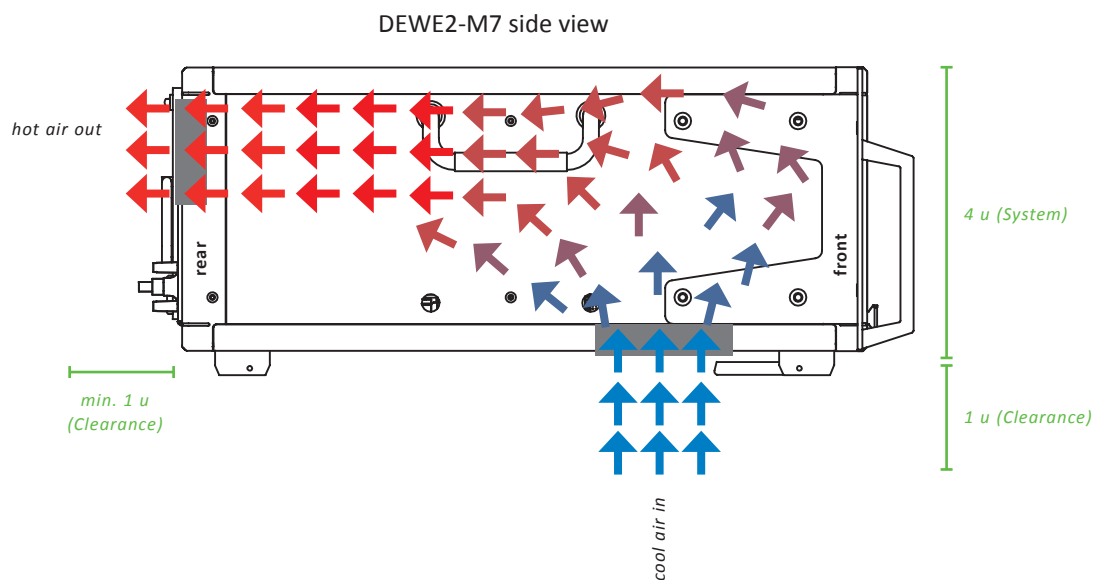

NOTE: *When installing the DEWE2-M7 into a 19" cabinet please keep in mind that the unit is siphoning air from the bottom (see schematic above). Due to this circumstances 5 u are required for one system (4 u = system + 1 u = cooling)! Otherwise the system may overheat and could get damaged!*



▼
MAIN SYSTEM

Notes

CE-Certificate of Conformity



Manufacturer:

DEWETRON GmbH

Address:

**Parking 4
8074 Grambach, Austria**

Tel.: +43 316 3070 0

Fax: +43 316 3070 90

e-mail: sales@dewetron.com

http://www.dewetron.com

Name of product:

DEWE2-M7

Kind of product:

Data acquisition mainframe

The product meets the regulations of the following EC-directives:

2014/35/EU

"Directive of the European Parliament and of the Council of 26 February 2014 on the harmonisation of the laws of the Member States relating to the making available on the market of electrical equipment designed for use within certain voltage limits"

2004/108/EC

"Directive on the approximation of the laws of the Member States relating to electromagnetic compatibility amended by the directives 89/336/EWG."

The accordance is proved by the observance of the following standards:

L V E M C	Safety	IEC 61010-1:2011 300 V CATII, Pol. Deg. 2	
	Emissions	EN 61000-6-4	EN 55011 Class B
	Immunity	EN 61000-6-2	Group standard

Graz, May 22, 2017

Place / Date of the CE-marking

Ing. Thomas Propst / Manager Total Quality

▼
NOTES
