



DEWETRON

# AUTOMOTIVE R.7.1

OXYGEN MANUAL



ISO 9001

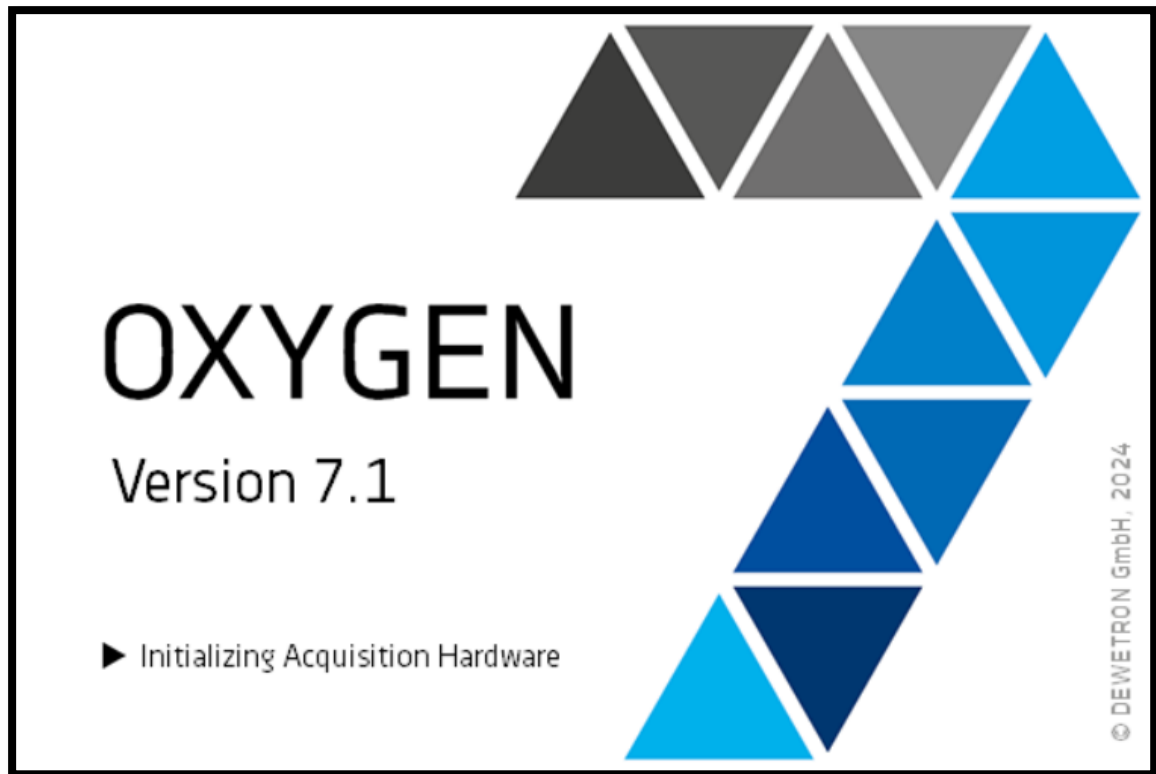

Copyright © DEWETRON GmbH

This document contains information which is protected by copyright. All rights are reserved. Reproduction, adaptation, or translation without prior written permission is prohibited, except as allowed under the copyright laws.

All trademarks and registered trademarks are acknowledged to be the property of their owners.

The information contained in this document is subject to change without notice.

DEWETRON GmbH (DEWETRON) shall not be liable for any errors contained in this document. DEWETRON MAKES NO WARRANTIES OF ANY KIND ABOUT THIS DOCUMENT, WHETHER EXPRESS OR IMPLIED. DEWETRON SPECIFICALLY DISCLAIMS THE IMPLIED WARRANTIES OF MERCHANTABILITY AND FITNESS FOR A PARTICULAR PURPOSE.

DEWETRON shall not be liable for any direct, indirect, special, incidental, or consequential damages, whether based on contract, tort, or any other legal theory, in connection with the furnishing of this document or the use of the information in this document.

## Technical Support

Please contact your local authorized DEWETRON representative first for any support and service questions.

For Asia and Europe, please contact:

### DEWETRON GmbH

Parkring 4  
8074 Grambach  
AUSTRIA

Tel.: +43 316 3070  
Fax: +43 316 307090  
Email: [support@dewetron.com](mailto:support@dewetron.com)  
Web: <http://www.dewetron.com>

The telephone hotline is available Monday to Friday between 08:00 and 17:00 CET (GMT +1:00)

For America, please contact:

### DEWETRON, Inc.

2850 South County Trail, Unit 1  
East Greenwich, RI 02818  
U.S.A.

Tel.: +1 401 284 3750  
Toll-free: +1 877 431 5166  
Fax: +1 401 284 3755  
Email: [support@dewamerica.com](mailto:support@dewamerica.com)  
Web: <http://www.dewamerica.com>

The telephone hotline is available Monday to Friday between 08:00 and 17:00 GST (GMT -5:00)

## Restricted Rights Legend:

Use Austrian law for duplication or disclosure.

### DEWETRON GmbH

Parkring 4  
8074 Grambach  
AUSTRIA

## Printing History:

Please refer to the page bottom for printing version. Copyright © DEWETRON GmbH

This document contains information which is protected by copyright. All rights are reserved. Reproduction, adaptation, or translation without prior written permission is prohibited, except as allowed under the copyright laws.

All trademarks and registered trademarks are acknowledged to be the property of their owners.

Before updating your software please contact DEWETRON. Use only original software from DEWETRON.

Please find further information at [www.dewetron.com](http://www.dewetron.com).

# Table of Contents

1	ADMA PLUGIN .....	6
1.1	INSTALLATION .....	6
1.2	PLUGIN LICENSING .....	6
1.3	OVERVIEW.....	7
1.4	ADMA STREAM CONFIGURATION.....	8
1.5	SYNCHRONIZATION OF ADMA AND ANALOG DATA .....	10
2	OXTS PLUGIN .....	12
2.1	INSTALLATION .....	12
2.2	PLUGIN LICENSING .....	12
2.3	OVERVIEW.....	13
2.4	RT STREAM CONFIGURATION.....	14
2.5	TROUBLESHOOTING.....	15
2.6	SYNCHRONIZATION OF RT AND ANALOG DATA .....	16
3	OXYGEN AUTOMOTIVE PLUGIN – OVERVIEW.....	17
3.1	INSTALLATION .....	17
3.2	PLUGIN LICENSING .....	17
3.3	SETUP MENU.....	18
3.4	LOCATION MENU .....	19
3.4.1	OVERVIEW.....	19
3.4.2	IMPORTING AND POSITIONING OF BACKGROUND IMAGES .....	19
3.4.3	COORDINATE SYSTEM DEFINITION .....	21
3.5	OBJECTS MENU.....	23
3.5.1	OVERVIEW.....	23
3.5.2	VEHICLES (MOVING OBJECTS).....	23
3.5.3	CONES (POSITION OBJECTS) .....	26
3.5.4	LOCATORS .....	28
3.5.5	KML TRACKS .....	30
3.5.6	TRACK LINES .....	31
3.5.7	DIN 70000 vs SAE COORDINATE SYSTEM.....	32
3.6	CALCULATIONS MENU .....	33
3.6.1	OVERVIEW.....	33
3.6.2	DEFINING A DISTANCE CALCULATION - CALCULATION OBJECT SETTINGS .....	34
3.6.3	CALCULATION - DISTANCE TYPE SELECTION .....	35
3.6.4	CALCULATION– SIGN SELECTION.....	42
3.7	CONTOUR EDITOR MENU.....	44
3.7.1	OVERVIEW.....	44
3.7.2	CREATING A CARS’ SHAPE AND POIS WITH THE CONTOUR EDITOR.....	45
4	BIRDSEYE INSTRUMENT .....	49

5	APPENDIX: LIST OF DECODED ADMA CHANNELS.....	50
5.1	ADMANET-DATA .....	50
5.2	ADDON DELTA DATA .....	58
5.3	ADMA BRAKING DATA .....	59
6	APPENDIX: LIST OF DECODED OXTS CHANNELS.....	61
7	LIST OF FIGURES .....	66
8	LIST OF TABLES .....	68

---

## *PREFACE*

---

DEWETRONs Automotive software solution consists of three independent plugins: the ADMA plugin, the Oxts plugin and the OXYGEN Automotive plugin.

An IMU (ADMA or Oxts) plugin is required to acquire synchronized measurement data of multiple IMU/GNSS sensors. Since OXYGEN R3.4, GeneSys ADMA IMUs (ADMA-G, ADMA-SPEED and ADMA-SLIM) and Oxts RT IMUs (providing a NCOM datastream, i.e. RT1003, RT2000, RT3000 and RT4000 or a RCOM datastream, i.e. RT-Range) are supported.

Analog data acquired by DEWETRON TRION-modules can be synchronized to IMU data streams by clocking the TRION hardware to the PPS pulse which is generated out of the GPS time and provided by the IMU. For details, please refer to section 1.5 and 2.6.

Data of ADMAs and Oxts IMUs can be acquired in parallel. As both data streams of ADMAs and Oxts RTs are clocked by the GPS time, data of both IMUs will be acquired time-synchronously by OXYGEN. For synchronizing analog data in addition, the PPS pulse provided either by the ADMA or by the Oxts RT can be used.

Up to 3 ADMA devices with 1 ADMAnet and 1 ADMAdelta stream each allows to acquire 6 data streams simultaneously. Alternatively, up to 6 ADMA devices with 1 ADMAnet each allows to acquire 6 data streams simultaneously as well. Details can be found in section 1.

The OXYGEN Automotive plugin (see section 3) is required to visualize moving and stationary objects and to calculate distances between these objects and their POIs.

To visualize the objects online during the measurements and during data analysis, OXYGENs BirdsEye instrument can be used which is introduced in section 4.

This manual is only about the OXYGEN Automotive software solution. For general OXYGEN features, please refer to the latest OXYGEN Feature Manual which can be downloaded from the CCC portal:

<https://ccc.dewetron.com/>

# 1 ADMA PLUGIN

The ADMA plugin allows for an acquisition of up to 6 UDP streams from up to 6 GeneSys ADMAs (every ADMA can potentially output more than one UDP stream) in OXYGEN.

Please note that the support of ADMAs is completely passive, thus OXYGEN can only acquire data from the ADMA. ADMAs cannot be configured via OXYGEN. The ADMA configuration must be done via the web interface of the ADMA.

The acquired data can be either SW-synchronized (i.e. two or more ADMAs are synchronized to each other but analog data is asynchronous to ADMA data) or HW-synchronized (i.e. ADMA data is synchronized also to analog data).

To suit various applications, the plugin offers different channel collections to acquire either the complete ADMA data set, or a subset.

The integrated unit-conversion allows for rescaling of the ADMAs output units to pre-defined units for distance, velocity and acceleration.

## 1.1 INSTALLATION

The ADMA plugin is automatically installed with every Oxygen R3.2 (June 2018) and above. Once installed, the plugin needs to be licensed (if not done by DEWETRON factory already) and activated.

## 1.2 PLUGIN LICENSING

The plugin license can be updated under the System Information tab (see Figure 1-1). This requires a \*.lic-file provided by DEWETRON. A license update requires a restart of Oxygen.

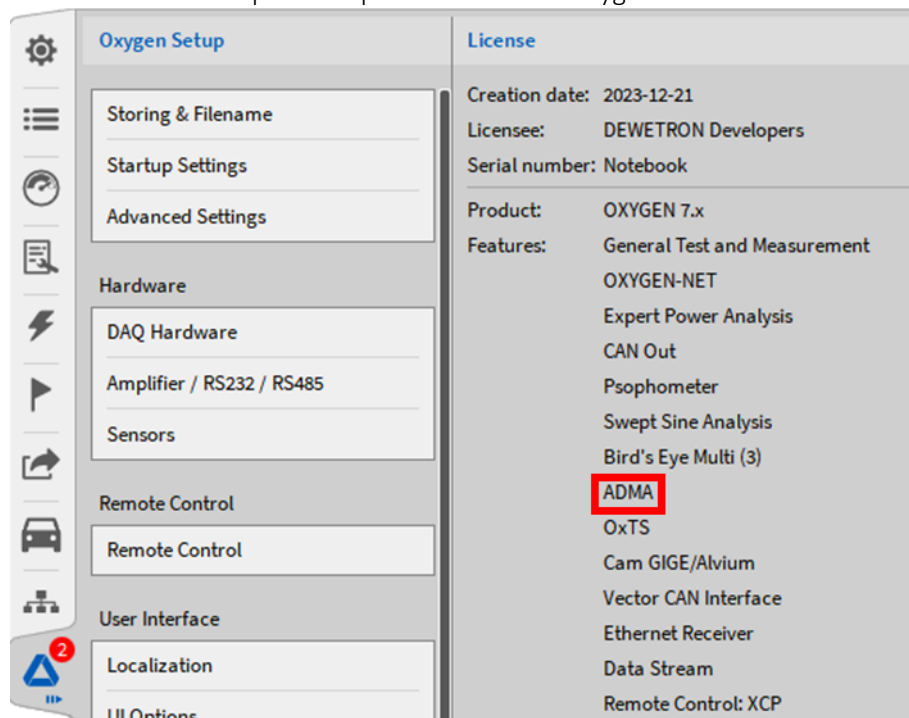

Figure 1-1: Updating the OXYGEN-license

## 1.3 OVERVIEW

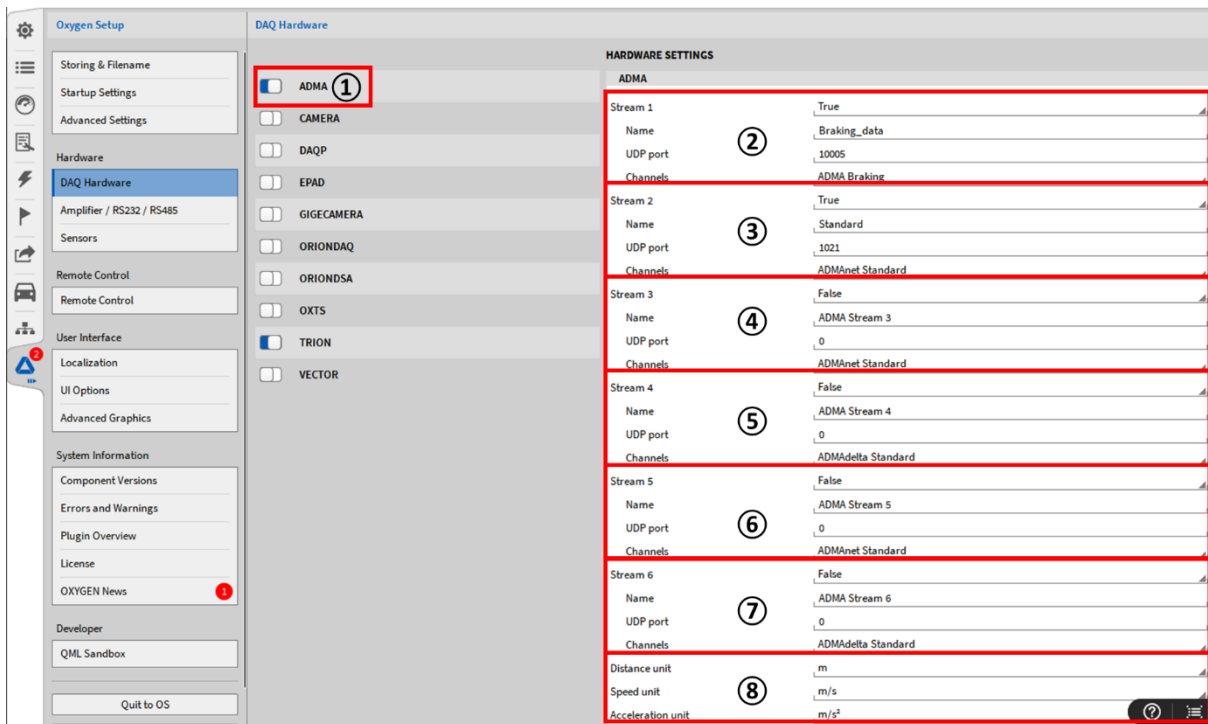

Figure 1-2: DAQ-hardware setup - ADMA settings

1	Enable ADMA hardware	Enables/Disables data acquisition from ADMAs
2	ADMA Stream 1 settings	Settings for data stream 1
3	ADMA Stream 2 settings	Settings for data stream 2
4	ADMA Stream 3 settings	Settings for data stream 3
5	ADMA Stream 4 settings	Settings for data stream 4
6	ADMA Stream 5 settings	Settings for data stream 5
7	ADMA Stream 6 settings	Settings for data stream 6
8	Unit settings	Settings for the unit conversion

Table 1-1: DAQ hardware setup - ADMA settings

To enable the data acquisition by the ADMA, go to the *DAQ Hardware* setup that can be found in the *System Settings* and enable *ADMA* hardware (see ① in Figure 1-2). A software restart is required after enabling DAQ hardware.

Up to 6 UDP streams can be acquired by OXYGEN simultaneously. The settings for the single ADMA streams can be found in ②, ③, ④, ⑤, ⑥ and ⑦ of Figure 1-2. For details, please refer to section 1.4.

The desired unit of the data channels acquired by the ADMA can be selected in ⑧ of Figure 1-2. For details, please refer to section 1.4.

**Remark:** Please note that the settings in the DAQ hardware setup are not stored to an OXYGEN setup (dms) file. These settings are only stored to the registry. The advantage is that the settings must only be done once on the same PC and may remain untouched afterwards. But be aware that the settings must be done on another PC if the dms-setup file is copied and loaded there!

The single data channels acquired by the individual stream can be found in the channel list if the data stream is enabled. An own ADMA enclosure will show up in the Channel List topology containing all activated ADMA streams containing the individual channels (see Figure 1-3).

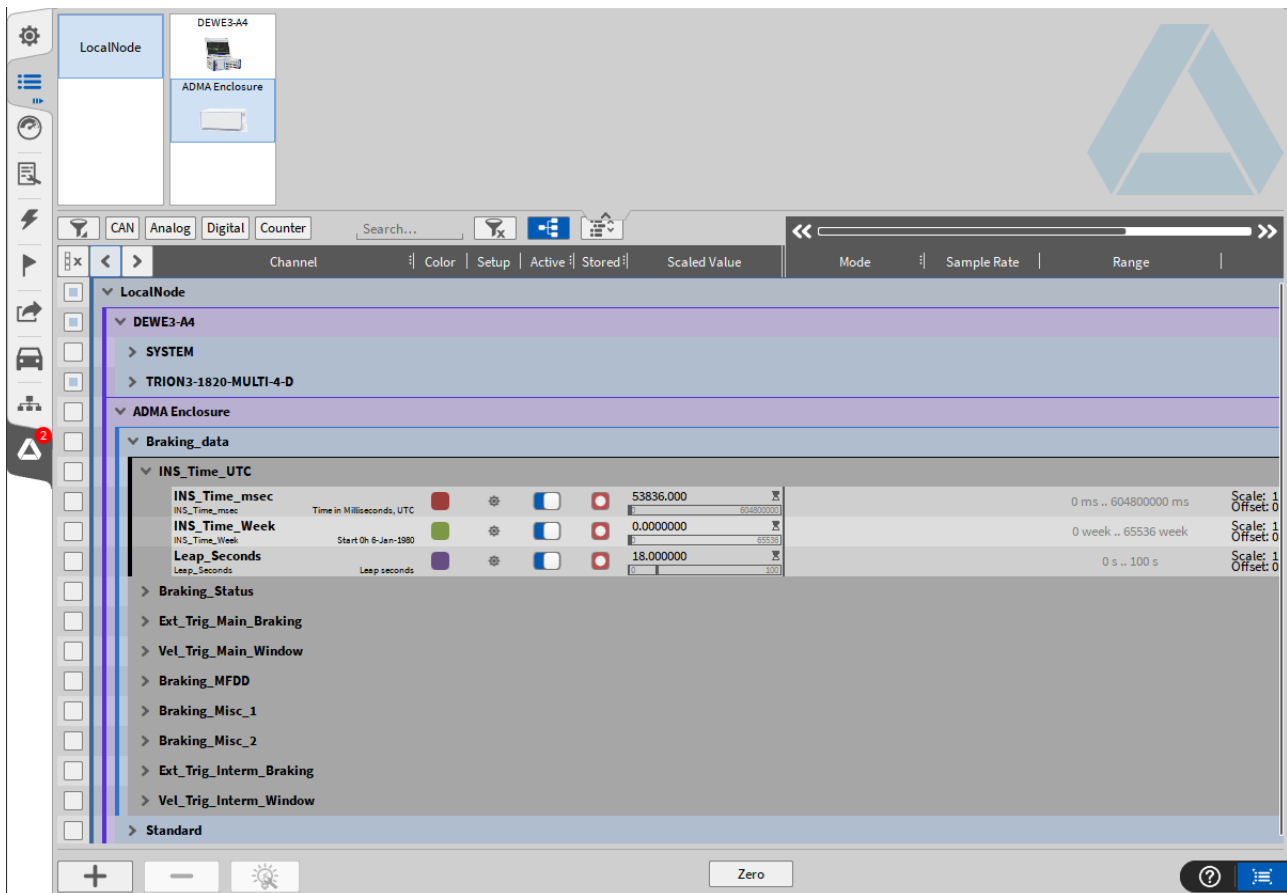

Figure 1-3: ADMA enclosures in the Channel List; 2 streams enabled, one standard, one braking data.

## 1.4 ADMA STREAM CONFIGURATION

The following ADMA stream settings are required for each activated ADMA stream:

- StreamX\_Enabled: Enable or disable the data acquisition via the individual ADMA stream here. Once activated, the stream with the corresponding channels will show up in the Channel List (see Figure 1-3). Per default, all channels from the stream are activated and stored.
- StreamX\_Name: Enter a user defined data stream name here
- StreamX\_Port: This is the destination port of the data stream as defined in the web-interface of the corresponding ADMA. The IP address is not required as the network addresses from all ADMAs and PCs must be within the same subnet range. The following output streams can be acquired:
- **ADMAnet** (in the ADMA Web-UI: Data → Ethernet data output)

Ethernet data output	
Data Format	ADMAnet
Data Format Version	v3.3.1
Destination IP	192.168.88.100
Destination Port	1021

Figure 1-4: ADMAnet data output - web interface settings

**NOTE: All data format versions v3.3.x are supported**

- **DELTA data** (in the ADMA Web-UI: Addons → DELTA data → DELTA data output)

DELTA data output	
ADMA interface	Ethernet1 ▾
Protocoll version	v7.0 ▾
Rate	100 Hz ▾
Destination IP	192.168.88.32 ip
Destination port	1026

Figure 1-5: ADMADelta data output - web interface settings

NOTE: Data format version v7.0 is supported

- **StreamX\_Channels:** Select between different predefined Channel stream list here. Depending on the application, only a sub-set of all ADMA output channels are necessary. Therefore, several predefined channel collections are available (A detailed list is available in section 5):
  - **ADMAnet Standard** (98 channels, default channel collection)  
Contains all important channels and data for POI1 (typ. vehicle center of gravity) and POI2 (typ. vehicle geometrical center).  
Typical use case: most ADAS tests.
  - **ADMAnet no BARO, EVEL, DUALANT** (265 channels)  
Contains all channels except channels from the ADMAs barometric sensor, external velocity sensors and dual-antenna data.  
Typical use case: when you want to be sure to get all relevant data from the ADMA.
  - **ADMAnet all POIs** (190 channels)  
Identical with channel collection “ADMAnet Standard”, but with all channels for all 8 POIs.  
Typical use case: AEB-VRU.
  - **ADMAnet Debug** (109 channels)  
All status channels and most important sensor channels, but no POI data.  
Typical use case: If a problem with the sensor is suspected.
  - **ADMAdelta Standard** (25 channels)  
All channels from the ADMA-DELTA stream.  
Typical use case: All DELTA-measurements when using the BirdsEye plugin.
  - **ADMAdelta Relative** (10 channels)  
The minimum set of ADMA-DELTA channels.  
Typical use case: When the BirdsEye plugin is not used.
- ADMA unit settings:

To support the ADMA IMU plugin in different countries, the physical units of all acquired ADMA channels can be predefined in ⑧ of Figure 1-2. These settings are valid for all channels of all activated ADMA streams.

The following options exists

- **UnitDistance:** The unit type of all channels containing distance information can be set to *centimeter [cm], meter [m], kilometer [km], inch [in], feet [ft], yards [yd] or miles [mi]*
- **UnitSpeed:** The unit type of all channels containing speed information can be set to *kilometers per hour  $\left[\frac{km}{h}\right]$ , meters per second  $\left[\frac{m}{s}\right]$  or miles per hout [mph]*
- **UnitAcceleration:** The unit type of all channels containing acceleration information can be set to *meter per second<sup>2</sup>  $\left[\frac{m}{s^2}\right]$ , acceleration of gravity [g] or milli – acceleration of gravity [mg]*

## 1.5 SYNCHRONIZATION OF ADMA AND ANALOG DATA

It is possible to synchronize analog / digital data acquired by DEWETRON TRION™ modules to the ADMA data streams. This can be done via the ADMAs’ PPS pulse that is generated with the GPS timing information. This PPS pulse can be output by the ADMA. The required ADMA settings are illustrated in Figure 1-6.

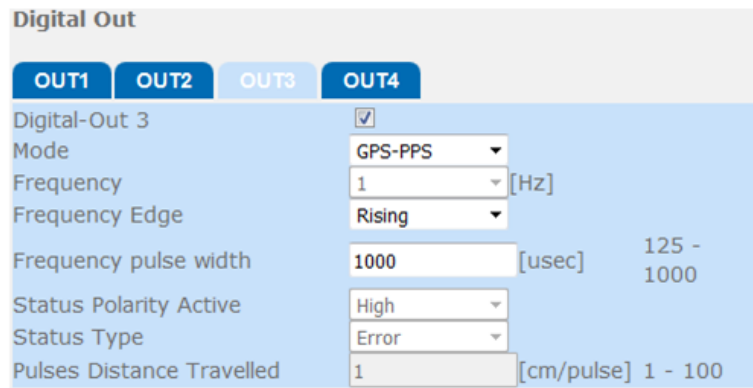

Figure 1-6: ADMA Signal-out settings for PPS-sync with TRION

For the timing synchronization, a TRION-BASE, TRION-TIMING or TRION-(V)GPS module is required which can receive and process a PPS pulse. Thus, the PPS pulse must be connected to one of these dedicated TRION™-modules.

After the connection is set up, go to the OXYGEN *Sync Setup* which can be found in the *System Settings* and set the *Input Sync Type* to *PPS* (see Figure 1-7):

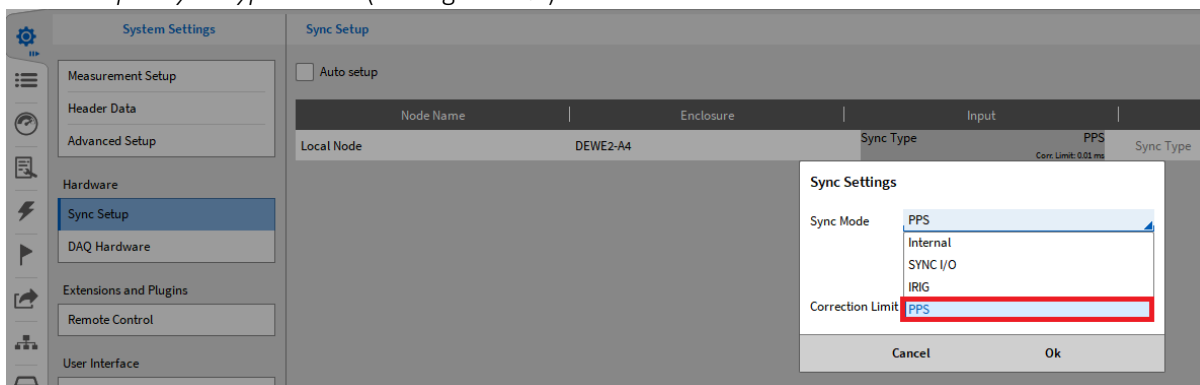

Figure 1-7: PPS Sync Settings

The *Sync Indicator* which can be found in the lower left side of the Action Bar will highlight green (see Figure 1-8) if a valid PPS pulse signal is received an highlight orange (see Figure 1-9) if the software is waiting for a valid sync signal. If no valid synchronization signal is received, the *Sync Indicator* will highlight red (se Figure 1-10).

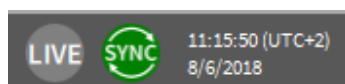

Figure 1-8: Valid PPS-sync signal is received

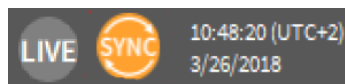

Figure 1-9: Software is waiting for a valid PPS signal

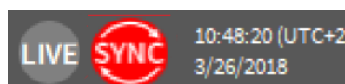

Figure 1-10: Invalid synchronization signal received

## 2 OXTS PLUGIN

The OxTS plugin allows for an acquisition of up to 6 UDP streams from up to 6 OxTS RT IMUs in OXYGEN.

Please note that the support of OsTX RTs is completely passive, thus OXYGEN can only acquire data from the RT. RTs cannot be configured via OXYGEN. The configuration must be done via the program *NAVconfig* of the RT.

The acquired data can be either SW-synchronized (i.e. two or more RTs are synchronized to each other, but analog data is asynchronous to RT data) or HW-synchronized (i.e. RT data is synchronized also to analog data).

To suit various applications, the plugin offers the acquisition of NCOM data streams (i.e. RTxxxx) or RCOM data streams (i.e. RT-Range).

The integrated unit-conversion allows for rescaling of the RTs output units to pre-defined units for distance, velocity and acceleration.

### 2.1 INSTALLATION

The OxTS plugin is automatically installed with every Oxygen R3.4 (December 2018) and above. Once installed, the plugin needs to be licensed (if not done by DEWETRON factory already) and activated.

### 2.2 PLUGIN LICENSING

The plugin license can be updated under the System Information tab (see Figure 2-1). This requires a \*.lic-file provided by DEWETRON. A license update requires a restart of Oxygen.

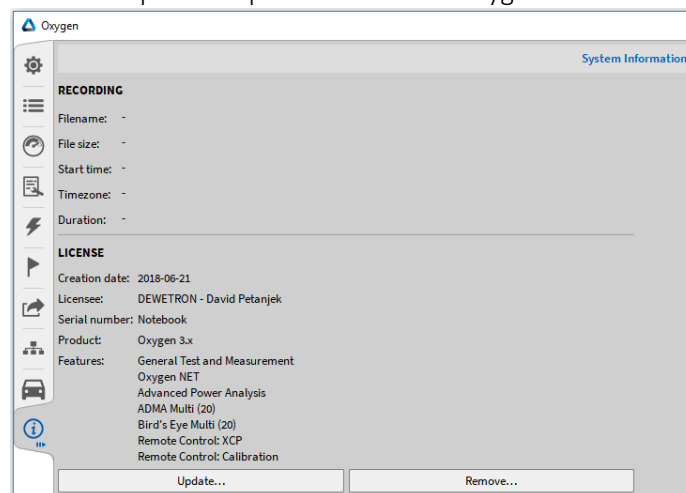

Figure 2-1: Updating the OXYGEN-license

## 2.3 OVERVIEW

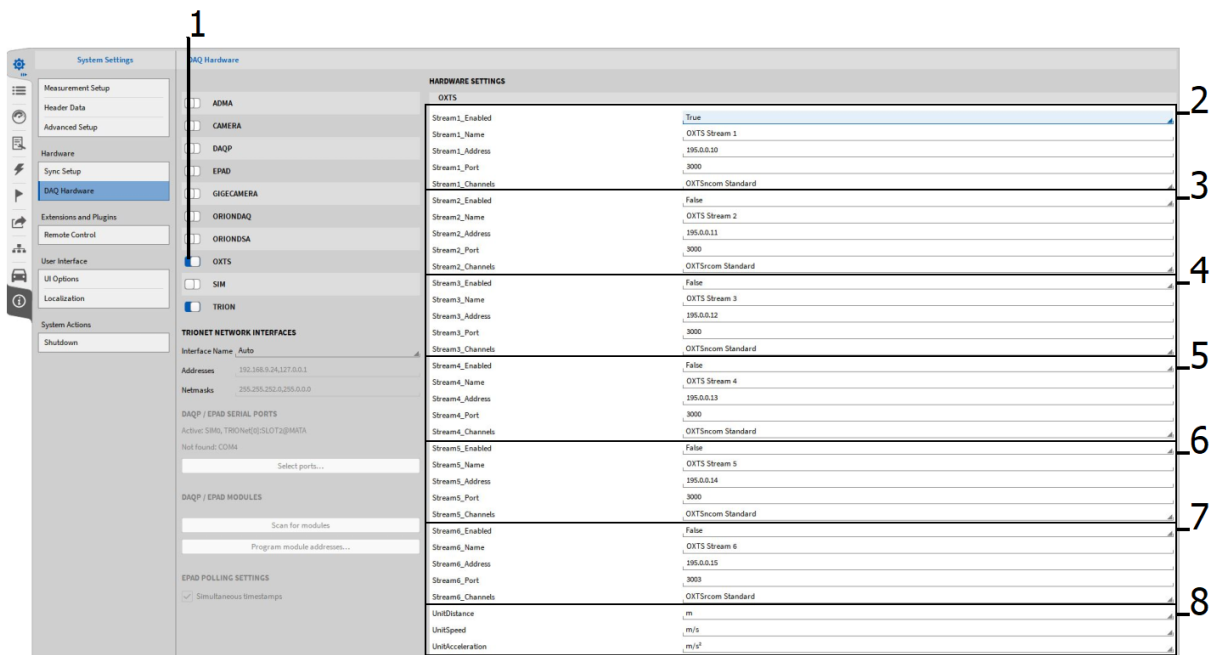

Figure 2-2: DAQ-hardware setup - RT settings

1	Enable RT hardware	Enables/Disable data acquisition from RTs
2	RT Stream 1 settings	Settings for data stream 1
3	RT Stream 2 settings	Settings for data stream 2
4	RT Stream 3 settings	Settings for data stream 3
5	RT Stream 4 settings	Settings for data stream 4
6	RT Stream 5 settings	Settings for data stream 5
7	RT Stream 6 settings	Settings for data stream 6
8	Unit settings	Settings for the unit conversion

Table 2-1: DAQ hardware setup - RT settings

To enable the data acquisition by the RT, go to the *DAQ Hardware* setup that can be found in the *System Settings* and enable *OxTS* hardware (see ① in Figure 2-2). A software restart is required after enabling DAQ hardware.

Up to 6 UDP streams can be acquired by OXYGEN simultaneously. The settings for the single RTs streams can be found in ②, ③, ④, ⑤, ⑥ and ⑦ of Figure 2-2. For details, please refer to section 2.4.

The desired unit of the data channels acquired by the RT can be selected in ⑧ of Figure 2-2. For details, please refer to section 2.4.

**Remark:** Please note that the settings in the DAQ hardware setup are not stored to an OXYGEN setup (dms) file. These settings are only stored to the registry. The advantage is that the settings must only be done once on the same PC and may remain untouched afterwards. But be aware that the settings must be done on another PC if the dms-setup file is copied and loaded there!

The single data channels acquired by the individual stream can be found in the channel list if the data stream is enabled. An own RT enclosure will show up in the Channel List topology containing all activated RT streams containing the individual channels (see Figure 2-3).

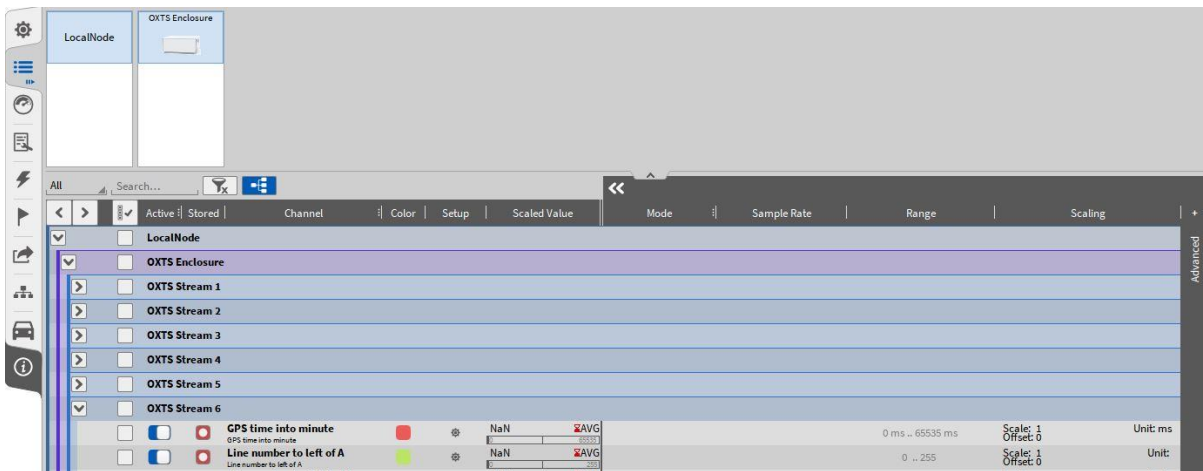

Figure 2-3: RT enclosures in the Channel List; 6 streams enabled

## 2.4 RT STREAM CONFIGURATION

The following RT stream settings are required for each activated RT stream:

- **StreamX\_Enabled:** Enable or disable the data acquisition via the individual RT stream here. Once activated, the stream with the corresponding channels will show up in the Channel List (see Figure 1-3). Per default, all channels from the stream are activated and stored.
- **StreamX\_Name:** Enter a user defined data stream name here
- **StreamX\_Address:** This is the IP address of the RT. The IP address can be configured via the NAVConfig. For details, please refer to the RT User Manual.
- **StreamX\_Port:** This is the destination port of the data stream. Per default, the Port is set to 3000 and does not need to be changed.
- **StreamX\_Channels:** Depending on the connected RT IMU, different channel data streams can be selected here.
  - If a **RT1003/2000/3000/4000 or similar** is connected, the **OxTSncom Standard** stream must be selected. For details, please refer to the NCOM Description Manual.
  - If a **RT-Range or similar** is connected, the **OxTSrcom Standard** stream must be selected. For details, please refer to the RT-Range Manual.
- **RT unit settings**

To support the OxTS IMU plugin in different countries, the physical units of all acquired RT channels can be predefined in ⑧ of Figure 2-2. These settings are valid for all channels of all activated RT streams.

The following options exist:

- **UnitDistance:** The unit type of all channels containing distance information can be set to *centimeter [cm], meter [m], kilometer [km], inch [in], feet [ft], yards [yd] or miles [mi]*
- **UnitSpeed:** The unit type of all channels containing speed information can be set to *kilometers per hour  $\left[\frac{km}{h}\right]$ , meters per second  $\left[\frac{m}{s}\right]$  or miles per hour [mph]*
- **UnitAcceleration:** The unit type of all channels containing acceleration information can be set to *meter per second<sup>2</sup>  $\left[\frac{m}{s^2}\right]$ , acceleration of gravity [g] or milli – acceleration of gravity [mg]*

## 2.5 TROUBLESHOOTING

If no RT data is received by OXYGEN, please take care of the following points:

- Make sure that the *OxTS Device IP address* in *OXYGEN Measurement Settings* → *DAQ Hardware* is set to the IP address of the RT unit and the *UDP port* is set to 3000 (see Figure 2-4). The IP address of a RT unit is the in the 195.0.0.xxx range.

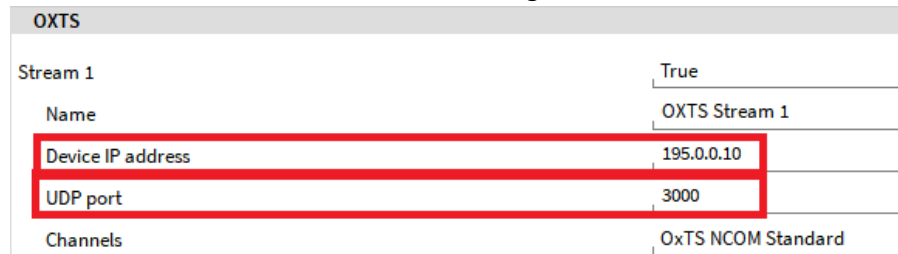

Figure 2-4: OxTS device IP settings

- Make sure, that the IP address of the IP port the RT unit is connected to is set to a static IP address that is in the same subnet range as the IP address of the RT unit itself (normally 195.0.0.xxx) and not an automatic IP address.
- Make sure that OxTS is added to the Firewall exceptions (see Figure 2-5):

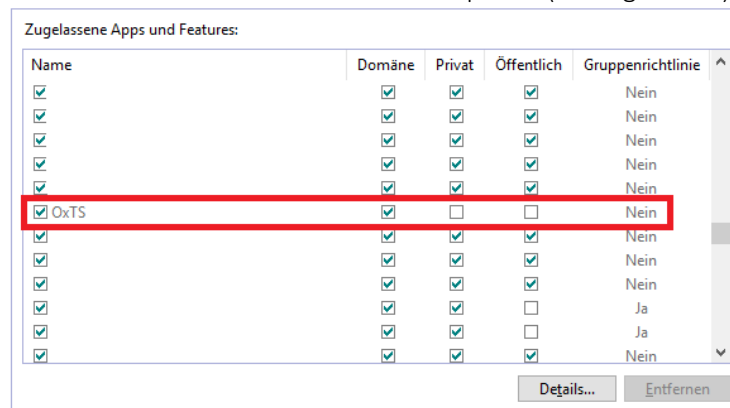

Figure 2-5: Firewall settings for OxTS

- If the *OxTS NAVsuite x.x* software is installed to the PC, an IP address filter which is named *NAVstart\_beta* is installed per default and added to the *Autostart* menu. This filter must be deactivated when RT data shall be received by OXYGEN. To do so, open the *Task Manager* and go to the *Autostart* tab. Search for *NAVstart\_beta* and deactivate this process (see Figure 2-6).

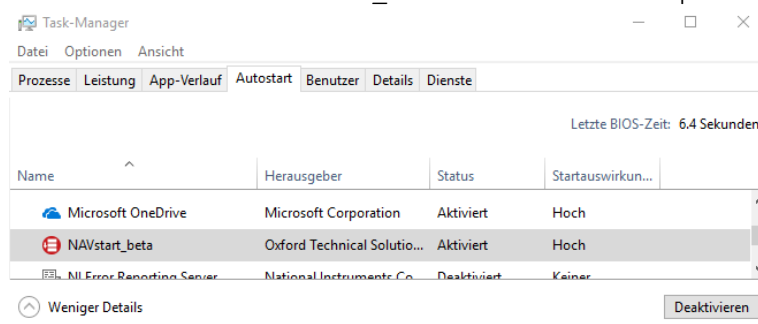

Figure 2-6: Deactivation of NAVstart\_beta

## 2.6 SYNCHRONIZATION OF RT AND ANALOG DATA

It is possible to synchronize analog / digital data acquired by DEWETRON TRION™ modules to the RT data streams. This can be done via the RTs' PPS pulse that is generated with the GPS timing information. This PPS pulse can be output by the RT.

**Remark: The falling edge of the pulse is the exact transition from one second to the next in GPS time.**

For the timing synchronization, a TRION-TIMING V3 module is required which can receive and process a PPS pulse sync'd to the falling edge.

**Remark: Other TRION-modules than the TRION-TIMING V3 can't be used as they are only able to process PPS pulses sync'd to the rising edge!**

After the connection is set up, go to the OXYGEN *Sync Setup* which can be found in the *System Settings*. Set the *Input Sync Type* to *PPS* and the *Inverted Input* to *True* (see Figure 2-7). This ensures the correct data synchronization to the falling edge of the PPS pulse:

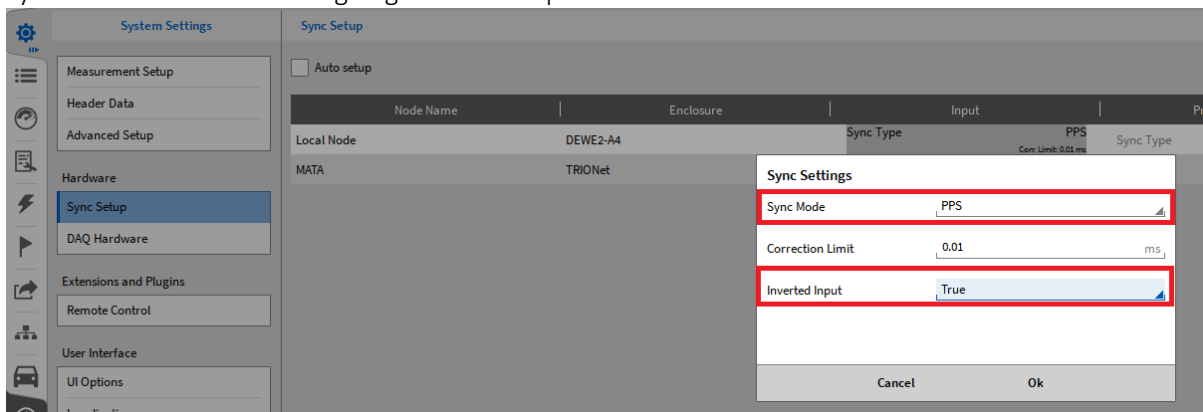

Figure 2-7: PPS Sync Settings

The *Sync Indicator* which can be found in the lower left side of the Action Bar will highlight green (see Figure 2-8) if a valid PPS pulse signal is received an highlight orange (see Figure 2-9) if the software is waiting for a valid sync signal. If no valid synchronization signal is received, the *Sync Indicator* will highlight red (see Figure 2-10).

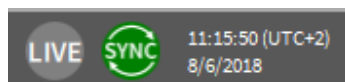

Figure 2-8: Valid PPS-sync signal is received

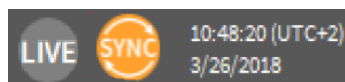

Figure 2-9: Software is waiting for a valid PPS signal

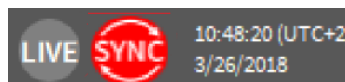

Figure 2-10: Invalid synchronization signal received

# 3 OXYGEN AUTOMOTIVE PLUGIN – OVERVIEW

## 3.1 INSTALLATION

The OXYGEN Automotive plugin is automatically installed with every Oxygen R3.2 (June 2018) and above. Once installed, the plugin needs to be licensed (if not done by DEWETRON factory already) and activated.

## 3.2 PLUGIN LICENSING

The plugin license can be updated under the System Information tab (see Figure 3-1). This requires a \*.lic-file provided by DEWETRON. A license update requires a restart of Oxygen.

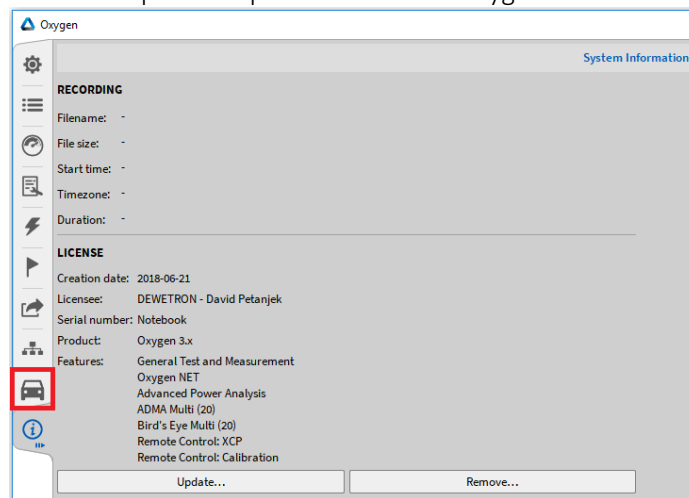

Figure 3-1: Updating the OXYGEN-license

After restarting OXYGEN, the OXYGEN Automotive plugin will be available in the Menu List (marked red in Figure 3-1) and can be enlarged to the full screen with a double click on its icon.

### 3.3 SETUP MENU

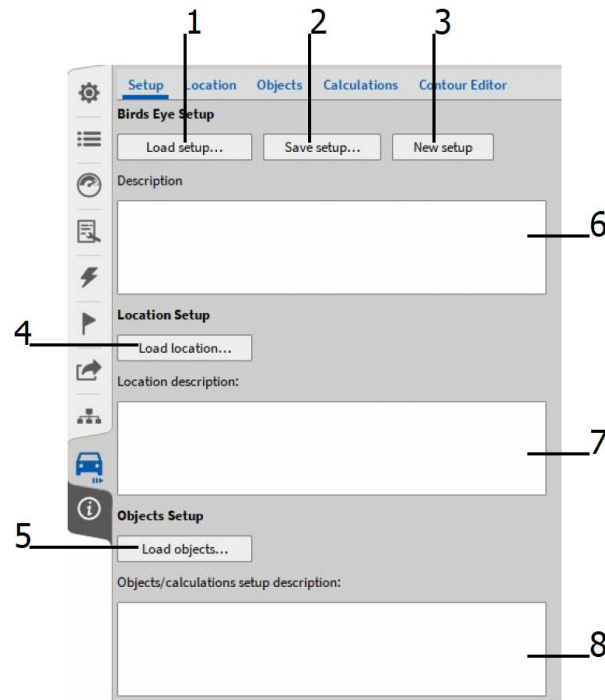

Figure 3-2: Setup tab - Overview

1	<i>Load setup...</i> button	Load an existing Automotive plugin setup (does not affect the OXYGEN dms- setupfile). The file extension is *.bie
2	<i>Save setup...</i> button	Save the current setup to a *.bie file (does not affect the OXYGEN dms- setupfile)
3	<i>New setup</i> button	Create a new and blank automotive setup (does not affect the OXYGEN dms-setupfile)
4	<i>Load location...</i> button	Load only the settings done on the <i>Location</i> tab from an existing *.bie-file
5	<i>Load objects...</i> button	Load only the settings done the <i>Objects</i> and <i>Calculation</i> tab from an existing *.bie-file
6	Space for individual and general setup description and comments	
7	Space for individual and location specific description and comments	
8	Space for individual and objects/calculation specific description and comments	

Table 3-1: Setup tab – Overview

### 3.4 LOCATION MENU

#### 3.4.1 OVERVIEW

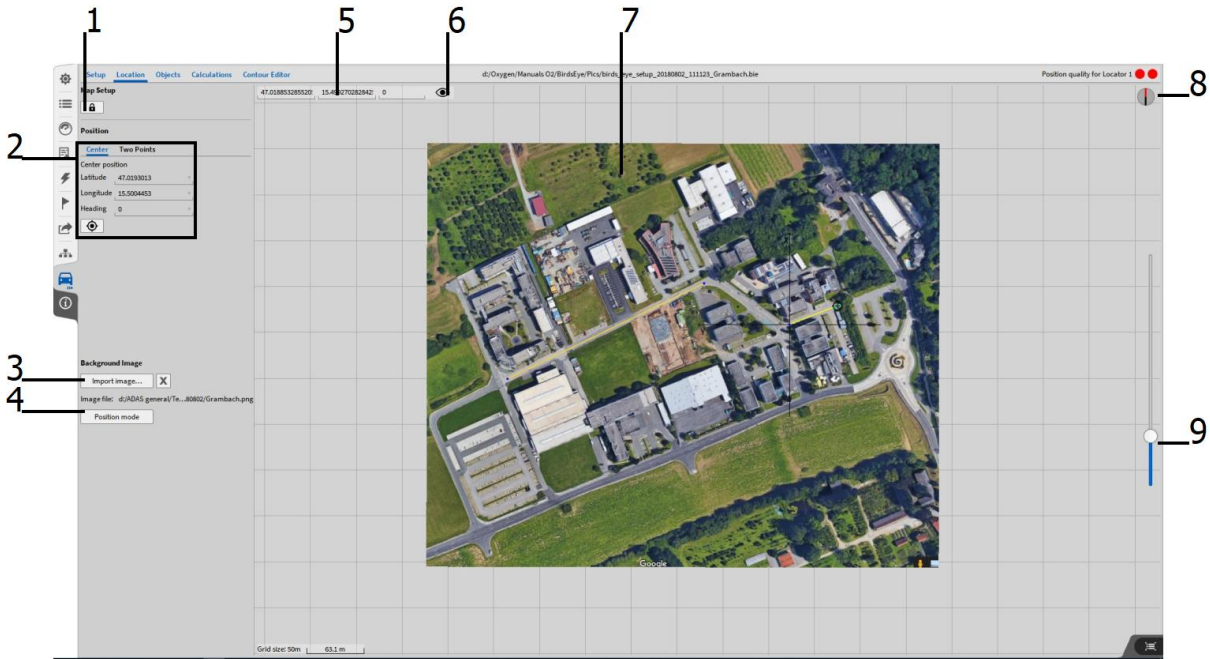

Figure 3-3: Location tab – Overview

1	<i>Map Lock</i> button	This button locks the entire functionality on this setup tab to avoid unintentional settings. Per default, the Map lock button is activated.
2	<i>Position</i> setup	The origin and the heading of the coordinate system can be defined here. For details, please refer to section 3.4.3
3	<i>Import Image</i> button	A background image to illustrate the test environment can be selected and imported here
4	<i>Position / Image mode</i> menu	The button toggles between the position mode to define the origin and the heading of the coordinate system and the image mode to define and assign the reference points of the background images with absolute GNSS coordinates. For details, please refer to section 3.4.2.
5	<i>Current</i> coordinates	The coordinates of the current center of the preview (7) is displayed here
6	<i>Eye</i> button	A click on this button zooms the preview automatically to a zoom factor which displays all created Objects in the preview window. For Objects definition, please refer to section 3.5.
7	<i>Image Preview</i>	Preview of the actual image, (test environment) and the created objects; Can be moved while keeping the left mouse button pressed
8	<i>Rotate</i> button	The heading of the preview can be changed here
9	<i>Zoom</i> bar	The zoom factor of the preview can be adjusted manually here; Zoom can be applied with the mouse wheel as well

Table 3-2: Location tab – Overview

#### 3.4.2 IMPORTING AND POSITIONING OF BACKGROUND IMAGES

To illustrate the test environment, a satellite image can be imported. I.e., the satellite image can be a screenshot from Google Maps. For positioning the image correctly (to ensure a correct mapping to other objects with assigned GNSS coordinates), the user must know the absolute GNSS coordinates of two points displayed on this image. The GNSS coordinates can be acquired from Google Maps, or similar apps.

**Remark: OXYGEN Automotive requires GNSS coordinates in decimal degree!**

To ensure an ideal fitting of the image, both GNSS coordinates must be distributed in a diagonal across the image with a maximum possible distance. Otherwise, the earth curvature cannot be respected correctly and the image is distorted. Some good and bad examples for selecting GNSS coordinates on the background image can be seen in the following Figure 3-4.



Figure 3-4: Good (left) and bad examples (middle, right) for selecting GNSS coordinates on the background image

If the background image fits to the map can be checked in the BirdsEye instrument (please refer to section 4) An online map from OpenStreetMap© is displayed by the instrument when the PC has a valid internet connection. The background image is displayed in front of the OpenStreetMap© there and the opacity of the image can be changed. This functionality can be used to check the fitting of the background image.

To import and position a background image, proceed the following steps:

- A user dialog for the image import can be opened with a click on the Import Image button (see ③ in Figure 3-3). Make sure that the Map setup is unlocked (see ① in Table 3-2)!
- After importing the image, press the Position / Image mode button (see ④ in Figure 3-2) to assign and position the two known GNSS points on the background image.
- Two red cursors will be displayed in the Image preview which are marked with red arrows in Figure 3-5



Figure 3-5: Cursors to assign the GDP coordinates to the background image

- Move both cursors to the reference positions the GNSS coordinates are known via drag and drop with the left mouse button
- The dialog box to enter the GNSS coordinates can be opened with a left click on the respective cursor (see Figure 3-6). Latitude and Longitude can be entered there. In addition, the actual coordinates of a Locator object (please refer to section 3.5.4) can be assigned to the point by a click on the Locator button marked in red in Figure 3-6. Please note that the Locator button is only visible if a Locator object is already defined. The X and Y position displayed below the Locator button mark the actual Pixel position of the red cursor in the background image. The cursor can be moved as well by entering other X and Y pixel coordinates here.

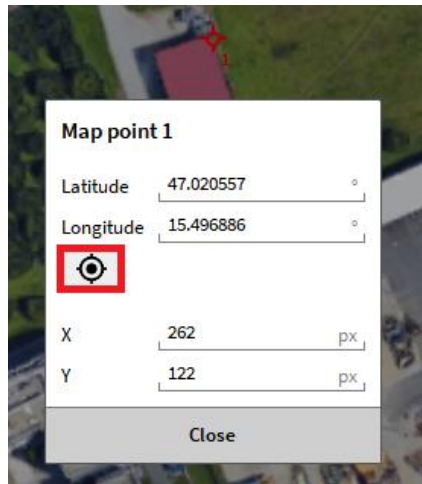

Figure 3-6: Map point menu

- This procedure must be repeated for the second GNSS point
- After repeating the procedure for the second GNSS point, the map is positioned and adjusted correctly
- The image positioning menu can be left by clicking the Position / Image mode button (see ④ in Figure 3-3) again

### 3.4.3 COORDINATE SYSTEM DEFINITION

Next, the origin of the coordinate system must be defined. This can be done in two ways:

- Via one reference point and its corresponding Latitude, Longitude and a Heading
- Via two reference points and their corresponding Latitude, Longitude and the distance between both points

#### 3.4.3.1 Coordinate System Definition via one Point

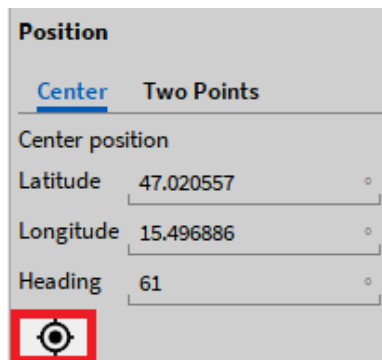

Figure 3-7: Position dialog for one reference point

To define the origin of the coordinate system via one point, Latitude and Longitude of this point must be known. This point is used as origin for the coordinate system. The direction the X-Axis points can be defined

via the Heading from 0...360°. If a Locator object (please refer to section 3.5.4) exists, the actual Latitude, Longitude and Heading of the Locator object can be used as coordinate system origin with a click on the *Locator* button marked in red in Figure 3-7.

The advantage of this method is that only one point is required for the coordinate system definition. The disadvantage thereby is to define the Heading X-Axis points to accurately. To define the Heading of the X-Axis more accurately, the second possibility of the coordinate system definition via two points can be used.

### 3.4.3.2 Coordinate System Definition via two Points



Position	
Center	<u>Two Points</u>
<b>Point 1</b>	
Latitude	50.288179 °
Longitude	11.864665 °
	
X	0 m
Y	0 m
<b>Point 2</b>	
Latitude	50.287833 °
Longitude	11.854968 °
	
X	688.87 m
Y	0 m

Figure 3-8: Position dialog for two reference points

To define the origin and the Heading of the coordinate system via two points, the Latitude and Longitude of both points and the distance of both points in X- and Y-direction must be known. To define the origin of the coordinate system, enter Latitude and Longitude of this point at Point 1 and enter X=0 and Y=0 below (see Figure 3-8). This point is the origin now. It is also possible to use a Locator object again if it is already defined and copy its actual Latitude and Longitude via a click on the *Locator* button (marked in red in Figure 3-8). Next, enter the Latitude and Longitude of the second point (or copy it from a Locator object) and enter distance between both points in X- and Y-direction to align the Heading correctly. If only the distance in X-direction is entered, the X-Axis will point directly from Point 1 to Point 2. It is also recommended to use two points which are on the X-axis for this procedure as this is the easiest way to define the Heading.

The advantage of this method is that the Heading can be defined very accurately and the disadvantage is that the coordinates of two points must be known.

### 3.5 OBJECTS MENU

#### 3.5.1 OVERVIEW

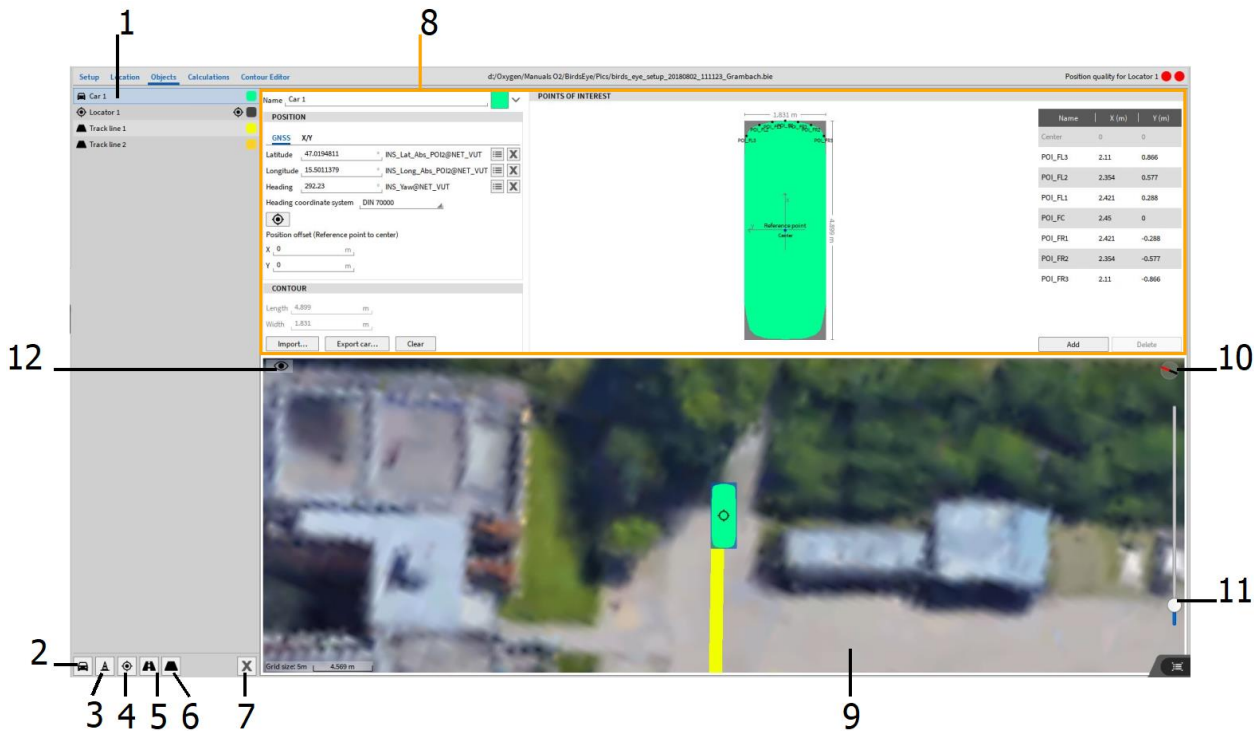

Figure 3-9: Objects tab - Overview

1	<i>Objects list</i>	The created objects are listed here and can be selected to change their settings
2	<i>Add vehicle button</i>	Adds a vehicle (moving object) to the setup (for details, please refer to section 3.5.2)
3	<i>Add cone button</i>	Adds a cone (position object) to the setup (for details, please refer to section n3.5.3)
4	<i>Add Locator button</i>	Adds a Locator object to the setup (for details, please refer to section 3.5.4)
5	<i>Add KML track button</i>	Adds a kml-trackfile to the setup (for details, please refer to section 3.5.5)
6	<i>Add track button</i>	Adds a road /track to the setup (for details, please refer to section 0)
7	<i>Delete Object button</i>	Deletes the objects that is currently selected in the <i>Objects</i> list
8	<i>Objects settings menu</i>	The settings of the object that is currently selected in the <i>Objects</i> List can be edited here
9	<i>Preview window</i>	Preview of the created objects and the loaded image; Can be moved while keeping the left mouse button pressed
10	<i>Rotate button</i>	The heading of the preview can be changed here
11	<i>Zoom bar</i>	The zoom factor of the preview can be adjusted manually here; Zoom can be applied with the mouse wheel as well
12	<i>Eye button</i>	A click on this button zooms the preview automatically to a zoom factor which displays all created Objects in the preview window.

Table 3-3: Objects tab - Overview

#### 3.5.2 VEHICLES (MOVING OBJECTS)

A vehicle / moving objects object can be added to the setup by clicking on the *Add vehicle* button (see ② in Figure 3-9). The main characteristic of the vehicle object the shape of an object that was created with the Contour Editor (please refer to section 3.7) can be loaded and assigned to the vehicle object.

During AEB tests, vehicle objects can be used to define the shape of VUTs (Vehicle Under Test) GVTs (Global Vehicle Target), EBTs (European Bicycle Target), EPTas (European Pedestrian Target adult) or EPTcs (European Pedestrian Target child).

### 3.5.2.1 Vehicle Object Menu

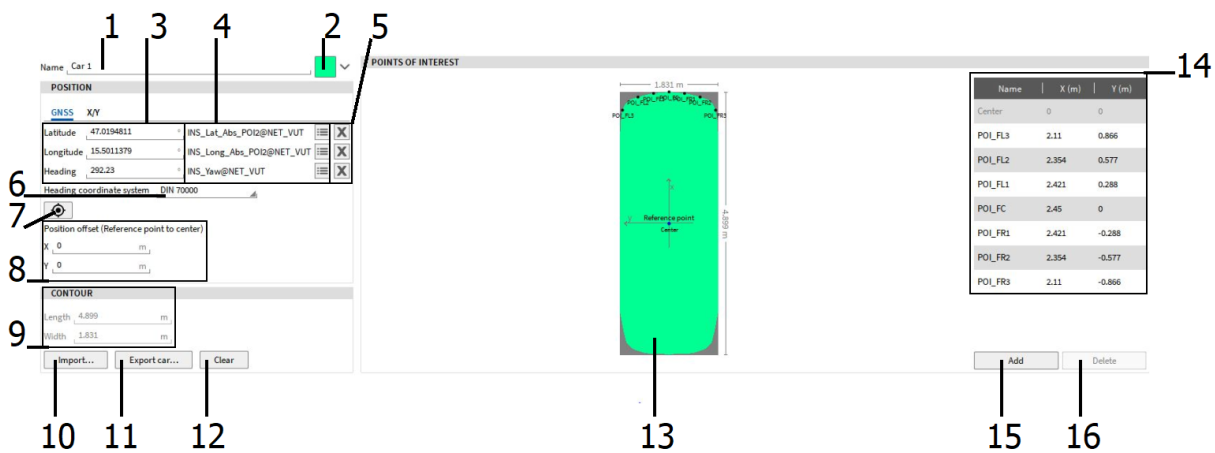

Figure 3-10: Vehicles object menu – Overview

1	Object name	Edit the objects' name here
2	Object color	Edit the objects' color here
3	Object GNSS coordinates	Enter static GNSS coordinates here / Displays the actual GNSS coordinates if IMU channels are assigned
4	Assign IMU channels button	Select IMU channels from a list here
5	Clear assigned IMU channels	Delete selected IMU channels here
6	Coordinate system selection	Swap DIN 70000 and SAE coordinate system definition (for details, please refer to section 3.5.6.3)
7	Copy Locator coordinates button	Copies the actual position of a <i>Locator</i> object to the vehicle. For details about the <i>Locator</i> object, please refer to section 3.5.4
8	Position offset definition	Define the offset of the reference position from the geometrical center from the object here. Per default, the offset is X=0 and Y=0
9	Contour dimension definition	Define the length and the width of the object here. This is obsolete if a contour created with the Contour Editor is imported here.
10	Import... button	Opens an import dialog to select a contour that was created with the Contour Editor
11	Export car... button	Exports the vehicle to a xml-file.
12	Clear button	Clears the actual contour settings
13	Preview window	Preview of the vehicle contour
14	POI table	Displays the created POIs, i.e. if they were added with the Contour Editor
15	Add button	Adds additional POIs
16	Delete button	Deletes the POI that is selected in the POI table

Table 3-4: Vehicles object menu – Overview

### 3.5.2.2 Positioning of a vehicle

Three different possibilities to position a vehicle in the setup exist:

- Via static GNSS coordinates (static vehicle)
- If the vehicle is static, the desired Latitude, Longitude and Heading can be entered manually in the GNSS positioning menu (see ③ in Figure 3-10) if the absolute GNSS coordinates are known. The actual position of a Locator object may also be assigned to a static vehicle by clicking on the Locator button (see ⑦ in Figure 3-10).
- Via GNSS coordinates acquired by an IMU (moving vehicle)
- If the object is moving, the Latitude, Longitude and Heading information acquired by an IMU can be assigned by clicking on the Assign IMU channels button (see ④ in Figure 3-10). After clicking on the button, a popup menu (see Figure 3-11) will appear where the user can select the desired channel. This procedure must be repeated for the Latitude, Longitude and Heading channel separately. Mathematical channels may be applied, too. The applied channel is displayed left to the Assign IMU channel button.

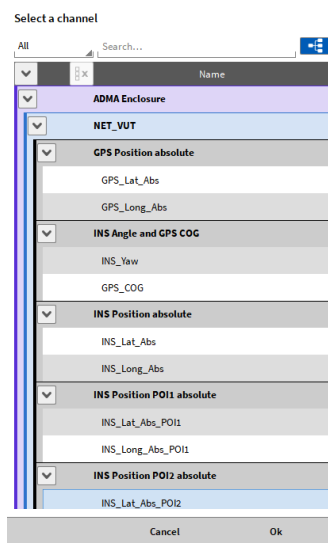

Figure 3-11: IMU channel selection popup menu

- Via X/Y-coordinates referred to the defined coordinate system (static vehicle)
- Instead of positioning static vehicles according to GNSS coordinates, it is also possible to position a static vehicle according to X/Y-coordinates that refer to the coordinate system whose origin was defined in the Location setup (see section 3.4.3). Therefore, the user can change to the Position X/Y menu and enter the X-and Y-Coordinate as well as the Heading information and the Heading coordinate system there (see Figure 3-12).

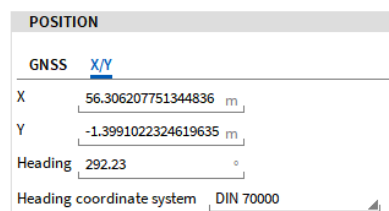

Figure 3-12: Vehicle positioning via X/Y-coordinates

**Hint:** If the position is defined via X/Y coordinates, relative to the main cartesian coordinate system, moving its origin or rotating it also moves or rotates those objects.

### 3.5.3 CONES (POSITION OBJECTS)

A Cone / Position object can be added to the setup by clicking on the *Add cone* button (see ③ in Figure 3-9). A cone can be used to mark static positions, like theoretical crashpoints during CCRb (Car-to-Car-Rear brake) tests, to represent marking spots in the measurement setup or to mark moving positions, like the tow-bar of a car.

During AEB tests, vehicle objects can be used to define VUTs (Vehicle Under Test) GVTs (Global Vehicle Target), EBTs (European Bicycle Target), EPTas (European Pedestrian Target adult) or EPTcs (European Pedestrian Target child).

#### 3.5.3.1 Cone Object Menu

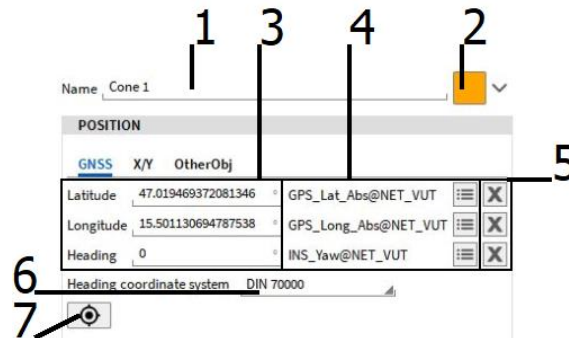

Figure 3-13: Cones object menu – Overview

1	Object name	Edit the objects' name here
2	Object color	Edit the objects' color here
3	Object GNSS coordinates	Enter static GNSS coordinates here / Displays the actual GNSS coordinates if IMU channels are assigned
4	<i>Assign IMU channels</i> button	Select IMU channels from a list here
5	Clear assigned IMU channels	Delete selected IMU channels here
6	<i>Coordinate system</i> selection	Swap DIN 70000 and SAE coordinate system definition (for details, please refer to section 3.5.6.3)
7	<i>Copy Locator coordinates</i> button	Copies the actual position of a <i>Locator</i> object to the vehicle. For details about the <i>Locator</i> object, please refer to section 3.5.4

Table 3-5: Cones object menu – Overview

#### 3.5.3.2 Positioning of a Cone

Four different possibilities to position a cone in the setup exist:

- Via static GNSS coordinates (static cone)
- If the cone is static, the desired Latitude, Longitude and Heading can be entered manually in the GNSS positioning menu (see ③ in Figure 3-13) if the absolute GNSS coordinates are known. The actual position of a *Locator* object may also be assigned to a static cone by clicking on the *Locator* button (see ⑦ in Figure 3-13).
- Via GNSS coordinates acquired by an IMU (moving cone)
- If the cone is moving, the Latitude, Longitude and Heading information acquired by an IMU can be assigned by clicking on the *Assign IMU channels* button (see ④ in Figure 3-13). After clicking on the button, a popup menu (see Figure 3-14) will appear where the user can select the desired channel. This procedure must be repeated for the Latitude, Longitude and Heading channel separately. Mathematical channels may be applied, too. The applied channel is displayed left to the *Assign IMU channel* button.

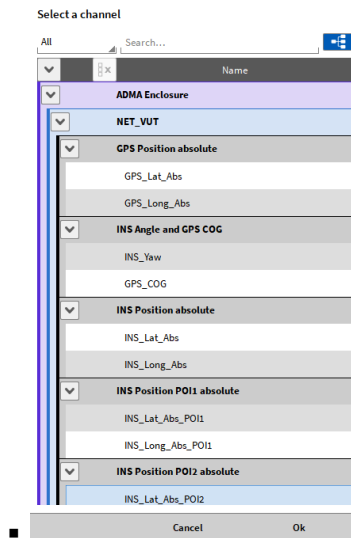

Figure 3-14: IMU channel selection popup menu

- Via X/Y-coordinates referred to the defined coordinate system (static cone)
- Instead of positioning static cones according to GNSS coordinates, it is also possible to position a static cone according to X/Y-coordinates that refer to the coordinate system whose origin was defined in the Location setup (see section 3.4.3). Therefore, the user can change to the Position X/Y menu and enter the X-and Y-Coordinate as well as the Heading information and the Heading coordinate system there (see Figure 3-15)

Figure 3-15: Cone positioning via X/Y-coordinates

- Via X/Y-coordinates following another object
- The cone may also follow another object, like a car if the cone represents a tow-bar. To do so, go to the Position – OtherObj menu (see Figure 3-16) and select the object to be followed in the Other Object selection. The offset to the geometrical mean of the selected can be entered in the X- and Y- column. It is also possible to assign the cone to a POI that was defined for the Object to be followed. By clicking on the Copy POI location button, a popup menu to select the desired POI will open. In this case, the Cone will match with the selected POI.

Figure 3-16: Cone following another object

**Hint:** If the position is defined via X/Y coordinates, relative to the main cartesian coordinate system, moving its origin or rotating it also moves or rotates those objects.

### 3.5.4 LOCATORS

A Locator object can be added to the setup by clicking on the *Add Locator* button (see ④ in Figure 3-9). A Locator can be used to assign the GNSS position of the Locator itself to other objects by clicking on the Locator button in other menus (i.e. ⑦ in Figure 3-13). To use this functionality, Latitude, Longitude and Heading channels of an IMU must be assigned to the Locator. The Locator may also be linked to the POI of another Object (like the geometrical center of a car).

#### 3.5.4.1 Locator Object Menu

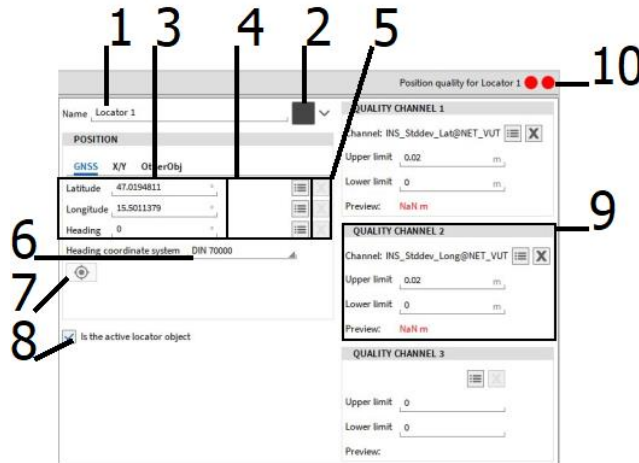

Figure 3-17: Locator object menu – Overview

1	Object name	Edit the objects' name here
2	Object color	Edit the objects' color here
3	Object GNSS coordinates	Enter static GNSS coordinates here / Displays the actual GNSS coordinates if IMU channels are assigned
4	<i>Assign IMU channels</i> button	Select IMU channels from a list here
5	<i>Clear assigned IMU channels</i> button	Delete selected IMU channels here
6	<i>Coordinate system</i> selection	Swap DIN 70000 and SAE coordinate system definition (for details, please refer to section 3.5.6.3)
7	<i>Copy Locator coordinates</i> button	Copies the actual position of a <i>Locator</i> object to the vehicle. For details about the <i>Locator</i> object, please refer to section 3.5.4
8	<i>Active Locator</i> selection	As several <i>Locators</i> may be created, the active one the actual position shall be copied to another object may be selected here
9	<i>Position Quality channel</i> menu	All in all, three channels to surveille the current quality of the GNSS signal can be selected. For details, please refer to section 3.5.4.3
10	<i>Position quality channel</i> preview	Preview of the current quality of the GNSS signal

Table 3-6: Locator object menu – Overview

#### 3.5.4.2 Positioning of a Locator

Four different possibilities to position a Locator in the setup exist:

- Via static GNSS coordinates (static Locator)
- If the Locator is static, the desired Latitude, Longitude and Heading can be entered manually in the GNSS positioning menu (see ③ in Figure 3-15) if the absolute GNSS coordinates are known.
- Via GNSS coordinates acquired by an IMU (moving Locator)
- If the Locator is moving, the Latitude, Longitude and Heading information acquired by an IMU can be assigned by clicking on the Assign IMU channels button (see ④ in Figure 3-15). After clicking on the button, a popup menu (see Figure 3-18) will appear where the user can select the desired channel. This

procedure must be repeated for the Latitude, Longitude and Heading channel separately. Mathematical channels may be applied, too. The applied channel is displayed left to the Assign IMU channel button.

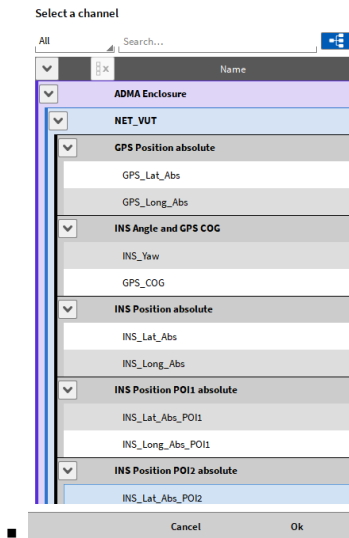

Figure 3-18: IMU channel selection popup menu

- Via X/Y-coordinates referred to the defined coordinate system (static Locator)
- Instead of positioning static Locators according to GNSS coordinates, it is also possible to position a static Locator according to X/Y-coordinates that refer to the coordinate system whose origin was defined in the Location setup (see section 3.4.3). Therefore, the user can change to the Position X/Y menu and enter the X-and Y-Coordinate as well as the Heading information and the Heading coordinate system there (see Figure 3-19)

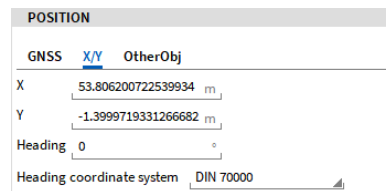

Figure 3-19: Locator positioning via X/Y-coordinates

- Via X/Y-coordinates following another object
- A POI of another object may also be used as Locator. To do so, go to the Position – OtherObj menu (see Figure 3-20) and select the object to be followed in the Other Object selection. The offset to the geometrical mean of the selected can be entered in the X- and Y-column. It is also possible to assign the Locator to a POI that was defined for the Object to be followed. By clicking on the Copy POI location button, a popup menu to select the desired POI will open. In this case, the Locator will match with the selected POI.

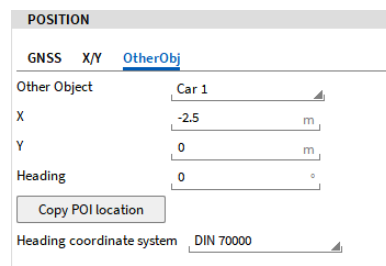
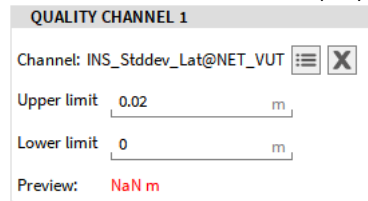

Figure 3-20: Locator following another object

**Hint:** If the position is defined via X/Y coordinates, relative to the main cartesian coordinate system, moving its origin or rotating it also moves or rotates those objects.

**3.5.4.3 GNSS signal quality surveillance**

It is possible to use signal quality channels acquired by an IMU to surveille the quality of the position signal (see Figure 3-21). The channel can be selected the channel List and a lower and an upper boundary for the signal quality can be entered. The actual channel value will be displayed in the *Preview* column.



**Figure 3-21: Locator Quality Channel menu**

Within the whole OXYGEN Automotive setup, the signal quality indicators (see ⑩ in Figure 3-17) in the upper right corner will be visible. During position assignment to other objects using an indicator, the user receives information about the current signal quality. If the actual signal is within the quality range defined in the Quality channel setup, the indicator will highlight green and red, if the current signal quality is out of the defined quality range.

Up to three quality channels can be defined. A separate indicator is defined for each quality channel.

**3.5.5 KML TRACKS**

KML tracks can be used to define and visualize roads with curves in the setup. Now, is not possible to define curved roads in OXYGEN Automotive directly, but only via importing KML tracks generated with 3<sup>rd</sup> party software packages.

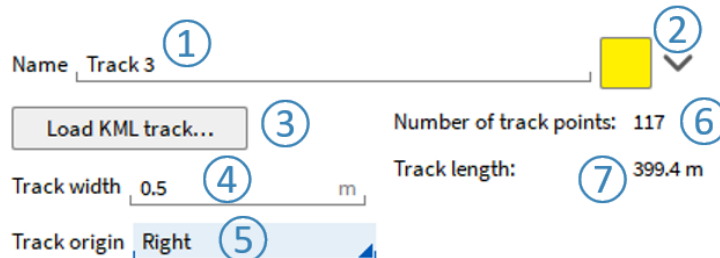

**Figure 3-22: KML track object menu – Overview**

1	<i>Object name</i>	Edit the objects' name here
2	<i>Object color</i>	Edit the objects' color here
3	<i>Load KML track</i> button	Opens a UI to select the desired KML track
4	<i>Track width</i> column	Enter the track width here
5	<i>Track origin</i> column	Use kml-data as center, left or right boundary of track
6	<i>Number of points</i> display	Information about the number of track points, the loaded KML track consists of
7	<i>Track length</i> display	Information about the track length of the laded KML track

**Table 3-7: KML track object menu – Overview**

### 3.5.6 TRACK LINES

Track line objects can be used to define and visualize straight roads in the setup, i.e. to illustrate if a vehicle is following a predefined route or if it diverges.

#### 3.5.6.1 Track line Object Menu

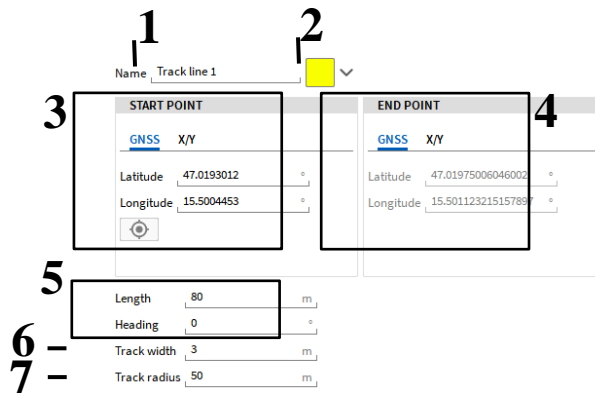

Figure 3-23: Track line object menu – Overview

1	Object name	Edit the objects' name here
2	Object color	Edit the objects' color here
3	<i>Start point</i> menu	Enter the coordinates of the Start point as GNSS coordinates or X/Y-coordinates here
4	<i>End point</i> menu	Enter the coordinates of the End point as GNSS coordinates or X/Y-coordinates here
5	<i>Length and Heading</i> menu	Enter Length and Heading of the Straight Track here
6	<i>Track width</i> column	Enter the track width here
7	<i>Track radius</i>	Enter the track line's radius to get an arc (use +/- to change direction)

Table 3-8: Track line object menu – Overview

#### 3.5.6.2 Definition of a Track line

Two different possibilities to create a track line in the setup:

- Via Start point and End point
- If the track shall be defined via the absolute GNSS coordinates of the start and end point of the track, the two GNSS coordinates can be entered in the Start point- GNSS menu (see ③ Figure 3-23) and the End point – GNSS menu (see ④ Figure 3-23). If a Locator object is defined, the positions of a Locator object can also be copied to the start and end point.
- In addition, the X/Y- coordinates of the start and end point referring to the origin of the coordinate system defined in the Location setup (see section 3.4.3) can be entered in the Start point – X/Y and End Point – X/Y menu (see Figure 3-24).

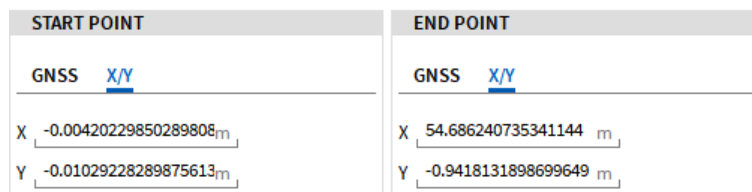

Figure 3-24: Start and End Point definition via X/Y coordinates

Length and Heading displayed in ⑤ of Figure 3-23 are updated hereby automatically and must not be edited!

- Via Start point, Length and Heading
- If the track shall be defined via the absolute GNSS coordinate of the Start point and the corresponding track length and its heading, the GNSS coordinate of the Start point can be entered in the Start point- GNSS menu (see ③ Figure 3-23). The corresponding Heading and the track length can be entered in the Length and Heading menu (see ⑤ in Figure 3-23).
- In addition, the Start point may also be defined via its X/Y coordinates referring to the origin of the coordinate system defined in the Location setup (see section 3.4.3). This assignment can be done in the Start point – X/Y menu (see Figure 3-24).
- The End Point is updated hereby automatically and must not be edited!

**Hint:** If the position is defined via X/Y coordinates, relative to the main cartesian coordinate system, moving its origin or rotating it also moves or rotates those objects.

### 3.5.6.3 Track line with radius (arc)

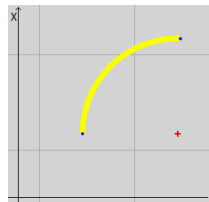

Figure 3-25: Track with radius

When entering a radius (+/- for direction), an arc element is created. Then, only the start point can be edited (GNSS or X/Y input), the end point is always calculated.

### 3.5.7 DIN 70000 VS SAE COORDINATE SYSTEM<sup>1</sup>

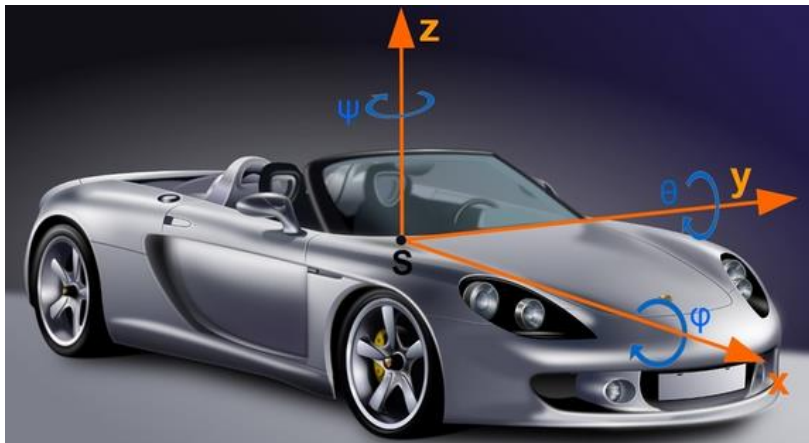

Figure 3-26: DIN 70000 coordinate system definition

<sup>1</sup> Source: <https://www.ingenieurkurse.de/fahrzeugtechnik/fahrzeugklassen/koordinatensysteme-in-der-fahrzeugtechnik.html>



Figure 3-27: SAE coordinate system definition

### 3.6 CALCULATIONS MENU

The Calculations setup is to define distance calculations between defined objects.

#### 3.6.1 OVERVIEW



Figure 3-28: Objects tab – Overview

1	<i>Calculations list</i>	The created calculations are listed here and can be selected to change their settings
2	<i>Add button</i>	Adds a calculation to the setup
3	<i>Delete button</i>	Deletes the calculation that is currently selected in the <i>Calculations list</i>
4	<i>Result preview</i>	Preview of the Current calculation result
5	<i>Calculation name selection</i>	Edit the name of the calculation here
6	<i>Distance type selection</i>	Select the distance type of the calculation, for details, please refer to section 3.6.3
7	<i>Sign selection</i>	Select the sign of the calculation; For details, please refer to section 3.6.3
8	Settings for calculation Object 1; For details, please refer to section 3.6.2	
9	Settings for calculation Object 2; For details, please refer to section 3.6.2	
10	<i>Preview window</i>	Preview of the objects and the loaded image; Can be moved while keeping the left mouse button pressed
11	<i>Rotate button</i>	The heading of the preview can be changed here
12	<i>Zoom bar</i>	The zoom factor of the preview can be adjusted manually here; Zoom can be applied with the mouse wheel as well
13	<i>Center coordinates definition</i>	The coordinates of the preview center are displayed and can be edited here
14	<i>Eye button</i>	A click on this button zooms the preview automatically to a zoom factor which displays the Objects corresponding to the selected calculation in the preview window.

Table 3-9: Objects tab – Overview

### 3.6.2 DEFINING A DISTANCE CALCULATION - CALCULATION OBJECT SETTINGS

- Click on the Add button (see ② in Figure 3-28) to add a new calculation
- Select Object 1 for the distance calculation (marked with red in Figure 3-29)
- Select the Point of interest of the object (marked with green in Figure 3-29)

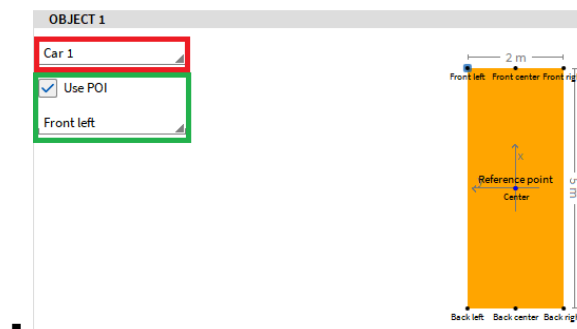

Figure 3-29: Calculation menu for Object 1

- Depending on the selected Object, different points can be selected the calculation shall be applied to:
  - Vehicles: All defined POIs and be sued for distance calculations. If the Use POI checkbox is deselected, the nearest distance to the contour of the vehicle is used for the distance calculation between objects. Linear interpolation is applied between two contour points. Therefore, the calculation is more accurate the more contour points were created. For details, please refer to section 3.7.2.2.
  - Cones: As Cones are only GNSS positions and have no geometry, the distance calculation can only be applied to the entire object
  - Locators: As Locators are only GNSS positions and have no geometry, the distance calculation can only be applied to the entire object
- After that, select Object 2 for the distance calculation (marked with red in Figure 3-30).

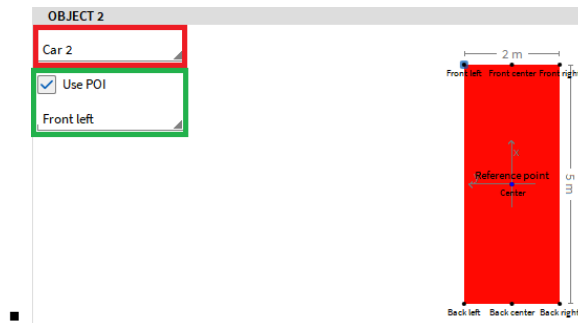

Figure 3-30: Calculation menu for Object 2

- Depending on the selected Object, different points can be selected the calculation shall be applied to:
  - Vehicles: All defined POIs and be sued for distance calculations. If the Use POI checkbox is deselected, the nearest distance to the contour of the vehicle is used for the distance calculation between objects. Linear interpolation is applied between two contour points. Therefore, the calculation is more accurate the more contour points were created. For details, please refer to section 3.7.2.2.
  - Cones: As Cones are only GNSS positions and have no geometry, the distance calculation can only be applied to the entire object
  - Locators: As Locators are only GNSS positions and have no geometry, the distance calculation can only be applied to the entire object
  - KML Tracks: Either the track center line or the nearest edge line can be selected for distance calculations
  - Track lines: Either the track center line or the nearest edge line can be selected for distance calculations
- After finishing the selection, the actual distance result will be visible in the Result Preview (see ④ in Figure 3-28)
- Each calculation that was created can be found in the Channel List to use it for further mathematical calculations or to display the result in an instrument. The calculations can be found in the Channel List under Local Node → BirdsEye→ Calculation x (see Figure 3-31).

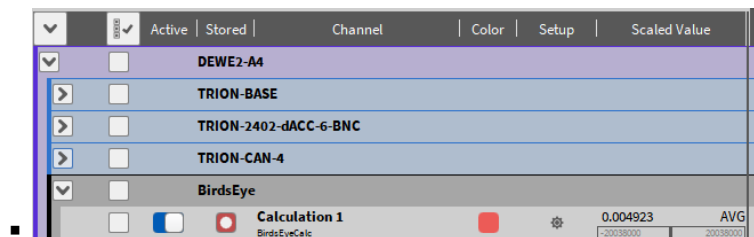

Figure 3-31: Calculations in the Channel List topology

### 3.6.3 CALCULATION - DISTANCE TYPE SELECTION

- As each calculation needs its own coordinate system, the chosen point of interest of Object 1 is regarded as the origin of the calculation. The X-Axis of the coordinate system points into the direction of the object’s heading.

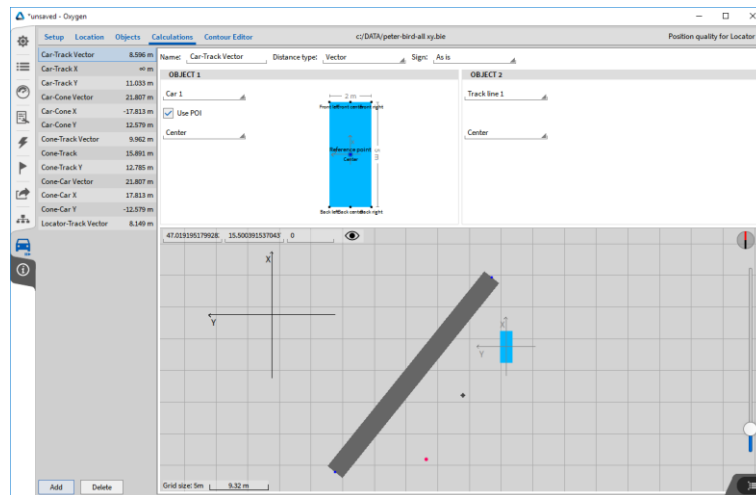

Figure 3-32: Object1 reference coordinate system for calculation

- In Figure 1-1Figure 3-32, the upper left coordinate system is the main cartesian system. For the selected calculation, Object 1’s referenced coordinate system is shown. This system is used for the calculation when X or Y distance type is chosen.
- This is also where the sign of the calculation comes from. Some examples can be found in section 3.6.3 and 3.6.4. For details about distance calculations including Tracks, please refer to Figure 3-42.
- Please note that Tracks and KML-Tracks cannot be assigned to Object 1 of a calculation, because the calculations cannot be referred to a discrete point of a Track but only to the center line or the nearest edge line.

The following distance types for a calculation can be selected:

- *Vector: Vectoral distance between both object points means the Euclidean distance, i.e. the distance to nearest point or the closest distance*
- X: Distance between both object points in X-direction. Origin of the coordinate system is the selected point of Object 1
- Y: Distance between both object points in Y-direction. Origin of the coordinate system is the selected point of Object 1
- Example 1 (see Figure 3-34):
  - Object 1: Car1 (Orange) Length: 5m; Width: 2m; The cars’ front is heading to the top
  - Object 2: Car2 (Red) Length: 5m, Width: 2m; The cars’ front is heading to the top



Figure 3-33: Calculation Example 1

- Calculation point of Car 1: Front left (marked blue in Figure 3-33)
- Calculation point of Car 2: Front left (marked green in Figure 3-33)
- Distance type: X (see white arrow in Figure 3-33)
- Sign: As is
- ➔ Result: -0.666m; As Car1 is assigned to Object 1, the origin of the coordinate system is located at the point Front Left of Car 1 (see Figure 3-33)

▪ Example 2 (see Figure 3-34):

- Object 1: Car1 (Orange) Length: 5m; Width: 2m; The cars' front is heading to the top
- Object 2: Car2 (Red) Length: 5m, Width: 2m; The cars' front is heading to the top

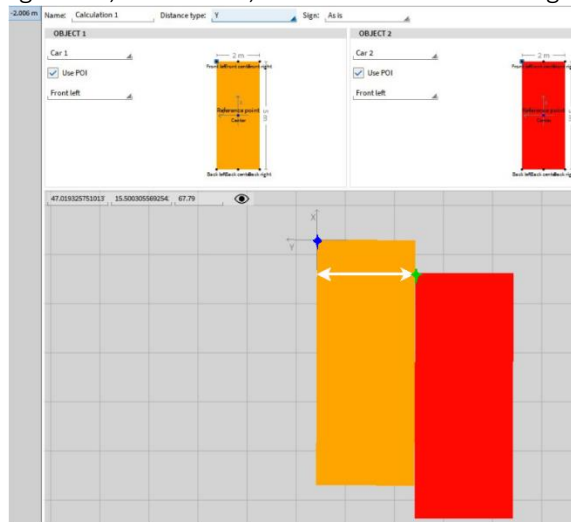

Figure 3-34: Calculation Example 2

- Calculation point of Car 1: Front left (marked blue in Figure 3-34)
- Calculation point of Car 2: Front left (marked green in Figure 3-34)
- Distance type: Y (see white arrow in Figure 3-34)
- Sign: As is
- ➔ Result: -2.006m; As Car1 is assigned to Object 1, the origin of the coordinate system is located at the point *Front Left* of Car 1 (see Figure 3-34)

▪ Example 3 (see Figure 3-35):

- Object 1: Car1 (Orange) Length: 5m; Width: 2m; The cars' front is heading to the top
- Object 2: Car2 (Red) Length: 5m, Width: 2m; The cars' front is heading to the top

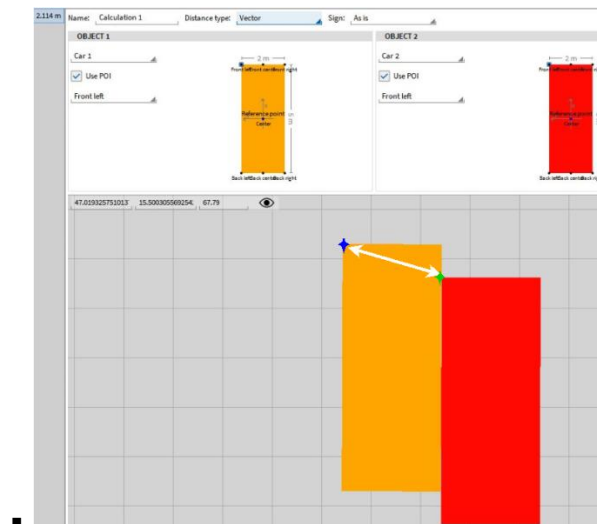

Figure 3-35: Calculation Example 3

- Calculation point of Car 1: Front left (marked blue in Figure 3-35)
  - Calculation point of Car 2: Front left (marked green in Figure 3-35)
  - Distance type: Y (see white arrow in Figure 3-35)
  - Sign: As is
  - ➔ Result: 2.114m; No coordinate system origin is displayed, because the vectoral sum of X and Y has always a positive sign
- Example 4 (see Figure 3-36):

- Object 1: Car2 (Red) Length: 5m; Width: 2m; The cars' front is heading to the top
- Object 2: Car1 (Orange) Length: 5m, Width: 2m; The cars' front is heading to the top

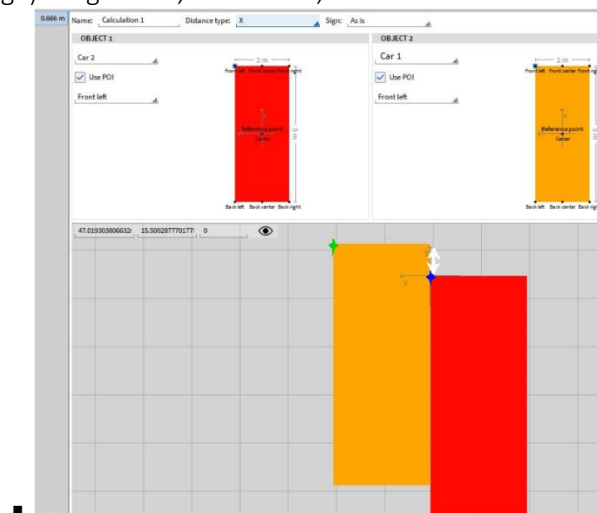

Figure 3-36: Calculation Example 4

- Calculation point of Car 1: Front left (marked green in Figure 3-36)
- Calculation point of Car 2: Front left (marked blue in Figure 3-36)
- Distance type: X (see white arrow in Figure 3-36)
- Sign: As is
- ➔ Result: 0.666m; As Car 2 is assigned to Object 1, the origin of the coordinate system is located at the point Front Left of Car 2 (see Figure 3-36)

■ Example 5 (see Figure 3-37):

- Object 1: Car2 (Red) Length: 5m; Width: 2m; The cars' front is heading to the top
- Object 2: Car1 (Orange) Length: 5m, Width: 2m; The cars' front is heading to the top

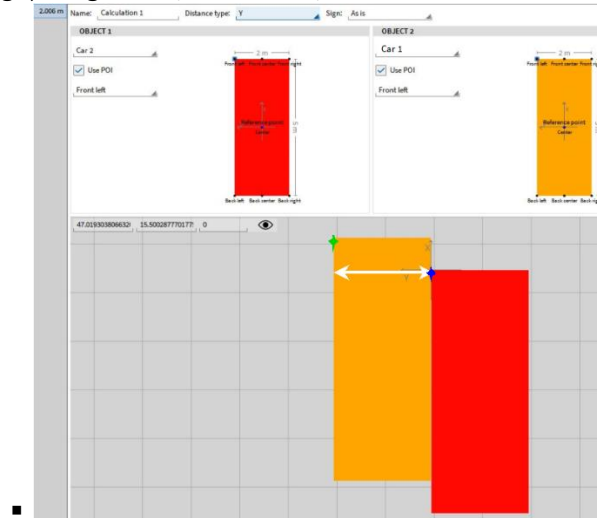

Figure 3-37: Calculation Example 5

- Calculation point of Car 1: Front left (marked green in Figure 3-37)
- Calculation point of Car 2: Front left (marked blue in Figure 3-37)
- Distance type: Y (see white arrow in Figure 3-37)
- Sign: As is
- ➔ Result: 2.006m; As Car 2 is assigned to Object 1, the origin of the coordinate system is located at the point Front Left of Car 2 (see Figure 3-37)

■ Example 6 (see Figure 3-38):

- Object 1: Car1 (Orange) Length: 5m; Width: 2m; The cars' front is heading to the top
- Object 2: Car2 (Red) Length: 5m, Width: 2m; The cars' front is heading to the top

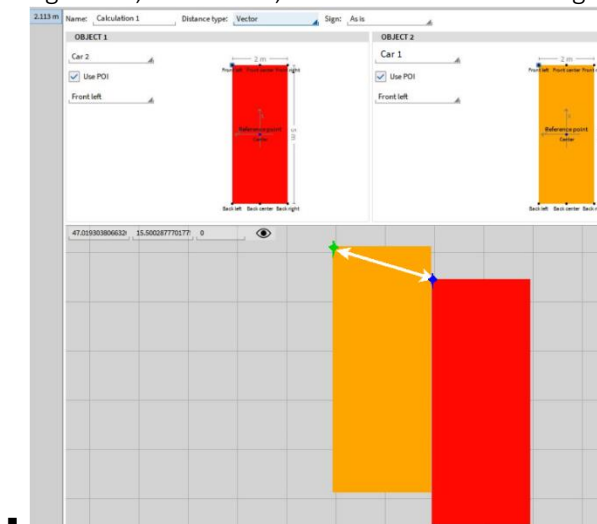

Figure 3-38: Calculation Example 6

- Calculation point of Car 1: Front left (marked blue in Figure 3-38)
- Calculation point of Car 2: Front left (marked green in Figure 3-38)
- Distance type: Vector (see white arrow in Figure 3-38)
- Sign: As is

➔ Result: 2.113m; No coordinate system origin is displayed, because the vectoral sum of X and Y has always a positive sign

▪ Example 7 (see Figure 3-39):

- Object 1: Car2 (Red) Length: 5m; Width: 2m; The cars' front is heading to the top
- Object 2: Car1 (Orange) Length: 5m, Width: 2m; The cars' front is heading to the top

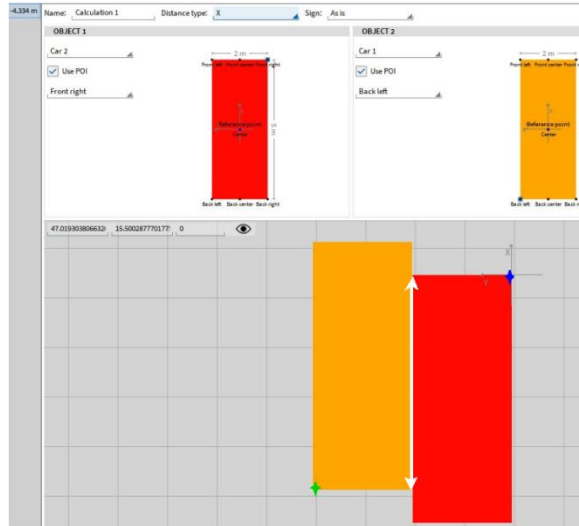

Figure 3-39: Calculation Example 7

- Calculation point of Car 2: Front right (marked blue in Figure 3-39)
- Calculation point of Car 1: Back left (marked green in Figure 3-39)
- Distance type: X (see white arrow in Figure 3-39)
- Sign: As is

➔ Result: -4.334m; As Car 2 is assigned to Object 1, the origin of the coordinate system is located at the point Front right of Car 2 (see Figure 3-39)

▪ Example 8 (see Figure 3-40):

- Object 1: Car2 (Red) Length: 5m; Width: 2m; The cars' front is heading to the top
- Object 2: Car1 (Orange) Length: 5m, Width: 2m; The cars' front is heading to the top

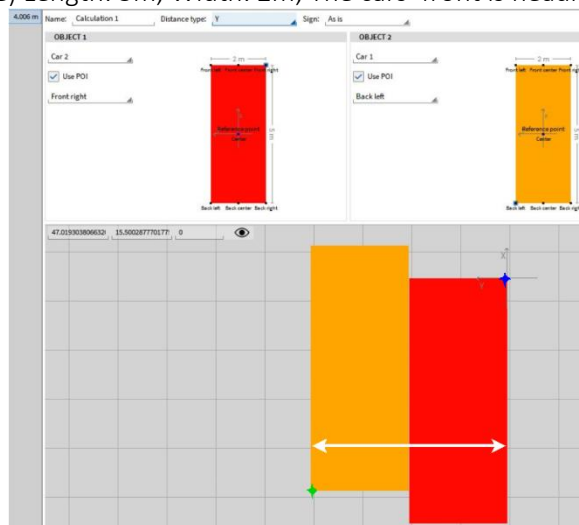

Figure 3-40: Calculation Example 8

- Calculation point of Car 2: Front right (marked blue in Figure 3-40)
- Calculation point of Car 1: Back left (marked green in Figure 3-40)
- Distance type: Y (see white arrow in Figure 3-40)

- Sign: As is
- ➔ Result: 4.006m; As Car 2 is assigned to Object 1, the origin of the coordinate system is located at the point Front right of Car 2 (see Figure 3-40)
- Example 9 (see Figure 3-41):
  - Object 1: Car2 (Red) Length: 5m; Width: 2m; The cars' front is heading to the top
  - Object 2: Car1 (Orange) Length: 5m, Width: 2m; The cars' front is heading to the top

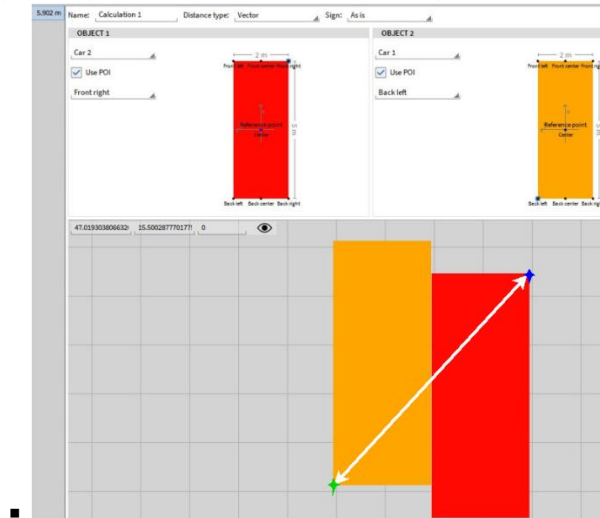

Figure 3-41: Calculation Example 9

- Calculation point of Car 2: Front right (marked blue in Figure 3-41)
- Calculation point of Car 1: Back left (marked green in Figure 3-41)
- Distance type: Vector (see white arrow in Figure 3-41)
- Sign: As is
- ➔ Result: 5.902m; No coordinate system origin is displayed, because the vectoral sum of X and Y has always a positive sign
- Distance calculations including tracks:

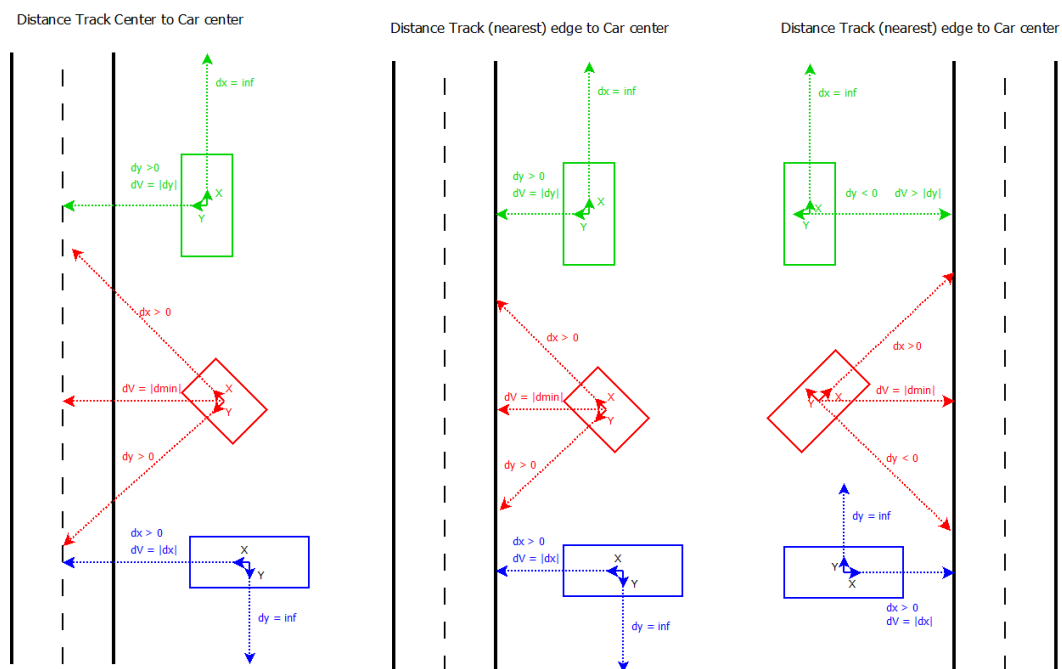

Figure 3-42: Distance calculations from Car to Track

### 3.6.4 CALCULATION—SIGN SELECTION

The following sign settings can be selected:

- As Is: Applies the mathematical correct sign to the calculation result
- Absolute: Displays the absolute value of the calculation result
- Invert: Inverts the sign of the calculation result (i.e. As workaround if Object 1 and Object 2 were mixed up)
- Example 10 (see Figure 3-43):
  - Object 1: Cone1 (Green) Coordinates: X=2, Y=2
  - Object 2: Cone2 (Purple) Coordinates: X=2, Y=-2

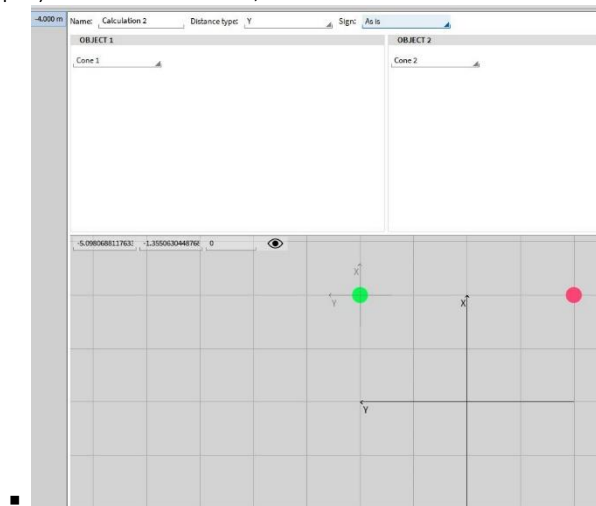

Figure 3-43: Calculation Example 10

- Distance type: Y
- Sign: As is
- ➔ Result: -4m
- Example 11 (see Figure 3-44):

- Object 1: Cone1 (Green) Coordinates: X=2, Y=2
- Object 2: Cone2 (Purple) Coordinates: X=2, Y=-2

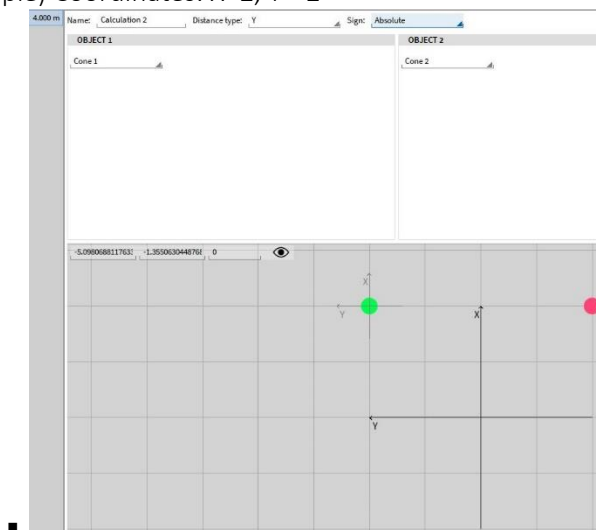

Figure 3-44: Calculation Example 11

- Distance type: Y
- Sign: Absolute
- ➔ Result: +4m

▪ Example 12 (see Figure 3-45):

- Object 1: Cone1 (Green) Coordinates: X=2, Y=2
- Object 2: Cone2 (Purple) Coordinates: X=2, Y=-2

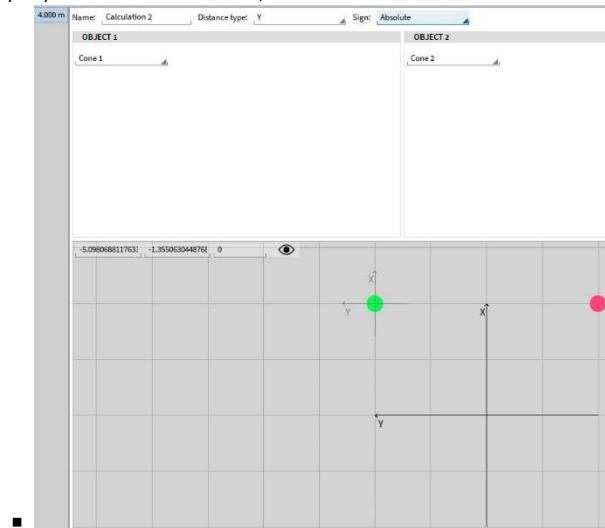

Figure 3-45: Calculation Example 12

- Distance type: Y
- Sign: Invert
- ➔ Result: +4m

## 3.7 CONTOUR EDITOR MENU

### 3.7.1 OVERVIEW

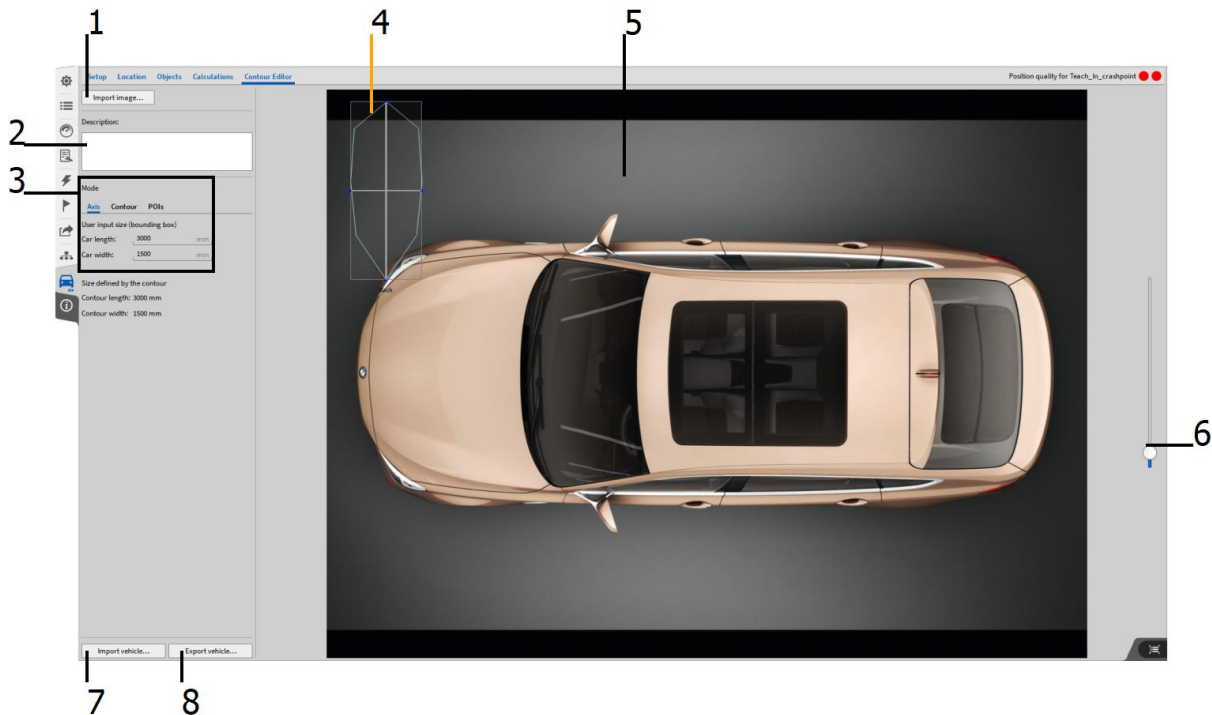

Figure 3-46: Contour Editor tab – Overview

1	<i>Import Image</i> button	Import the contour image from the desired car here
2	Space for individual and general	contour description and comments
3	<i>Mode (Axis, Contour, POIs)</i> menu	Menu for defining the car dimensions, the cars' shape and its POIs
4	Reference Rectangular	Reference rectangular for matching the entered car dimensions to the car in the loaded image
5	<i>Preview and working</i> window	The contour of the car can be designed here
6	<i>Zoom</i> bar	The zoom factor of the preview can be adjusted manually here
7	<i>Import vehicle...</i> button	Import a previously stored contour xml-file again here
8	<i>Export vehicle...</i> button	Export the created contour to a xml-file

Table 3-10: Contour Editor menu – Overview

In the past, a vehicle was often regarded just as simple rectangular box. But since the design of modern cars is more than just simple boxes, the contour editor can create complex shapes and allows more realistic and complex distance calculations. Moreover, the seven predefined NCAP POIs (points of interest) for ADAS testing distributed on the cars' front bumper can be added with one single click to the contour and don't need to be measured by the engineer manually any more.

The basis for the contour editor is a top view image or drawing of the desired car. The only parameters to be known are the length and the width of the car. The steps to create a cars' shape and add the NCAP POIs as well as additional user defined POIs are explained in the following section.

### 3.7.2 CREATING A CARS' SHAPE AND POIS WITH THE CONTOUR EDITOR

#### 3.7.2.1 Adjusting the Cars' Length and Width

- Import a top view image or drawing of the desired vehicle by clicking on the Import Image... button (see ① in Figure 3-46)
- After loading is finished, the image will be visible in the Preview and Working window (see ⑤ in Figure 3-46)
- Enter the car length and width in the respective columns in the Mode – Axis menu (see Figure 3-47)

Mode	
Axis	Contour POIs
User input size (bounding box)	
Car length:	4899 mm
Car width:	1831 mm
Size defined by the contour	
Contour length:	4899 mm
Contour width:	1831 mm

Figure 3-47: Contour Editor - *Mode- Axis* menu

- These settings will be copied to the Contour length and Contour width column (see Figure 3-47).
- Now, the Reference Rectangular (see ④ in Figure 3-46) represents the entered dimensions of the car length and width
- The Reference Rectangular must now be matched to the car's dimensions of the loaded image (see Figure 3-48). Therefore, drag and drop the Front point of the Reference Rectangular to the middle of the cars' front bumper, the Back point of the Reference Rectangular to the middle of the cars' back bumper, and adjust one of the two side points to the cars' width. As cars are normally symmetrical designed, the second side point will be adjusted in parallel to the first one.
- Be aware that the front and back assignment is done correctly. Otherwise the NCAP POIS will be attached to the cars' back bumper.

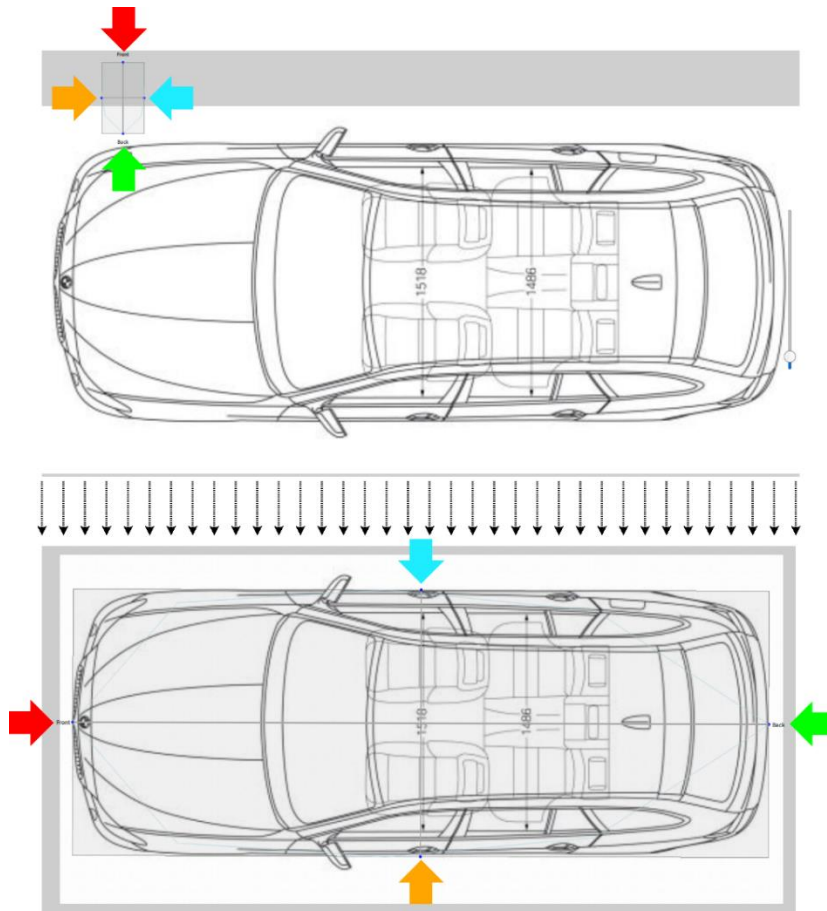

Figure 3-48: Assignment of the *Reference Rectangular* to the imported image

- The entered car length and width is now matched to the image

**Remark:** For sure, the contour editor can also be used to define the shape of other objects than cars. For AEB tests, the contour editor can be used to define the shape of VUTs (Vehicle Under Test) GVTs (Global Vehicle Target), the EBT (European Bicycle Target), the EPTa (European Pedestrian Target adult) or the EPTc (European Pedestrian Target child).

### 3.7.2.2 Defining the Cars' Contour

- Next, the contour of the car must be defined. The cars' image is the basis for that.
- Therefore, swap to the Mode - Contour menu tab (marked red in Figure 3-49). Some predefined green contour points will appear in the image along predefined light blue lines (marked with green arrows in Figure 3-49). This is the default contour which can be edited now according to the cars' shape.

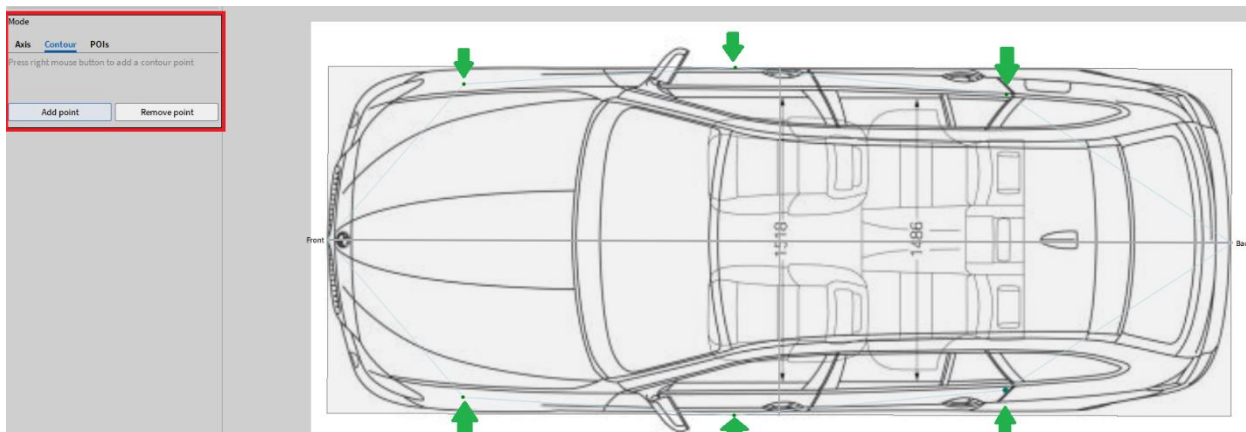
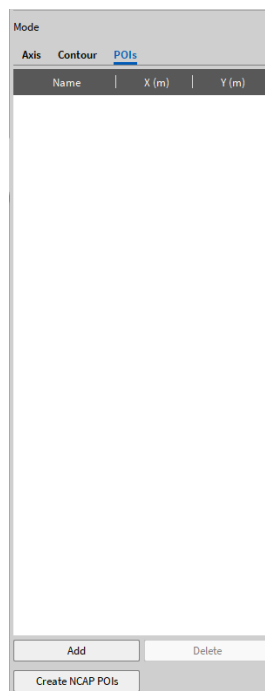

**Figure 3-49: Creating the cars' shape**

- The user can add new contour points by right clicking to the desired position on the image or by clicking on the Add point button the Contour menu (see Figure 3-49).
- Existing contour points can be dragged and dropped to another position with the left mouse button
- Needless contour points can be deleted by selecting them with the left mouse button and pressing the DEL-button on the keyboard or by pressing the Remove point button in the Contour menu see Figure 3-49)
- The more contour points, the more accurate the cars' shape and the more accurate distance the distance calculations between vehicle objects and others explained in section 3.6.
- As the shape of a car is regarded as symmetric, it is enough to define the contour for one side of the car. The contour of the other side is created automatically and in parallel to the first side.
- The contour definition is finished now.

### 3.7.2.3 Adding POIs to the Contour

- Next, the predefined EURO NCAP POIs can be added to the cars' front bumper and additional user defined POIS can be added as well
- Swap to the Mode – POIs menu (see Figure 3-50)

**Figure 3-50: Mode - POIs menu**

- A click on the Create NCAP POIs button (see Figure 3-50) will automatically create and distribute the predefined seven predefined EURO NCAP POIs along the cars' front bumper (see Figure 3-51). The coordinates will be displayed in the table of the Mode – POIs menu.

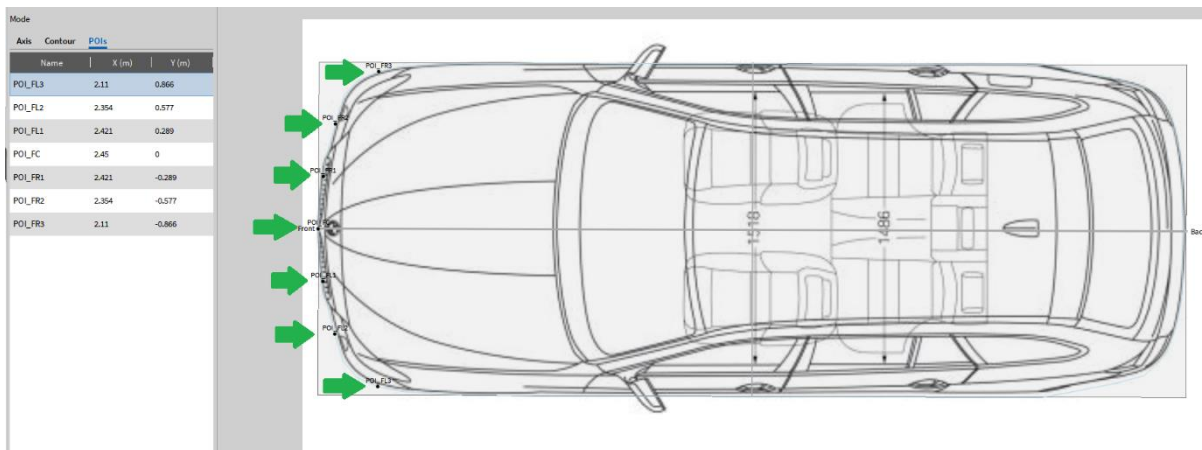

Figure 3-51: Contour with added NCAP POIs

- Additional and user defined POIs, like the cars' geometrical center or the center of gravity, can be added by clicking on the Add button (see Figure 3-50).
- The position of POIs can be changed by editing the X- and Y-coordinates in the table in the Mode – POIs menu or by dragging and dropping them with the left mouse button on the cars' image.
- Needless POIs can be deleted by selecting them with the left mouse button and pressing the Delete button in the Contour menu see Figure 3-50)

#### 3.7.2.4 Export and Import of contour files

- After all POIs are created, the cars' contour can be exported to a xml- file by pressing the Export vehicle... button (see ⑧ in Figure 3-46).
- For editing contours later again, they can also be imported later again by pressing the Import vehicle... button (see ⑦ in Figure 3-46)

## 4 BIRDSEYE INSTRUMENT

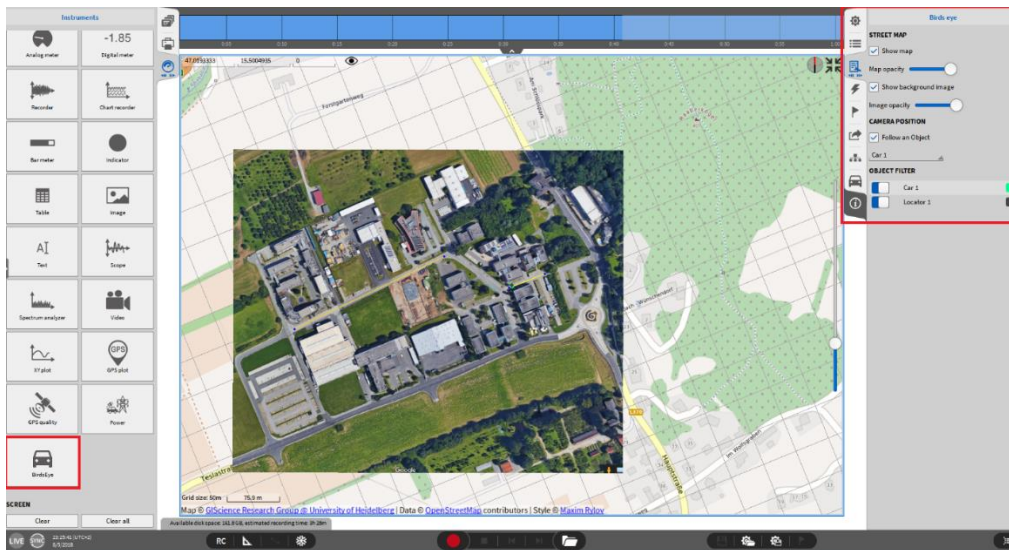

Figure 4-1: BirdsEye instrument – Overview

To visualize all created objects during the measurement in the *REC* mode and during data analysis in the *PLAY* mode, the BirdsEye instrument can be added to the measurement screen (see Figure 4-1). The instrument can be added to any measurement screen by dragging and dropping it with the left mouse button from the Instruments menu to the measurement screen. For details, please refer to the latest version of the OXYGEN Feature Manual.

The Latitude and Longitude displayed in the upper left corner of the instrument are the coordinates of the current center position. The card can be moved by dragging and dropping it with the left mouse button or by changing these coordinates.

The Rotate button in the upper right corner may be used to change the instruments' heading. It can also be edited by entering another heading in the upper left corner.

The zoom bar on the right side may be used to change the instruments' zoom factor.

The Instrument has the following properties (can be opened with a double click into the BirdsEye instrument or by selecting on the screen and clicking on the Instrument Properties menu (see the right side of Figure 4-1)):

- **Street Map:** If the PC has a valid internet connection, an OpenStreetMap© is displayed in the instrument. This map can be (de-)hidden by (de-)selecting the Show map checkbox. The opacity of the map can be edited with the Map opacity bar.
- **The background image** which was imported and adjusted in the Location setup (see section 3.4) is displayed in front of the OpenStreetMap©. The background image can be (de-)hidden by (de-)selecting the Show background image checkbox. The opacity of the image can be edited with the Image opacity bar. This is also a useful feature to check if the mapping of the background image to the OpenStreetMap© is satisfying.
- **Camera position:** If Follow an Object is selected, an object can be selected which is always displayed in the middle of the instrument. Changing the map position by dragging and dropping it or entering another Latitude/Longitude in the upper left corner is not applicable in this case.
- **Objects Filter:** Objects that are currently not of interest can be masked here. This is not applicable to track objects.

# 5 APPENDIX: LIST OF DECODED ADMA CHANNELS

## 5.1 ADMANET-DATA

ADMA-Data; Format Version 3.3.2

NO BARO, EVEL, DUAL ANT	ALL POIs	STANDARD (2 POIs)	DEBUG	CAN/ETH-Message-Format: ADMAnet-Data; Format Version: 3.3.2.0; Datei Version: 30.6.0.0		
				Data Package	Channel-Name	Description
				UDP-Header		
X	X	X	X	ADMA Static-Header V1.0.0.0 (*3)	GeneSys ID	Used to uniquely identify the beginning of a data packet "GBIN" = GeneSys Binary (public) "GRnD" = GeneSys debug data (not public)
X	X	X	X		Header Version	Used to uniquely identify the beginning of a data packet
X	X	X	X		Format ID	Contains the format ID of the following data
X	X	X	X		Format Version	Contains the version of the following data
X	X	X	X		Reserved	
X	X	X	X		Serial Number	ADMA serial number
X	X	X	X		Alias	ADMA Alias
X	X	X	X		ADMA Dynamic-Header V1.0.1.0 (*3)	Config ID
X	X	X	X	Config Format		Contains the config format, which is sent in the dynamic header
X	X	X	X	Config Version		Contains the Config version, which is sent in the dynamic header
X	X	X	X	Config Size		Contains the total file size of the configuration in bytes
X	X	X	X	Byte Offset		Contains the position of the "Slice Data" within the configuration file
X	X	X	X	Slice Size in Byte		Includes the size of "SliceData"
X	X	X	X	Slice Data		Values for the configuration file
X	X	X	X	Status (*3)		Status_GPS_Mode
X	X	X	X		Status_Standstill	1=Vehicle at stop
X			X		Status_Skidding	1=Vehicle is skidding
					Reserved	
					Status_External_Vel_Out	1=External velocity deviates from system velocity
X	X	X	X		Status_Trig_GPS	1=GPS receiver was sampling
X					Status_Signal_IN3	1=Signal was detected
X					Status_Signal_IN2	1=Signal was detected
X			X		Status_Signal_IN1	1=Signal was detected
X	X	X	X		Status_Alignment	1=prealignment (at start)
X			X		Status_AHRS_INS	0=IMU-Modus, 1=AHRS-Modus
X			X		Status_Dead_reckoning	1=dead reckoning operation
X	X	X	X		Status_SyncLock	1=ADMA-Time is adjusted
					Status_EVK_activ	External-Velocity-Kalman filter active, control criteria fulfilled
					Status_EVK_Estimat es	External-Velocity-Kalman filter has found valid estimates

X	X	X	X		Status_Heading_executed	Initialisation of heading executed	
X					Status_Configuration_changed		
X					Status_Tilt	tilt quality 0=red, 1=yellow, 2=green	
X					Status_Pos	position quality 0=red, 1=yellow, 2=green	
X	X	X	X		Status_Count	Alignment Time countdown at measurement start, Data record count 0-255 continuously at measurement	
X	X	X	X		Status_Kalmanfilter_settled	1 = Kalman filter settled in all axes	
X			X		Status_KF_Lat_stimulated	1 = Kalman filter settled in lateral axis	
X			X		Status_KF_Long_stimulated	1 = Kalman filter settled in longitudinal axis	
X			X		Status_KF_steady-state	1 = Kalman filter bias estimates settled	
X			X		Status_Speed	Speed quality 0=red, 1=yellow, 2=green	
					Reserved		
					Reserved		
X	X	X	X		Error and Warning (*3)	Error_Hardware	HW Error of Gyro, Accelerometer, External velocity, GPS Receiver - insufficient supply voltage.
X			X			Error_Misc1	Miscellaneous HW Errors. Definition see TechDoc
X			X	Error_Misc2		Miscellaneous HW Errors. Definition see TechDoc	
X			X	Error_Misc3		Miscellaneous HW Errors. Definition see TechDoc	
X			X	Warn_GPS		Warnings GPS	
X			X	Warn_Misc1		Miscellaneous warnings, definition see TechDoc	
X			X	Error_HW_Sticky		Hardware Error counter	
				Reserved			
				Reserved			
X			X	Sensors body X	Acc_Body_HR_X	Accel high resolution in X, Body	
X			X		Rate_Body_HR_X	Rate high resolution in X, Body	
X			X	Sensors body Y	Acc_Body_HR_Y	Accel high resolution in Y, Body	
X			X		Rate_Body_HR_Y	Rate high resolution in Y, Body	
X			X	Sensors body Z	Acc_Body_HR_Z	Accel high resolution in Z, Body	
X			X		Rate_Body_HR_Z	Rate high resolution in Z, Body	
X	X	X	X	Rates body	Rate_Body_X	Rate in X, Body	
X	X	X	X		Rate_Body_Y	Rate in Y, Body	
X	X	X	X		Rate_Body_Z	Rate in Z, Body	
					Reserved		
X	X	X	X	Rates horizontal	Rate_Hor_X	Rate in X, Horizontal, longitudinal	
X	X	X	X		Rate_Hor_Y	Rate in Y, Horizontal, lateral	
X	X	X	X		Rate_Hor_Z	Rate in Z, Horizontal, vertical	
					Reserved		
X	X	X	X	Accelerations body (*2)	Acc_Body_X	Accel in X, Body, Measuring reference point	
X	X	X	X		Acc_Body_Y	Accel in Y, Body, Measuring reference point	
X	X	X	X		Acc_Body_Z	Accel in Z, Body, Measuring reference point	
					Reserved		
X	X	X	X	Accelerations horizontal (*2)	Acc_Hor_X	Accel in X, Horizontal, longitudinal, Measuring reference point	
X	X	X	X		Acc_Hor_Y	Accel in Y, Horizontal, lateral, Measuring reference point	
X	X	X	X		Acc_Hor_Z	Accel in Z, Horizontal, vertical, Measuring reference point	
					Reserved		
X	X	X			Acc_Body_X_POI1	Accel in X, Body, at POI1	
X	X	X			Acc_Body_Y_POI1	Accel in Y, Body, at POI1	

x	x	x		Accelerations POI1 body (*2)	Acc_Body_Z_POI1	Accel in Z, Body, at POI1
					Reserved	
x	x	x		Accelerations POI2 body	Acc_Body_X_POI2	Accel in X, Body, at POI2
x	x	x			Acc_Body_Y_POI2	Accel in Y, Body, at POI2
x	x	x			Acc_Body_Z_POI2	Accel in Z, Body, at POI2
					Reserved	
x	x			Accelerations POI3 body	Acc_Body_X_POI3	Accel in X, Body, at POI3
x	x				Acc_Body_Y_POI3	Accel in Y, Body, at POI3
x	x				Acc_Body_Z_POI3	Accel in Z, Body, at POI3
					Reserved	
x	x			Accelerations POI4 body	Acc_Body_X_POI4	Accel in X, Body, at POI4
x	x				Acc_Body_Y_POI4	Accel in Y, Body, at POI4
x	x				Acc_Body_Z_POI4	Accel in Z, Body, at POI4
					Reserved	
x	x			Accelerations POI5 body	Acc_Body_X_POI5	Accel in X, Body, at POI5
x	x				Acc_Body_Y_POI5	Accel in Y, Body, at POI5
x	x				Acc_Body_Z_POI5	Accel in Z, Body, at POI5
					Reserved	
x	x			Accelerations POI6 body	Acc_Body_X_POI6	Accel in X, Body, at POI6
x	x				Acc_Body_Y_POI6	Accel in Y, Body, at POI6
x	x				Acc_Body_Z_POI6	Accel in Z, Body, at POI6
					Reserved	
x	x			Accelerations POI7 body	Acc_Body_X_POI7	Accel in X, Body, at POI7
x	x				Acc_Body_Y_POI7	Accel in Y, Body, at POI7
x	x				Acc_Body_Z_POI7	Accel in Z, Body, at POI7
					Reserved	
x	x			Accelerations POI8 body	Acc_Body_X_POI8	Accel in X, Body, at POI8
x	x				Acc_Body_Y_POI8	Accel in Y, Body, at POI8
x	x				Acc_Body_Z_POI8	Accel in Z, Body, at POI8
					Reserved	
x	x	x		Accelerations POI1 horizontal (*2)	Acc_Hor_X_POI1	Accel in X, Horizontal, longitudinal, at POI1
x	x	x			Acc_Hor_Y_POI1	Accel in Y, Horizontal, lateral, at POI1
x	x	x			Acc_Hor_Z_POI1	Accel in Z, Horizontal, vertical, at POI1
					Reserved	
x	x	x		Accelerations POI2 horizontal	Acc_Hor_X_POI2	Accel in X, Horizontal, longitudinal, at POI2
x	x	x			Acc_Hor_Y_POI2	Accel in Y, Horizontal, lateral, at POI2
x	x	x			Acc_Hor_Z_POI2	Accel in Z, Horizontal, vertical, at POI2
					Reserved	
x	x			Accelerations POI3 horizontal	Acc_Hor_X_POI3	Accel in X, Horizontal, longitudinal, at POI3
x	x				Acc_Hor_Y_POI3	Accel in Y, Horizontal, lateral, at POI3
x	x				Acc_Hor_Z_POI3	Accel in Z, Horizontal, vertical, at POI3
					Reserved	
x	x			Accelerations POI4 horizontal	Acc_Hor_X_POI4	Accel in X, Horizontal, longitudinal, at POI4
x	x				Acc_Hor_Y_POI4	Accel in Y, Horizontal, lateral, at POI4
x	x				Acc_Hor_Z_POI4	Accel in Z, Horizontal, vertical, at POI4
					Reserved	
x	x			Accelerations POI5 horizontal	Acc_Hor_X_POI5	Accel in X, Horizontal, longitudinal, at POI5
x	x				Acc_Hor_Y_POI5	Accel in Y, Horizontal, lateral, at POI5
x	x				Acc_Hor_Z_POI5	Accel in Z, Horizontal, vertical, at POI5
					Reserved	
x	x			Accelerations POI6 horizontal	Acc_Hor_X_POI6	Accel in X, Horizontal, longitudinal, at POI6
x	x				Acc_Hor_Y_POI6	Accel in Y, Horizontal, lateral, at POI6

X	X				Acc_Hor_Z_POI6	Accel in Z, Horizontal, vertical, at POI6
					Reserved	
X	X			Accelerations POI7 horizontal	Acc_Hor_X_POI7	Accel in X, Horizontal, longitudinal, at POI7
X	X				Acc_Hor_Y_POI7	Accel in Y, Horizontal, lateral, at POI7
X	X				Acc_Hor_Z_POI7	Accel in Z, Horizontal, vertical, at POI7
					Reserved	
X	X			Accelerations POI8 horizontal	Acc_Hor_X_POI8	Accel in X, Horizontal, longitudinal, at POI8
X	X				Acc_Hor_Y_POI8	Accel in Y, Horizontal, lateral, at POI8
X	X				Acc_Hor_Z_POI8	Accel in Z, Horizontal, vertical, at POI8
					Reserved	
				External Velocity Analog	Ext_Vel_An_X	external Velocity (analog raw), longitudinal
					Ext_Vel_An_Y	external Velocity (analog raw), lateral
					Reserved	
					Reserved	
				External Velocity Digital Pulses	Ext_Vel_Dig_X	external Velocity (digital raw), longitudinal
					Ext_Vel_Dig_Y	external Velocity (digital raw), lateral
					Ext_Vel_Dig_Pulses_X	external Velocity counted Pulses, longitudinal
					Ext_Vel_Dig_Pulses_Y	external Velocity counted Pulses, biased, lateral
				External Velocity corrected	Ext_Vel_X_corrected	Corrected external Velocity, longitudinal
					Ext_Vel_Y_corrected	Corrected external Velocity, lateral
					Reserved	
					Reserved	
				Barometer Pressure	Ext_Baro_Pressure	Measured barometric pressure
					Reserved	
				Barometer Height	Ext_Baro_Height	Barometric height (calculated from pressure)
					Ext_Baro_Height_corrected	Corrected barometric height (not calculated as yet)
				Reserved	Reserved	
					Reserved	
X	X	X	X	Miscellaneous	Inv_Path_Radius	inverse path radius, at Measuring reference point
X	X	X	X		Side_Slip_Angle	side slip angle, inertial, at Measuring reference point
X	X	X	X		Dist_Trav	distance travelled, at Measuring reference point
X	X	X		Miscellaneous POI1	Inv_Path_Radius_POI1	inverse path radius, at POI1
X	X	X			Side_Slip_Angle_POI1	side slip angle, inertial, at POI1
X	X	X			Dist_Trav_POI1	distance travelled, at POI1
X	X	X		Miscellaneous POI2	Inv_Path_Radius_POI2	inverse path radius, at POI2
X	X	X			Side_Slip_Angle_POI2	side slip angle, inertial, at POI2
X	X	X			Dist_Trav_POI2	distance travelled, at POI2
X	X			Miscellaneous POI3	Inv_Path_Radius_POI3	inverse path radius, at POI3
X	X				Side_Slip_Angle_POI3	side slip angle, inertial, at POI3
X	X				Dist_Trav_POI3	distance travelled, at POI3
X	X			Miscellaneous POI4	Inv_Path_Radius_POI4	inverse path radius, at POI4
X	X				Side_Slip_Angle_POI4	side slip angle, inertial, at POI4
X	X				Dist_Trav_POI4	distance travelled, at POI4
X	X			Miscellaneous POI5	Inv_Path_Radius_POI5	inverse path radius, at POI5

X	X				Side_Slip_Angle_POI5	side slip angle, inertial, at POI5	
X	X				Dist_Trav_POI5	distance travelled, at POI5	
X	X				Miscellaneous POI6	Inv_Path_Radius_POI6	inverse path radius, at POI6
X	X					Side_Slip_Angle_POI6	side slip angle, inertial, at POI6
X	X					Dist_Trav_POI6	distance travelled, at POI6
X	X				Miscellaneous POI7	Inv_Path_Radius_POI7	inverse path radius, at POI7
X	X					Side_Slip_Angle_POI7	side slip angle, inertial, at POI7
X	X					Dist_Trav_POI7	distance travelled, at POI7
X	X				Miscellaneous POI8	Inv_Path_Radius_POI8	inverse path radius, at POI8
X	X					Side_Slip_Angle_POI8	side slip angle, inertial, at POI8
X	X					Dist_Trav_POI8	distance travelled, at POI8
X				X	Triggers 1 and 2 (*2)	Trig_Rising_1	external trigger e.g. Brake Pedal Trigger, etc.
X				X		Trig_Falling_1	external trigger e.g. Brake Pedal Trigger, etc.
X						Trig_Rising_2	external trigger e.g. Brake Pedal Trigger, etc.
X						Trig_Falling_2	external trigger e.g. Brake Pedal Trigger etc.
X					Triggers 3 and 4 (*2)	Trig_Rising_3	external trigger e.g. Brake Pedal Trigger etc.
X						Trig_Falling_3	external trigger e.g. Brake Pedal Trigger etc.
X						Trig_Rising_4	external trigger e.g. Brake Pedal Trigger etc.
X						Trig_Falling_4	external trigger e.g. Brake Pedal Trigger etc.
X				X	System Data (*)	System-Ta	Sampling time
X				X		System_Temp	System temperature. The source can be selected via Web interface menu Sytem.
X				X		System_TimeSinceInit	Time since last system init
X				X		System_DSP_Load	System processor load
X	X	X		X	GPS Position absolute	GPS_Lat_Abs	Latitude absolute
X	X	X		X		GPS_Long_Abs	Longitude absolute
X					GPS Position relative	GPS_Lat_Rel	relative meters in direction of latitude (X)
X						GPS_Long_Rel	relative meters in direction of longitude (Y)
X	X	X		X	GPS EPE (EPE= Expected Position Error)	GPS_Stddev_Lat	GPS-Receiver expected error of latitude (X)
X	X	X		X		GPS_Stddev_Long	GPS-Receiver expected error of longitude (Y)
X	X	X		X		GPS_Stddev_Height	GPS-Receiver expected error of hight (Z)
						Reserved	
X					GPS Velocity frame (*2)	GPS_Vel_Frame_X	GPS velocity in X, north-south
X						GPS_Vel_Frame_Y	GPS velocity in Y, east-west
X						GPS_Vel_Frame_Z	GPS velocity in Z, up-down
X						GPS_Vel_Latency	GPS velocity has a calculation based latency
X				X	GPS EVE (EVE= Expected Velocity Error) (*2)	GPS_Stddev_Vel_X	GPS-Receiver expected velocity error X
X				X		GPS_Stddev_Vel_Y	GPS-Receiver expected velocity error Y
X				X		GPS_Stddev_Vel_Z	GPS-Receiver expected velocity error Z
						Reserved	
X				X	GPS Time UTC (*2)	GPS_Time_msec	Time in Milliseconds, UTC
X				X		GPS_Time_Week	Start 0h 6-Jan-1980
X				X		Trigger_GPS	GPS sampling indicated
X	X	X		X	GPS AuxData 1 (*2)	GPS_DiffAge	Data age of the DGPS correction data received.
X	X	X		X		GPS_Sats_Used	Used satellites to compute a valid position solution.
X	X	X		X		GPS_Sats_Visible	Number of satellites the GPS receiver is actually observing.
						Reserved	

X			X	GPS AuxData 2 (*2)	GPS_Log_Delay	Number of ADMA sampling interval having passed until GPS data (the GPS data log) is available.
X			X		GPS_Receiver_Load	GPS receiver processor load.
X			X		GPS_BaseNr	Base station identifier
					Reserved	
X	X	X	X	INS Angle and GPS COG (COG = Course over Ground) (*2)	INS_Roll	Roll
X	X	X	X		INS_Pitch	Pitch
X	X	X	X		INS_Yaw	Yaw, alt. True Heading
X	X	X	X		GPS_COG	Course over Ground, only with (D)GPS in motion
X			X	GPS Height (MSL)	GPS_Height	Referenced to MSL
X			X		Undulation	Undulation of the geoid
					Reserved	
				GPS DualAnt Time UTC	GPS_DualAnt_Time_msec	Time in Milliseconds, UTC
					GPS_DualAnt_Time_Week	Weeks, Start 0h 6-Jan-1980
					Reserved	
				GPS DualAnt Angle	GPS_DualAnt_Heading	Heading DualAnt
					GPS_DualAnt_Pitch	Pitch DualAnt
					Reserved	
				GPS DualAnt Angle ETE (ETE = Expected Tilt Error)	GPS_DualAnt_Stddev_Heading	GPS-Receiver expected error Heading
					GPS_DualAnt_Stddev_Pitch	GPS-Receiver expected error Pitch
					Reserved	
X		X	X	INS Position Height (MSL)	INS_Height	Inertial height, at Measuring reference point
					Reserved	
X	X	X		INS Position Height POI1 and 2 (MSL)	INS_Height_POI1	Inertial height, at POI1
					INS_Height_POI2	Inertial height, at POI2
X	X	X		INS Position Height POI3 and 4 (MSL)	INS_Height_POI3	Inertial height, at POI3
					INS_Height_POI4	Inertial height, at POI4
X	X			INS Position Height POI5 and 6	INS_Height_POI5	Inertial height, at POI5
X	X				INS_Height_POI6	Inertial height, at POI6
X	X			INS Position Height POI7 and 8 (MSL)	INS_Height_POI7	Inertial height, at POI7
					INS_Height_POI8	Inertial height, at POI8
X	X	X	X	INS Time UTC (*2)	INS_Time_msec	Time in Milliseconds, UTC
X	X	X	X		INS_Time_Week	Weeks, Start 0h 6-Jan-1980
X	X	X	X		Leap_Seconds	Leap seconds
X	X	X	X	INS Position absolute (*2)	INS_Lat_Abs	Latitude, at Measuring reference point
X	X	X	X		INS_Long_Abs	Longitude, at Measuring reference point
X				INS Position relative	INS_Lat_Rel	Relative meters in direction of latitude, at Measuring reference point
X					INS_Long_Rel	Relative meters in direction of longitude, at Measuring reference point
X	X	X		INS Position POI1 absolute	INS_Lat_Abs_POI1	Latitude, at POI1
X	X	X			INS_Long_Abs_POI1	Longitude, at POI1
X				INS Position POI1 relative	INS_Lat_Rel_POI1	Relative meters in direction of latitude, at POI1
X					INS_Long_Rel_POI1	Relative meters in direction of longitude, at POI1
X	X	X		INS Position POI2 absolute	INS_Lat_Abs_POI2	Latitude, at POI2
X	X	X			INS_Long_Abs_POI2	Longitude, at POI2

X				INS Position POI2 relative	INS_Lat_Rel_POI2	Relative meters in direction of latitude, at POI2
X					INS_Long_Rel_POI2	Relative meters in direction of longitude, at POI2
X	X			INS Position POI3 absolute	INS_Lat_Abs_POI3	Latitude, at POI3
X	X				INS_Long_Abs_POI3	Longitude, at POI3
X				INS Position POI3 relative	INS_Lat_Rel_POI3	Relative meters in direction of latitude, at POI2
X					INS_Long_Rel_POI3	Relative meters in direction of longitude, at POI3
X	X			INS Position POI4 absolute	INS_Lat_Abs_POI4	Latitude, at POI4
X	X				INS_Long_Abs_POI4	Longitude, at POI4
X				INS Position POI4 relative	INS_Lat_Rel_POI4	Relative meters in direction of latitude, at POI4
X					INS_Long_Rel_POI4	Relative meters in direction of longitude, at POI4
X	X			INS Position POI5 absolute	INS_Lat_Abs_POI5	Latitude, at POI5
X	X				INS_Long_Abs_POI5	Longitude, at POI5
X				INS Position POI5 relative	INS_Lat_Rel_POI5	Relative meters in direction of latitude, at POI5
X					INS_Long_Rel_POI5	Relative meters in direction of longitude, at POI5
X	X			INS Position POI6 absolute	INS_Lat_Abs_POI6	Latitude, at POI6
X	X				INS_Long_Abs_POI6	Longitude, at POI6
X				INS Position POI6 relative	INS_Lat_Rel_POI6	Relative meters in direction of latitude, at POI6
X					INS_Long_Rel_POI6	Relative meters in direction of longitude, at POI6
X	X			INS Position POI7 absolute	INS_Lat_Abs_POI7	Latitude, at POI7
X	X				INS_Long_Abs_POI7	Longitude, at POI7
X				INS Position POI7 relative	INS_Lat_Rel_POI7	Relative meters in direction of latitude, at POI7
X					INS_Long_Rel_POI7	Relative meters in direction of longitude, at POI7
X	X			INS Position POI8 absolute	INS_Lat_Abs_POI8	Latitude, at POI8
X	X				INS_Long_Abs_POI8	Longitude, at POI8
X				INS Position POI8 relative	INS_Lat_Rel_POI8	Relative meters in direction of latitude, at POI8
X					INS_Long_Rel_POI8	Relative meters in direction of longitude, at POI8
X	X	X	X	INS Velocity horizontal (*2)	INS_Vel_Hor_X	Inertial velocity in X, longitudinal
X	X	X	X		INS_Vel_Hor_Y	Inertial velocity in Y, lateral
X	X	X	X		INS_Vel_Hor_Z	Inertial velocity in Z, vertical
					Reserved	
X				INS Velocity frame (*2)	INS_Vel_Frame_X	Inertial velocity in X, north-south
X					INS_Vel_Frame_Y	Inertial velocity in Y, east-west
X					INS_Vel_Frame_Z	Inertial velocity in Z, up-down
					Reserved	
X	X	X		INS Velocity POI1 horizontal (*2)	INS_Vel_Hor_X_POI1	Inertial velocity in X, longitudinal, at POI1
X	X	X			INS_Vel_Hor_Y_POI1	Inertial velocity in Y, lateral, at POI1
X	X	X			INS_Vel_Hor_Z_POI1	Inertial velocity in Z, vertical, at POI1
					Reserved	
X	X	X		INS Velocity POI2 horizontal	INS_Vel_Hor_X_POI2	Inertial velocity in X, longitudinal, at POI2
X	X	X			INS_Vel_Hor_Y_POI2	Inertial velocity in Y, lateral, at POI2
X	X	X			INS_Vel_Hor_Z_POI2	Inertial velocity in Z, vertical, at POI2
					Reserved	
X	X			INS Velocity POI3 horizontal	INS_Vel_Hor_X_POI3	Inertial velocity in X, longitudinal, at POI3
X	X				INS_Vel_Hor_Y_POI3	Inertial velocity in Y, lateral, at POI3

X	X				INS_Vel_Hor_Z_POI3	Inertial velocity in Z, vertical, at POI3
					Reserved	
X	X			INS Velocity POI4 horizontal	INS_Vel_Hor_X_POI4	Inertial velocity in X, longitudinal, at POI4
X	X				INS_Vel_Hor_Y_POI4	Inertial velocity in Y, lateral, at POI4
X	X				INS_Vel_Hor_Z_POI4	Inertial velocity in Z, vertical, at POI4
					Reserved	
X	X			INS Velocity POI5 horizontal	INS_Vel_Hor_X_POI5	Inertial velocity in X, longitudinal, at POI5
X	X				INS_Vel_Hor_Y_POI5	Inertial velocity in Y, lateral, at POI5
X	X				INS_Vel_Hor_Z_POI5	Inertial velocity in Z, vertical, at POI5
					Reserved	
X	X			INS Velocity POI6 horizontal	INS_Vel_Hor_X_POI6	Inertial velocity in X, longitudinal, at POI6
X	X				INS_Vel_Hor_Y_POI6	Inertial velocity in Y, lateral, at POI6
X	X				INS_Vel_Hor_Z_POI6	Inertial velocity in Z, vertical, at POI6
					Reserved	
X	X			INS Velocity POI7 horizontal	INS_Vel_Hor_X_POI7	Inertial velocity in X, longitudinal, at POI7
X	X				INS_Vel_Hor_Y_POI7	Inertial velocity in Y, lateral, at POI7
X	X				INS_Vel_Hor_Z_POI7	Inertial velocity in Z, vertical, at POI7
					Reserved	
X	X			INS Velocity POI8 horizontal	INS_Vel_Hor_X_POI8	Inertial velocity in X, longitudinal, at POI8
X	X				INS_Vel_Hor_Y_POI8	Inertial velocity in Y, lateral, at POI8
X	X				INS_Vel_Hor_Z_POI8	Inertial velocity in Z, vertical, at POI8
					Reserved	
X	X	X	X	INS EPE (EPE = Expected Position Error)	INS_Stddev_Lat	Inertial expected error of latitude (X)
X	X	X	X		INS_Stddev_Long	Inertial expected error of longitude (Y)
X	X	X	X		INS_Stddev_Height	Inertial expected error of height (Z)
					Reserved	
X	X	X	X	INS EVE and INS ETE (EVE = Expected Velocity Error) (ETE = Expected Tilt Error)	INS_Stddev_Vel_X	Inertial expected error velocity X
X	X	X	X		INS_Stddev_Vel_Y	Inertial expected error of velocity Y
X	X	X	X		INS_Stddev_Vel_Z	Inertial expected error of velocity Z
X	X	X	X		INS_Stddev_Roll	Inertial expected error of Roll
X	X	X	X		INS_Stddev_Pitch	Inertial expected error of Pitch
X	X	X	X		INS_Stddev_Yaw	Inertial expected error of Yaw
					Reserved	
			X	Analog In1	AN1	Analog IN1
					AN2	Analog IN2
					AN3	Analog IN3
					AN4	Analog IN4
X	X		X	Kalmanfilter Status (*2)	KF_Lat_stimulated	Kalman filter settled in lateral axis, in percent
X	X		X		KF_Long_stimulated	Kalman filter settled in longitudinal axis, in percent
X	X		X		KF_steady-state	Kalman filter bias estimates settled, in percent
					Reserved	
				GNSS Receiver Status (*2)	Receiver_Error	Various status parameters of the GNSS receiver system.
					Receiver_Status	Various error parameters of the GNSS receiver system.

(\*1) The actual terminal value depends on the ADMA type. Subject to change.

(\*2) ADMA-Speed BASIC version data package

(\*3) ADMA default data package

B = BASE ID CAN

## 5.2 ADDON DELTA DATA

STANDARD	RELATIVE ONLY	CAN/ETH-Message-Format: AddOn-DELTA; Format Version: 7.0; Datei Version: 30.5.x.x		
		Data Package	Channel-Name	Description
		UDP-Header		
		ABD-Header	Unavailable	
X		Delta_Target_Longitude	Target_Longitude_Integer	Target longitude integer value
X			Target_Longitude_Decimal_places	Target longitude decimal places
X		Delta_Target_Latitude	Target_Latitude_Integer	Target latitude integer value
X			Target_Latitude_Decimal_places	Target latitude decimal places
		Delta_Version	Reserved	
X			Code_version	Code version
			Reserved	
X	X	Delta_Longitudinal	Long_Delta_Distance	Longitudinal distance
X	X		Long_Delta_Velocity	Longitudinal difference velocity
X	X	Delta_Lateral	Lat_Delta_Distance	Lateral distance, Positive left
X	X		Lat_Delta_Velocity	Lateral difference velocity, Positive left
X	X	Delta_Resultant	Resultant_Distance	Resultant distance
X	X		Resultant_Velocity	Resultant velocity
X	X	Delta_Angle	Angle_of_Orientation	Angle of target in view of the hunter. Positive anti clockwise. Hunter Yaw (NED) – Target Yaw (NED) +/- 180 deg
			Reserved	
			Reserved	
X	X	Delta_Time_ForwardVel	Delta_Time	Time stamp of Synchronised DELTA data. GPS Time (milliseconds from midnight) (GPS time, milliseconds from midnight)
X			Target_Forward_Velocity	Target forward velocity
X			Hunter_Forward_Velocity	Hunter forward velocity
X		Delta_ForwardAccel_LatVel	Target_Forward_Acceleration	Target forward acceleration
X			Hunter_Forward_Acceleration	Hunter forward acceleration
X			Target_Lateral_Velocity	Target lateral velocity
X			Hunter_Lateral_Velocity	Hunter lateral velocity
X		Delta_LatAccel_PitchAngle	Target_Lateral_Acceleration	Target lateral acceleration
X			Hunter_Lateral_Acceleration	Hunter lateral acceleration
X			Target_Pitch_Angle	Target pitch angle (ISO positive in braking)
X			Hunter_Pitch_Angle	Hunter pitch angle (ISO positive in braking)
X	X	Delta_GPS_Mode	Target_GPS_Mode	Coded status information of the Hunter ADMA.
X	X		Hunter_GPS_Mode	Coded status information of the Hunter ADMA.
			Reserved	

(1) The actual terminal value depends on the ADMA type

B = BASE ID CAN

## 5.3 ADMA BRAKING DATA

ADMA Braking				
VERSION "ETH-Message-Format: Braking-Data; XML-Type: GeneSys; Format Version: 1.0.0.0; File Version: 30.4.1.0"				
	Data Package	Channel-Name	Description	
X	UDP-Header			
X	Format Header	GeneSys ID	Used to uniquely identify the beginning of a data packet "GBIN" = GeneSys Binary (public) "GRnD" = GeneSys debug data (not public)	
X		Dynamic Header Version	Used to uniquely identify the beginning of a data packet	
X		Format ID	Contains the format ID of the following data	
X		Format Version	Contains the version of the following data	
X		Format Name	Contains name of Data	
X		Header Size	Contains bit size of header	
X		Data Size	Cotains Bit size of Data	
X		INST_TIME.UTC	INS_Time_msec	Time in milliseconds from 0 to 604800000 ms (UTC)
X	INS_Time_Week		Time in weeks from 0 to 65536 weeks (Start 0h 6-Jan-1980)	
X	Leap_Seconds		Leap time from 0 to 100 s	
X	Braking_Status	Information_Flag	Braking status information 0 to 4,2949673e+9	
X		VXHWithInArmingLimits	Status Flag 0 or 1	
X		AXHWithInArmingLimits	Status Flag 0 or 1	
X		VXHAboveArmingLimit	Status Flag 0 or 1	
X		VXHWithInPostArmingLimits	Status Flag 0 or 1	
X		AXHAboveAbortLimit	Status Flag 0 or 1	
X		VXHWithInStandstillLimits	Status Flag 0 or 1	
X		BrakeCounterResetActivated	Status Flag 0 or 1	
X		BrakePedalActiv	Status Flag 0 or 1	
X		PreArmingConditionsValid	Status Flag 0 or 1	
X		SimpleArmingConditionsValid	Status Flag 0 or 1	
X		ArmingConditionsValid	Status Flag 0 or 1	
X		MeasurementAborted	Status Flag 0 or 1	
X		WindowedStarted	Status Flag 0 or 1	
X		TriggeredStarted	Status Flag 0 or 1	
X		WindowedStopped	Status Flag 0 or 1	
X		Main_TriggeredStopped	Status Flag 0 or 1	
X		VxhZeroCrossingDetected	Status Flag 0 or 1	
X		VelocityThreshold1	Status Flag 0 or 1	
X		VelocityThreshold2	Status Flag 0 or 1	
X		EstimatedQualityThreshold1	Status Flag 0 or 1	
X		MFDDStarted	Status Flag 0 or 1	
X		MFDDStopped	Status Flag 0 or 1	
X		Interm1_WindowedStarted	Status Flag 0 or 1	
X		Interm1_TriggeredStarted	Status Flag 0 or 1	
X		Interm1_WindowedStopped	Status Flag 0 or 1	
X		Braking_State	State of braking (active/inactive) 0 to 255	
X		Abort_Reason	Reason of braking abort 0 to 255	
X		Braking_Counter	Number of brakes stops. If the abort reason of a brake stop is valid, the counter increases with outputting data from 0 to 255	
X		Ext_Trig_Main_Braking	Ext_Trig_Main_Braking_Distance	External triggered braking distance 0 to 4000000 m
X			Ext_Trig_Main_Braking_Time	External triggered braking time 0 to 4000 s
X		Vel_Trig_Main_Window	Windowed_Main_Braking_Distance	Velocity triggered braking distance 0 to 4000000 m (Main Window)

X		Windowed_Main_Braking_Time	Velocity triggered braking time 0 to 4000 s (Main Window)
X	Braking_MFDD	MFDD_Braking_Distance	Velocity triggered braking distance 0 to 4000000 m (MFDD)
X		MFDD_Braking_Time	Velocity triggered braking time 0 to 4000 s (MFDD)
X	Braking_Misc_1	MFDD	Maximum deceleration the vehicle can achieve. 0 to 10 m/s <sup>2</sup>
X		Mean_Deceleration_Windowed	Mean deceleration between main velocity limits 0 to 10 m/s <sup>2</sup>
X		Arming_Velocity_Average	Averaged velocity over x msec before external brake trigger 0 to 100 m/s
X		VXH_at_Ext_Trigger_Start	Velocity at the external braking trigger event 0 to 142 m/s
X	Braking_Misc_2	Normalized_Braking_Distance	Normalized braking distance, calculated by a concept that takes dynamics out of the equation when calculating performance trends 0 to 4000000 m
X		Estimated_Braking_Distance_Error	Estimated error of the distance measurement -30 to 30 m
X		VXH_at_Measurement_Stop	Velocity at measurement stop. 0 to 100 m/s
X	Ext_Trig_Interm_Braking_	Ext_Trig_Interm_Braking_Distance	External triggered intermediate braking distance 0 to 4000000 m
X		Ext_Trig_Interm_Braking_Time	External triggered intermediate braking time 0 to 4000 s
X	Vel_Trig_Interm_Window	Windowed_Interm_Braking_Distance	Velocity triggered braking distance (intermediate window) 0 to 4000000 m
X		Windowed_Interm_Braking_Time	Velocity triggered braking time (intermediate window) 0 to 4000 s

# 6 APPENDIX: LIST OF DECODED OXTS CHANNELS

OxTS NCOM

Channel Packet	Channel Name	Unit	OxTS NCOM Standard	OxTS NCOM Extended
Inertial output	INS_Time_msec	ms	x	x
	Acceleration x	m/s <sup>2</sup>	x	x
	Acceleration y	m/s <sup>2</sup>	x	x
	Acceleration z	m/s <sup>2</sup>	x	x
	Angular rate x	radians/s	x	x
	Angular rate y	radians/s	x	x
	Angular rate z	radians/s	x	x
Position, velocity, orientation	Latitude	degree	x	x
	Longitude	degree	x	x
	Altitude	m	x	x
	North Velocity	m/s	x	x
	East Velocity	m/s	x	x
	Down Velocity	m/s	x	x
	Heading	degree	x	x
	Pitch	degree	x	x
	Roll	degree	x	x
Status, Overall	Navigation status		x	x
	Number of GPS satellites tracked by main GNSS		x	x
	Position mode of main GNSS		x	x
	Velocity mode of main GNSS		x	x
	Orientation mode of dual antenna systems		x	x
	Age of differential corrections from the base-station	s	x	x
	Minutes since GPS begin		x	x
	Number of GPS satellites tracked, primary GNSS		x	x
	Number of satellites used, position		x	x
	Number of satellites used, velocity		x	x
	Number of satellites used, attitude		x	x
Status, position, velocity, orientation accuracies	North position accuracy	m	x	x
	East position accuracy	m	x	x
	Down position accuracy	m	x	x
	Position accuracies age		x	x
	North velocity accuracy	m/s	x	x
	East velocity accuracy	m/s	x	x
	Down velocity accuracy	m/s	x	x
	Velocity accuracies age		x	x
	Heading accuracy	degree	x	x

	Pitch accuracy	degree	x	x
	Roll accuracy	degree	x	x
	Orientation accuracies age		x	x
Status, heading	Heading quality		x	x
	Heading search type		x	x
	Heading search status		x	x
	Heading search ready		x	x
	Heading misalignment angle	degree	x	x
	Accuracy of heading misalignment angle	degree	x	x
Status, antennas	Distance to primary GNSS antenna in x direction	m		x
	Distance to primary GNSS antenna in y direction	m		x
	Distance to primary GNSS antenna in z direction	m		x
	Distance to primary GNSS antenna age			x
	Heading orientation of the GNSS antennas	radians		x
	Pitch orientation of the GNSS antennas	radians		x
	Distance between the GNSS antennas	m		x
	Heading/Pitch/Distance of GNSS antennas age			x
	Accuracy of distance to primary GNSS antenna in x direction	m		x
	Accuracy of distance to primary GNSS antenna in y direction	m		x
	Accuracy of distance to primary GNSS antenna in z direction	m		x
	Accuracy of distance to primary GNSS antenna age			x
	Accuracy of heading orientation of the GNSS antennas	radians		x
	Accuracy of pitch orientation of the GNSS antennas	radians		x
	Accuracy of distance between the GNSS antennas	m		x
	Accuracy heading/pitch/distance between GNSS antennas age			x
Status, receiver details	Number of L1 GPS measurements decoded by primary			x
	Number of L2 GPS measurements decoded by primary			x
	Number of L1 GPS measurements decoded by secondary			x
	Number of L2 GPS measurements decoded by secondary			x
	Number of L1 GLONASS measurements decoded by primary			x
	Number of L2 GLONASS measurements decoded by primary			x
	Number of L1 GLONASS measurements decoded by secondary			x
	Number of L2 GLONASS measurements decoded by secondary			x
	Number of GPS satellites available in heading			x
	Number of GPS satellites used in position			x
	Number of GLONASS satellites used in position			x
	Number of GLONASS satellites available in heading			x
	Number of satellites tracked, primary GNSS			x
Number of satellites tracked, secondary GNSS			x	
Status, local coordinates	Local co-ordinates origin latitude	degree		x
	Local co-ordinates origin longitude	degree		x
	Local co-ordinates origin altitude	m		x
	Local co-ordinates origin heading	degree		x

Status, other	ABD robot UMAC interface status byte			x
	Processing method used by Blended			x
	Gyro bias x	degree/s		x
	Gyro bias y	degree/s		x
	Gyro bias z	degree/s		x
	Gyro bias age			x
	Accelerometer bias x	m/s <sup>2</sup>		x
	Accelerometer bias y	m/s <sup>2</sup>		x
	Accelerometer bias z	m/s <sup>2</sup>		x
	Accelerometer bias age			x
	Gyro scale factor x	ppm		x
	Gyro scale factor y	ppm		x
	Gyro scale factor z	ppm		x
	Gyro scale factor age			x
	Accuracy of gyro bias x	degree/s		x
	Accuracy of gyro bias y	degree/s		x
	Accuracy of gyro bias z	degree/s		x
	Accuracy of gyro bias age			x
	Accuracy of accelerometer bias x	m/s <sup>2</sup>		x
	Accuracy of accelerometer bias y	m/s <sup>2</sup>		x
	Accuracy of accelerometer bias z	m/s <sup>2</sup>		x
	Accuracy of accelerometer bias age			x
	Accuracy of gyro scale factor x	ppm		x
	Accuracy of gyro scale factor y	ppm		x
	Accuracy of gyro scale factor z	ppm		x
	Accuracy of gyro scale factor age			x
	Heading of the vehicle in the INS co-ordinate frame	radians		x
Pitch of the vehicle in the INS co-ordinate frame	radians		x	
Roll of the vehicle in the INS co-ordinate frame	radians		x	

## OxTS RCOM

Channel Packet	Channel Name	Unit	OxTS RCOM Standard
Lane packet	GPS time into minute	ms	x
	Line number to left of A		x
	Line number to right of A		x
	Distance along lane 1	m	x
	Lateral distance to left of A	m	x
	Lateral velocity to left of A	m/s	x
	Lateral acceleration to left of A	m/s <sup>2</sup>	x
	Lateral distance to right of A	m	x
	Lateral velocity to right of A	m/s	x
	Lateral acceleration to right of A	m/s <sup>2</sup>	x

Lateral distance from Point A to Line 1	m	x
Lateral distance from Point A to Line 2	m	x
Lateral distance from Point A to Line 3	m	x
Lateral distance from Point A to Line 4	m	x
Lateral distance from Point A to Line 5	m	x
Lateral distance from Point A to Line 6	m	x
Lateral distance from Point A to Line 7	m	x
Lateral distance from Point A to Line 8	m	x
Line on left of Point B		x
Line on right of Point B		x
Line on left of Point C		x
Line on right of Point C		x
Lateral distance from Point B to line on left of A	m	x
Lateral distance from Point C to line on right of A	m	x
Lateral velocity from Point A to Line 1	m/s	x
Lateral velocity from Point A to Line 2	m/s	x
Lateral velocity from Point A to Line 3	m/s	x
Lateral velocity from Point A to Line 4	m/s	x
Lateral velocity from Point A to Line 5	m/s	x
Lateral velocity from Point A to Line 6	m/s	x
Lateral velocity from Point A to Line 7	m/s	x
Lateral velocity from Point A to Line 8	m/s	x
Lateral distance from Point B to Line 1	m	x
Lateral distance from Point B to Line 2	m	x
Lateral distance from Point B to Line 3	m	x
Lateral distance from Point B to Line 4	m	x
Lateral distance from Point B to Line 5	m	x
Lateral distance from Point B to Line 6	m	x
Lateral distance from Point B to Line 7	m	x
Lateral distance from Point B to Line 8	m	x
Lateral distance from Point C to Line 1	m	x
Lateral distance from Point C to Line 2	m	x
Lateral distance from Point C to Line 3	m	x
Lateral distance from Point C to Line 4	m	x
Lateral distance from Point C to Line 5	m	x
Lateral distance from Point C to Line 6	m	x
Lateral distance from Point C to Line 7	m	x
Lateral distance from Point C to Line 8	m	x
Curvature of Line 1	1/m	x
Curvature of Line 2	1/m	x
Curvature of Line 3	1/m	x
Curvature of Line 4	1/m	x
Curvature of Line 5	1/m	x

	Curvature of Line 6	1/m	x
	Curvature of Line 7	1/m	x
	Curvature of Line 8	1/m	x
	Curvature of Point A	1/m	x
	Curvature of Point B	1/m	x
	Curvature of Point C	1/m	x
	Heading with respect to line on left of A	degree	x
	Heading with respect to line on right of A	degree	x
Extended range packet	Target number		x
	Total number of targets		x
	Lateral range	m	x
	Longitudinal range	m	x
	Lateral range rate	m/s	x
	Longitudinal range rate	m/s	x
	Hunter measurement point position x for this target	m	x
	Hunter measurement point position y for this target	m	x
	Target measurement point position x	m	x
	Target measurement point position y	m	x
	Heading angle of hunter	degree	x
	Heading angle of target	degree	x
	Range status		x
	Forward velocity of hunter	m/s	x
	Lateral velocity of hunter	m/s	x
	Lateral range acceleration	m/s <sup>2</sup>	x
	Longitudinal range acceleration	m/s <sup>2</sup>	x

# 7 LIST OF FIGURES

Figure 1-1: Updating the OXYGEN-license .....	6
Figure 1-2:DAQ-hardware setup - ADMA settings .....	7
Figure 1-3: ADMA enclosures in the Channel List; 6 streams enabled .....	8
Figure 1-4: ADMAnet data output - web interface settings .....	8
Figure 1-5: ADMAdelta data output - web interface settings .....	9
Figure 1-6: ADMA Signal-out settings for PPS-sync with TRION .....	11
Figure 1-7: PPS Sync Settings .....	11
Figure 1-8: Valid PPS-sync signal is received .....	11
Figure 1-9: Software is waiting for a valid PPS signal .....	11
Figure 1-10: Invalid synchronization signal received .....	11
Figure 2-1: Updating the OXYGEN-license .....	12
Figure 2-2:DAQ-hardware setup - RT settings.....	13
Figure 2-3: RT enclosures in the Channel List; 6 streams enabled .....	14
Figure 2-4: OXTS device IP settings .....	15
Figure 2-5: Firewall settings for OXTS.....	15
Figure 2-6: Deactivation of <i>NAVstart_beta</i> .....	15
Figure 2-7: PPS Sync Settings .....	16
Figure 2-8: Valid PPS-sync signal is received .....	16
Figure 2-9: Software is waiting for a valid PPS signal .....	16
Figure 2-10: Invalid synchronization signal received.....	16
Figure 3-1: Updating the OXYGEN-license .....	17
Figure 3-2: Setup tab - Overview .....	18
Figure 3-3: Location tab – Overview .....	19
Figure 3-4: Good (left) and bad examples (middle, right) for selecting GNSS coordinates on the background image .....	20
Figure 3-5: Cursors to assign the GDP coordinates to the background image .....	20
Figure 3-6: Map point menu .....	21
Figure 3-7: Position dialog for one reference point .....	21
Figure 3-8: Position dialog for two reference points.....	22
Figure 3-9: Objects tab - Overview.....	23
Figure 3-10: Vehicles object menu – Overview .....	24
Figure 3-11: IMU channel selection popup menu .....	25
Figure 3-12: Vehicle positioning via X/Y-coordinates .....	25
Figure 3-13: Cones object menu – Overview .....	26
Figure 3-14: IMU channel selection popup menu .....	27
Figure 3-15: Cone positioning via X/Y-coordinates .....	27
Figure 3-16: Cone following another object .....	27
Figure 3-17: Locator object menu – Overview .....	28
Figure 3-18: IMU channel selection popup menu .....	29
Figure 3-19: Locator positioning via X/Y-coordinates .....	29
Figure 3-20: Locator following another object.....	29
Figure 3-21: Locator Quality Channel menu .....	30
Figure 3-22: KML track object menu – Overview .....	30
Figure 3-23: Track line object menu – Overview.....	31
Figure 3-24: Start and End Point definition via X/Y coordinates .....	31
Figure 3-25: Track with radius.....	32
Figure 3-26: DIN 70000 coordinate system definition .....	32
Figure 3-27: SAE coordinate system definition .....	33

Figure 3-28: Objects tab – Overview .....	33
Figure 3-29: Calculation menu for Object 1 .....	34
Figure 3-30: Calculation menu for Object 2 .....	35
Figure 3-31: Calculations in the Channel List topology .....	35
Figure 3-32: Object1 reference coordinate system for calculation.....	36
Figure 3-33: Calculation Example 1 .....	36
Figure 3-34: Calculation Example 2 .....	37
Figure 3-35: Calculation Example 3 .....	38
Figure 3-36: Calculation Example 4 .....	38
Figure 3-37: Calculation Example 5 .....	39
Figure 3-38: Calculation Example 6 .....	39
Figure 3-39: Calculation Example 7 .....	40
Figure 3-40: Calculation Example 8 .....	40
Figure 3-41: Calculation Example 9 .....	41
Figure 3-42: Distance calculations from Car to Track.....	41
Figure 3-43: Calculation Example 10.....	42
Figure 3-44: Calculation Example 11 .....	42
Figure 3-45: Calculation Example 12 .....	43
Figure 3-46: Contour Editor tab – Overview .....	44
Figure 3-47: Contour Editor - <i>Mode- Axis</i> menu .....	45
Figure 3-48: Assignment of the <i>Reference Rectangular</i> to the imported image .....	46
Figure 3-49: Creating the cars' shape.....	47
Figure 3-50: <i>Mode - POIs</i> menu .....	47
Figure 3-51: Contour with added NCAP POIs .....	48
Figure 4-1: BirdsEye instrument – Overview.....	49

## 8 LIST OF TABLES

Table 1-1: DAQ hardware setup - ADMA settings .....	7
Table 2-1: DAQ hardware setup - RT settings .....	13
Table 3-1: Setup tab – Overview .....	18
Table 3-2: Location tab – Overview.....	19
Table 3-3: Objects tab - Overview .....	23
Table 3-4: Vehicles object menu – Overview .....	24
Table 3-5: Cones object menu – Overview .....	26
Table 3-6: Locator object menu – Overview .....	28
Table 3-7: KML track object menu – Overview .....	30
Table 3-8: Track line object menu – Overview .....	31
Table 3-9: Objects tab – Overview .....	34
Table 3-10: Contour Editor menu – Overview.....	44